

BLUE VALLEY SCHOOLS

Blue Valley Unified School District No. 229

Regular Board of Education Meeting

Monday, October 13, 2025, 5:30 PM

Board of Education Room, District Office, 15020 Metcalf Ave., Overland Park, KS 66223

A. OPENING ITEMS.

1. Pledge of Allegiance.

Sosi Girma, a 5th-grade student from Valley Park Elementary, will lead the Pledge of Allegiance.

2. Awards and Recognitions.

Excellence in Education Recipient is Devon Swartz. Devon is a SPED teacher at Liberty View Elementary.

3. Public Comments.

B. REGULAR AGENDA.

1. Call the Meeting to Order.

2. Approval of the Regular Board of Education Meeting Agenda.

MOTION: I move that the Board of Education approve the October 13, 2025, Regular Board of Education meeting agenda as published. This motion, made by Jodie Dietz and seconded by Patrick Hurley, Carried.

Jodie Dietz: Yea

Dr. Sonya Evans: Yea

Patrick Hurley: Yea

Jan Kessinger: Yea

Gina Knapp: Yea

Jim McMullen: Yea

Clay Norkey: Yea

Yea: 7, Nay: 0

C. CONSENT AGENDA.

1. Approval of the Consent Agenda.

Our rules of Parliamentary Procedure provide for a consent agenda listing several items for approval of the Board by a single motion. Documentation concerning these items has been provided to all Board members and the public in advance to ensure an extensive review. Items may be removed from the consent agenda at the request of any board member.

MOTION TO APPROVE: I move that the Board of Education approve the October 13, 2025, Regular Board of Education Meeting consent agenda as published with minor edits deemed necessary by legal counsel. This motion, made by Jodie Dietz and seconded by Gina Knapp, Withdrawn.

I move that the Board of Education approve the October 13, 2025, Regular Board of Education Meeting amended consent agenda as published with minor edits deemed necessary by legal counsel. This motion, made by Patrick Hurley and seconded by Jim McMullen, Carried.

Jodie Dietz: Yea

Dr. Sonya Evans: Yea

Patrick Hurley: Yea

Jan Kessinger: Yea

Gina Knapp: Yea

Jim McMullen: Yea

Clay Norkey: Yea

Yea: 7, Nay: 0

2. Approval of the Meeting Minutes.

3. Approval of the Cash Summary Report.

4. Approval of the Bids and Contracts.

5. Approval of the Human Resources Personnel Report and the Addendum.

6. Approval of the Claims Report and the Disbursement Report.

October 15, 2025., Claims for Payment totaling \$11,907,672.25.

September 2025, Disbursements totaling \$60,743,998.55.

There are no Special Fund Transfers for August 2025.

7. Adoption of the Resolution for Destruction of Records.

This action is taken pursuant to K.S.A. 72-1629.

8. Approval of the Blue Valley Recreation Center Northwest Commissioner Appointment.

The Board of Education recommends appointing Todd Davis as the Blue Valley Recreation Center Northwest Commissioner for a 4-year term commencing October 13, 2025.

9. Approval of the Board Advisory Committee Appointments.

The Board of Education recommends appointing Wendy Connelly to the Community Board Advisory Committee for a one-year term and appointing Scott Wright to the Academic & Activities Board Advisory Committee for a two-year term.

10. Approval of the Termination and Release of Sanitary Sewer Construction and Development Agreement.

11. Approval of the Termination and Release of Street Construction and Development Agreement.

D. REPORTS AND DISCUSSION ITEMS.

1. Board of Education Reports.

09.18.25 Academics & Activities Board Advisory Committee Meeting Minutes

09.22.25 Community Board Advisory Committee Meeting Minutes

10.09.25 Finance & Operations Board Advisory Committee Meeting Minutes

2. Superintendent Report.

3. Strategic Plan Quarterly Update.

4. Design and Construction Report.

5. Policy 6610 Temporary and Personal Illness Leaves Update.

E. ACTION ITEMS.

1. Adoption of the Bond Sale Resolution 2025-AB.

2. Approval of the Human Resources Personnel Report and the Addendum.

Board member Jim McMullen requested that this agenda item be pulled from the consent agenda and be voted on separately by the Board of Education.

I move that the Board of Education approve the HR Report. This motion, made by Jodie Dietz and seconded by Gina Knapp, Carried.

Jodie Dietz: Yea

Dr. Sonya Evans: Yea

Patrick Hurley: Yea

Jan Kessinger: Yea

Gina Knapp: Yea

Jim McMullen: Yea

Clay Norkey: Yea

Yea: 7, Nay: 0

I move that the Board of Education approve the 1st Addendum. This motion, made by Patrick Hurley and seconded by Gina Knapp, Carried.

Jodie Dietz: Yea

Dr. Sonya Evans: Yea

Patrick Hurley: Yea

Jan Kessinger: Yea

Gina Knapp: Yea

Jim McMullen: Yea

Clay Norkey: Yea

Yea: 7, Nay: 0

I move that the Board of Education approve the 2nd Addendum. This motion, made by Gina Knapp and seconded by Jodie Dietz, Carried.

Jodie Dietz: Yea

Dr. Sonya Evans: Yea

Patrick Hurley: Yea

Jan Kessinger: Yea

Gina Knapp: Yea

Jim McMullen: Nay

Clay Norkey: Yea

Yea: 6, Nay: 1

F. CLOSING ITEMS.

1. Board Comments.

2. Adjournment.

BLUE VALLEY SCHOOLS

Blue Valley Unified School District No. 229

Regular Board of Education Meeting

Monday, September 8, 2025, 5:30 PM

Board of Education Room, District Office, 15020 Metcalf Ave., Overland Park, KS 66223

Jodie Dietz: Present
Dr. Sonya Evans: Present
Patrick Hurley: Present
Jan Kessinger: Present
Gina Knapp: Present
Jim McMullen: Present
Clay Norkey: Present

A. OPENING ITEMS.

1. Pledge of Allegiance.

Hanna Ellsworth, a 4th-grade student from Timber Creek Elementary, will lead the Pledge of Allegiance.

2. Conduct the Hearing to Exceed the Revenue Neutral Tax Rate for 2025-26.

The Board President opened the Hearing to Exceed the Revenue Neutral Tax Rate for USD 229 2025-2026 School Year, to the public. Three patrons addressed the Board of Education to express their concerns.

The Board President closed the hearing.

The Board of Education motioned to approve the Resolution to Exceed the Revenue Neutral Tax Rate for the 2025-26 Budget. The Board President conducted a roll-call vote. This motion, made by Jan Kessinger and seconded by Jodie Dietz, Carried.

Jodie Dietz: Yea
Dr. Sonya Evans: Yea
Patrick Hurley: Yea
Jan Kessinger: Yea
Gina Knapp: Yea

Jim McMullen: Nay

Clay Norkey: Yea

Yea: 6, Nay: 1

3. Conduct the Hearing for the Legal Maximum Budget and Estimated Tax Rate for 2025-26.

The Board President opened the hearing for the Legal Maximum Budget and Estimated Tax Rate for 2025-2026 to the public.

No public comments were made.

The Board President closed the Budget Hearing.

4. Awards and Recognitions.

Distinguished Service Award Recipient: Dana Huey is a Para 1 at Timber Creek Elementary.

Excellence in Education Award Recipient: Laura Benschmidt teaches Exploring Health Professions at CAPS.

5. Public Comments.

Three patrons addressed the Board of Education:

1. Amy Thomas had recommendations to change the high school transcript process.
2. Colleen Cunningham expressed concerns about school safety.
3. Senator Kellie Warren spoke about putting a law in place preventing sex offenders from entering schools.

B. REGULAR AGENDA.

1. Call the Meeting to Order.

The Board President called the meeting to order at 6:29 p.m.

2. Approve the Regular Board of Education Meeting Agenda.

I move that the Board of Education approve the September 8, 2025, Regular Board of Education meeting agenda as published. This motion, made by Jodie Dietz and seconded by Patrick Hurley, Carried.

Jodie Dietz: Yea

Dr. Sonya Evans: Yea

Patrick Hurley: Yea

Jan Kessinger: Yea

Gina Knapp: Yea

Jim McMullen: Yea

Clay Norkey: Yea

Yea: 7, Nay: 0

C. CONSENT AGENDA.

1. Approve the Consent Agenda.

Our rules of Parliamentary Procedure provide for a consent agenda listing several items for approval of the Board by a single motion. Documentation concerning these items has been provided to all Board members and the public in advance to ensure an extensive review. Items may be removed from the consent agenda at the request of any board member.

I move that the Board of Education approve the September 8, 2025, Regular Board of Education Meeting consent agenda as published with minor edits deemed necessary by legal counsel. This motion, made by Gina Knapp and seconded by Clay Norkey, Carried.

Jodie Dietz: Yea

Dr. Sonya Evans: Yea

Patrick Hurley: Yea

Jan Kessinger: Yea

Gina Knapp: Yea

Jim McMullen: Yea

Clay Norkey: Yea

Yea: 7, Nay: 0

2. Approve the Meeting Minutes.

The Board of Education approved the minutes of the August 11, 2025, Special Board of Education Meeting and the Regular Board of Education Meeting.

3. Approve the Cash Summary Report.

The Board of Education approved the Cash Summary Report.

4. Approve of Bids and Contracts.

The Board of Education approved the Bids and Contracts.

5. Approve of the Human Resources Personnel Report and the Addendum.

The Board of Education approved the Human Resources Personnel Report and Addendum.

6. Approve the Claims Report and the Disbursement Report.

September 15, 2025, Claims for Payment totaling \$15,575,163.83.

August 2025 Disbursements totaling \$11,919,340.86.

There are no Special Fund Transfers for July 2025.

The Board of Education approved the Claims Report and the Disbursement Report.

7. Appoint Blue Valley Recreation Center Commissioner(s).

Darren Dupriest will serve as the Blue Valley Recreation South Commissioner for a 4-year term commencing October 1, 2025.

The Board of Education appointed Darren Dupriest to serve as the Blue Valley Recreation South Commissioner for a 4-year term commencing October 1, 2025.

8. Appoint the Kansas Association of School Boards Delegate Assembly.

Jodie Dietz as the delegate
Jan Kessinger as the alternate

The Board of Education appointed Jodie Dietz as the delegate and Jan Kessinger as the alternate delegate of the Kansas Association of School Boards Delegate Assembly.

D. REPORTS AND DISCUSSION ITEMS.

1. Board of Education Reports.

2. Superintendent's Report.

Presented by Superintendent Dr. Gillian Chapman.

3. Use of Powered Bicycles & Scooters Update.

Presented by the Executive School Administration team, Shelly Nielsen, Amy Farthing, and Scott Robertson, along with the Director of Safety and Security, Dan Carney.

4. School Safety Update.

Presented by the Director of Safety and Security, Dan Carney.

E. ACTION ITEMS.

1. Approval of the 2025-26 Legal Maximum Budget and Estimated Tax Rate.

Board President Jan Kessinger stated the Building Needs Assessment and State Assessments Review was provided to and evaluated by the USD 229 Board of Education in determining the authority of the local option budget, cost of living, extraordinary growth, special liability, and capital outlay mill levies.

Jan Kessinger left the meeting at 8:10 a.m. and returned at 8:12 a.m.

I move that the Board of Education approve the 2025-26 Legal Maximum Budget and Estimated Tax Rate, including the approval of the local option budget resolution. This motion, made by Patrick Hurley and seconded by Gina Knapp, Unseconded.

Amendment Carried (the Main Motion was Unseconded): I move that the Board of Education approve the 2025-26 Legal Maximum Budget and Estimated Tax Rate, including the approval of a 33% local option budget resolution. This motion, made by Patrick Hurley and seconded by Gina Knapp, Carried.

Jodie Dietz: Yea

Dr. Sonya Evans: Yea

Patrick Hurley: Yea

Jan Kessinger: Yea

Gina Knapp: Yea

Jim McMullen: Nay

Clay Norkey: Yea

Yea: 6, Nay: 1

F. CLOSING ITEMS.

1. Board Comments.

Jodie Dietz: Stated that the Blue Valley Educational Foundation breakfast and the student entertainers were wonderful. She is really excited about the upcoming theater and marching band season.

Jim McMullen: No comments.

Clay Norkey: Thanked the speakers who spoke at the hearing and open forum. He appreciates their comments. He feels it is good to be back at school and visit them again. Attending the football games has been great.

Patrick Hurley: Thanked Dan Carney for answering his hard questions. He told him he is doing a great job. He would like to continue having the conversation about having one officer per school. He understands it is a complicated issue, and we are spending a lot of money. Patrick also thanked Jeremy for answering his hard questions and let him know he also did a great job responding and going back and forth between him and Jim. Patrick stated that it is hard work and difficult to understand, and even harder to explain. He believes tonight's vote was for the right reasons to put us in a position to do what we need to in two years. He thinks we could possibly issue only \$100 million and adjust accordingly, and reduce the mill levy rate. Patrick stated he also agrees with Clay that we need to try and level it out as much as possible so that there's a slight variation from one year to the next. He feels it will be a big challenge adjusting to the school funding. He hopes we can begin preparing scenarios for what that looks like, so we can make sure the impact is reasonable on our end and the impact is negated for our kids. They're the ones who are potentially going to receive the biggest burden here.

Dr. Sonya Evans: Shared how proud she is of our school district and how we care about our children, the parents, the patrons, and our administrators. She feels we have awesome administrators. She appreciates the fact that we live in an outstanding, excellent school district

and that everyone who works in this district truly cares about children. She looks forward to an excellent school year.

Gina Knapp: Reiterated that the Board needs to make advocating for gun safety more of a priority in Topeka. She mentioned how much the district is spending every year and needs relief from all those expenditures. She is happy to approve the budget to pay for them, because she knows we need it, but they need to know how much it is costing us, and it is taking away from our kids. She thinks we need to be advocating from that angle.

2. Adjournment.

The September 8, 2025, Regular Board of Education Meeting adjourned at 8:21 p.m.

Exceeding Revenue Neutral for the 2025-2026 School Year

The governing body of Unified School District 229 will meet on the 8th day of September 2025 at 5:30 PM at 15020 Metcalf Ave, Overland Park, KS 66223 for the purpose of hearing and answering objections of taxpayers relating to the proposed use of all funds and the amount of tax to be levied. Detailed budget information, including budget profile, is available at the USD 229 District Office, on the district website, and will be available at this hearing.

Revenue Neutral

	2024-2025		Revenue Neutral Taxes	Revenue Neutral Tax Rate	2025-2026	
	Actual Taxes Levied	Actual Tax Rate			Proposed Taxes to be Levied	Proposed Tax Rate
General	\$ 84,082,056	20.000	\$ 84,082,056	19.105	\$ 88,019,463	20.000
ALL OTHER FUNDS						
Supplemental General (LOB)	\$ 56,509,220	12.372	\$ 56,509,220	11.899	\$ 61,643,107	12.980
Capital Outlay	36,775,310	8.000	36,775,310	7.698	38,207,531	8.000
Cost of Living	12,057,720	2.639	12,057,720	2.539	12,615,413	2.656
Special Liability Expense Fund	173,730	0.038	173,730	0.037	1,526,161	0.321
Extraordinary Growth Facilities	3,175,684	0.695	3,175,684	0.669	2,504,242	0.527
Bond and Interest #1	44,342,644	9.707	44,342,644	9.337	42,818,161	9.016
Special Assessment	662,497	0.145	662,497	0.139	446,122	0.094

Revenue Neutral Calculation

Total Taxes Levied Including General Fund	\$ 237,778,861	53.596	\$ 237,778,861	51.423	\$ 247,780,200	53.594
Total Taxes Levied Excluding General Fund	\$ 153,696,805	33.596	\$ 153,696,805	32.318	\$ 159,760,737	33.594

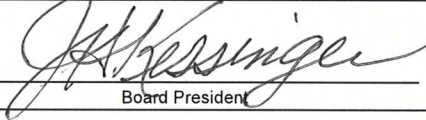
Board President

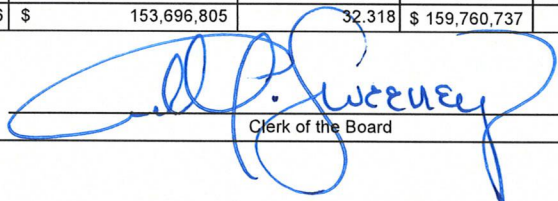
Clerk of the Board



Sample Resolution

K.S.A. 79-2988

For additional information on Revenue Neutral Tax Rate, please download the Revenue Neutral Tax Rate Publication Guidelines located on the School Finance website → Budget Packet (under Resolutions).

The local board of education must approve by resolution to exceed the Revenue Neutral Tax Rate. Below is a sample resolution:

RESOLUTION NO. _____

A resolution expressing the property taxation policy of USD 229 Blue Valley with respect to exceeding the Revenue Neutral Tax Rate for financing the annual budget for 2025-2026.

Whereas, K.S.A 79-2988, provides that a levy of property taxes to finance the 2025-2026 budget of USD 229 exceeds the Revenue Neutral Tax Rate to finance the 2025-2026 budget of USD 229, be authorized by a resolution; and

Whereas, the Board of Education of USD 229 held a hearing on September 8, 2025 allowing all interested taxpayers desiring to be heard an opportunity to give oral testimony; and

Whereas, the Board of Education of USD 229, having heard testimony, still finds it necessary to exceed the Revenue Neutral Rate.

NOW, THEREFORE, BE IT RESOLVED by the Board of Education of USD 229 that the 2025-2026 budget with a levy of property taxes exceeding the Revenue Neutral Tax Rates calculated for 2025-2026, as adjusted pursuant to K.S.A 79-2988 is hereby adopted.

Adopted this 8th day of September, 2025 by USD 229 Blue Valley in Johnson County, Kansas.

Board Clerk Signature

Board President Signature

Board Member Name	Vote	
	Yes	No
1. Jodie Dietz		
2. Dr Sonya Evans		
3. Patrick Hurley		
4. Jan Kessinger		

Board Member Name	Vote	
	Yes	No
5. Gina Knapp		
6. Jim McMullen		
7. Clay Norkey		



AGENDA ITEM SUMMARY

Agenda Item:

Conduct the Hearing to Exceed the Revenue Neutral Tax Rate for 2025-26.

Person Submitting Item:

Jeremy McFadden, CFO

Background and Summary:

In accordance with K.S.A. 79-2988, school districts must conduct a hearing to Exceed Revenue Neutral (RNR) when approving the annual budget. The RNR hearing must be held between August 20 to September 20. School districts are required to publish notices of the RNR hearing a minimum of 10 calendar days between publication and RNR hearing.

Budget Source: N/A

Strategic Plan Alignment:

Advancing Academic Excellence & Exceptional Student Experiences - Budget allocations for effective teacher-to-pupil class ratios, program supports for performing arts, career and technical pathways, supplemental activities and athletic programs, and curriculum resources.

Fostering Supportive & Healthy School Communities - Budget allocations for special education, bilingual, at-risk, counselors and social workers.

Empowering Exemplary Educators and Staff - Budget allocations for competitive, market-aligned compensation packages and job-embedded professional development.

Recommendation:

Approve the Resolution to Exceed the Revenue Neutral Tax Rate for the 2025-26 Budget (roll call vote required).

Notice of Hearing 2025-2026 Budget

The governing body of Unified School District 229 will meet on the 8th day of September 2025 at 5:35 PM at 15020 Metcalf Ave, Overland Park, KS 66223 for the purpose of hearing and answering objections of taxpayers relating to the proposed use of all funds and the amount of tax to be levied. Detailed budget information, including budget profile, building needs assessment and Board state assessments review is available at the USD 229 District Office, on the district website, and will be available at this hearing.

The Amount of 2025 Tax to be Levied and Expenditures (published below) establish the maximum limits of the 2025-2026 Budget. The 'Est. Tax Rate' (column 7), shown for comparative purposes, is subject to slight change depending on final assessed valuation.

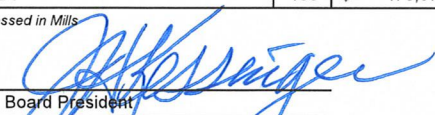
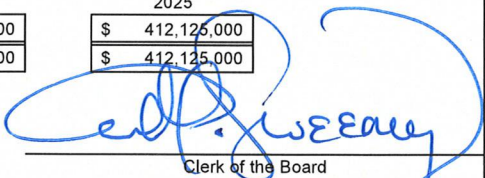
	Code 99 Line	2023-2024 Actual		2024-2025 Actual		2025-2026 Proposed Budget		
		Actual Expenditures (1)	Actual Tax Rate* (2)	Actual Expenditures (3)	Actual Tax Rate* (4)	Budgeted Expenditures (5)	Amount of 2025 Tax to be Levied (6)	Est. Tax Rate* (7)
OPERATING								
General	06	\$ 169,054,909	20.000	\$ 184,124,073	20.000	\$ 193,979,607	\$ 88,019,463	20.000
Supplemental General (LOB)	08	56,213,261	12.190	61,362,859	12.372	64,631,925	61,643,107	12.980
SPECIAL REVENUE								
Federal Funds	07	3,874,309		938,354		1,257,072		
At-Risk Education Fund	13	7,607,931		8,200,406		9,419,374		
Bilingual Education	14	2,541,784		3,193,296		4,551,647		
Virtual Education	15	711,002		756,265		1,272,223		
Capital Outlay	16	37,254,533	7.969	39,937,915	8.000	52,797,080	38,207,531	8.000
Food Service	24	11,751,125		11,345,450		14,900,000		
Professional Development	26	774,318		834,505		1,362,537		
Parent Education Program	28	873,560		878,776		1,218,381		
Summer School	29	153,072		170,899		285,709		
Special Education	30	64,252,831		72,491,921		90,247,154		
Cost of Living	33	11,046,249	2.471	12,457,450	2.639	13,901,978	12,615,413	2.656
Career and Postsecondary Education	34	5,263,643		5,322,266		1,845,000		
Gifts and Grants	35	1,898,883		1,716,064		3,222,188		
Special Liability Expense Fund	42	1,038,722	0.092	1,500,000	0.038	1,325,000	1,526,161	0.321
Extraordinary Growth Facilities	45	4,367,003	0.969	3,312,404	0.695	2,981,164	2,504,242	0.527
Special Reserve Fund	47	31,770,467		34,445,203				
KPERS Special Retirement Contribution	51	24,035,997		24,458,242		30,083,638		
Contingency Reserve	53	-		5,350,000				
Textbook & Student Material Revolving	55	3,822,130		5,018,611				
Activity Fund	56	624,188		418,248				
DEBT SERVICE								
Bond and Interest #1	62	43,144,838	9.973	54,155,738	9.707	57,067,813	42,818,161	9.016
Special Assessment	67	714,439	0.094	709,818	0.145	750,000	446,122	0.094
TOTAL USD EXPENDITURES	100	482,789,194	53.758	533,098,763	53.596	547,099,490	247,780,200	53.594
Less: Transfers	105	119,878,856		130,166,816		90,401,142		
NET USD EXPENDITURES	110	362,910,338		402,931,947		456,698,348		
TOTAL USD TAXES LEVIED	115	227,424,285		237,774,356		247,780,200		
OTHER								
Recreation Commission	84	18,964,833	2.453	20,261,063	2.405	23,189,278	11,636,165	2.450
Rec Comm Emp Benefits & Spec Liab	86	1,567,725	0.499	1,665,080	0.451	2,246,417	1,662,288	0.350
TOTAL OTHER	120	20,532,558	2.952	21,926,143	2.856	25,435,695	13,298,453	2.800
TOTAL TAXES LEVIED	125	\$ 240,120,302		\$ 250,823,941		\$ 261,078,653		
Assessed Valuation - General Fund	128	\$ 4,105,654,845		\$ 4,203,877,545		\$ 4,400,973,133		
Assessed Valuation - All Other Funds	130	\$ 4,298,558,410		\$ 4,567,746,411		\$ 4,749,185,142		
Assessed Valuation - Capital Outlay	129	\$ 4,317,606,543		\$ 4,594,832,843		\$ 4,775,941,393		
Outstanding Indebtedness, July 1		2023		2024		2025		
General Obligation Bonds	135	\$ 475,975,000		\$ 449,455,000		\$ 412,125,000		
TOTAL USD DEBT	155	\$ 475,975,000		\$ 449,455,000		\$ 412,125,000		
<i>*Tax Rates are expressed in Mills</i>								
								
		Board President		Clerk of the Board				

BLUE VALLEY SCHOOLS

Special Board of Education Workshop Meeting Minutes

Monday, August 11, 2025, at 8:00 AM, Board of Education Room,
Blue Valley District Office, 15020 Metcalf Ave. Overland Park, KS 66223

Members present: Jan Kessinger, Clay Norkey, Gina Knapp, Jim McMullan, Dr. Sonya Evans, Jodie Dietz.

Members absent: Patrick Hurley

1. OPENING ITEMS.

A. **Call the Meeting to Order.**

B. **Approve the Special Board of Education Meeting Agenda.**

The Board of Education approved the August 11, 2025, Special Board of Education Meeting agenda, as published.

Moved by: Jim McMullen

Seconded by: Clay Norkey

Carried 5-0



2. REPORTS AND DISCUSSION ITEMS.

A. **Review the Regular Board of Education Meeting Agenda.**

Superintendent Dr. Chapman reviewed the Regular Board of Education Meeting agenda with the Board of Education.

Jodie Dietz arrived at 8:03 a.m.

B. **Review Board Policy 1684 Open Forum.**

- [1684 Open Forum](#) 
- [1684 OPEN FORUM PROPOSED.pdf](#) 

C. **Discuss AP Testing Fees.**

Deputy Superintendent of Learning, Dr. Collier, and Director of Academic Program and Accountability, Adam Wade,

discussed the AP Testing Fees increase with the Board of Education.

D. **Annual Report.**

- [Blue Valley Annual Report.pdf](#) 

Kaci Brutto, Chief Communications Officer, presented the 2024-2025 Annual Report to the Board of Education.

3. **EXECUTIVE SESSION.**

A. **Enter into Executive Session.**

The Board of Education did not enter into an Executive Session.

B. **Return to Open Meeting.**

The Board of Education did not enter into an Executive Session.

4. **CLOSING ITEMS.**

A. **Adjourn.**

The Special Board of Education Workshop Meeting agenda for August 11, 2025, adjourned at 9:06 a.m.

BLUE VALLEY SCHOOLS

Blue Valley Unified School District No. 229

Regular Board of Education Meeting Minutes

Monday, August 11, 2025, at 5:30 PM, Board of Education Room,
Blue Valley District Office, 15020 Metcalf Ave. Overland Park, KS 66223

MEMBERS PRESENT: Jan Kessinger, Clay Norkey, Gina Knapp, Jim McMullan, Dr. Sonya Evans, Jodie Dietz.

A. OPENING ITEMS.

1. **Pledge of Allegiance.**

Officer Tim led the Board of Education in the Pledge of Allegiance.

2. **Public Comments.**

- Steve Roberts - Teacher pay

B. REGULAR AGENDA.

1. **Call the Meeting to Order.**

Board President Jan Kessinger called the meeting to order at 5:37 p.m.

2. **Approve the Regular Board of Education Meeting Agenda.**

The Board of Education motioned to approve the August 11, 2025, Regular Board of Education Meeting agenda as published.

Moved by: Gina Knapp

Seconded by: Jodie Dietz

Carried

C. **CONSENT AGENDA.**

Consent Action

Moved by: Gina Knapp

Seconded by: Clay Norkey

Carried

1. **Approve the Consent Agenda.**

Our rules of Parliamentary Procedure provide for a consent agenda listing several items for approval of the Board by a single motion. Documentation concerning these items has been provided to all Board members and the public in advance to ensure an extensive review. Items may be removed from the consent agenda at the request of any board member.

The Board of Education motioned to approve the August 11, 2025, Regular Board of Education Meeting consent agenda as published with minor edits deemed necessary by legal counsel.

Moved by: Gina Knapp

Seconded by: Clay Norkey

Carried

2. **Approve the Meeting Minutes.**

-

- [07.21.25 Special Board of Education Meeting - WORKSHOP - Minutes - Html](#) 
- [07.21.25 Regular Board of Education Organizational Meeting - Minutes - Html](#) 

3. **Approve the Cash Summary Report.**

-

[Month End Cash Report - June 30, 2025.pdf](#) 

4. **Approve the Claims Report, the Disbursement Report, and the Special Fund Transfers.**

-

- [August 15, 2025, Claims for Payment totaling \\$ 21,466,955.36.](#) 

- [July 2025 Disbursements totaling \\$ 18,643,850.42.](#) 
- [June 2025 Special Fund Transfers totaling \\$ 23,202,951.67](#)  .

5. **Approve the Bids and Contracts.**

-

Bids and contracts may not be available until the day of the Board meeting. All agreements and contracts are subject to the final approval by the Board of Education's attorney.

- [8-7-25 Large Memo.pdf](#) 

6. **Approval of the Human Resources Personnel Report and the Addendum.**



-

The Human Resources Personnel Report and the Addendum may not be available until the day of the board meeting.

- [August 11, 2025 HR Personnel Report.pdf](#) 
- [Addendum August 11, 2025.pdf](#) 

7. **Approve the Science and Social Studies New Curriculum.**

-

- [ES Science Curriculum 2025 \(1\).pdf](#) 
- [ES Social Studies Curriculum 2025 \(1\).pdf](#) 

8. **Approve the Finance and Operations Board Advisory Committee Appointments.**

1. Daniel Mayer - 2-year term
2. Stephanie James - 2-year term
3. Elizabeth Webb - 2-year term
4. Matt Misch - 2-year term

9. **Approve the Community Board Advisory Committee Appointments.**

1. Celia Byers - 2-year term
2. Kristin Gembala - 2-year term
3. Kimberley Kushner - 2-year term
4. Pam Shernuk - 2-year term
5. Abby O'Neill - 2-year term
6. Kelly Selznick - 2-year term

1. Jonathan Freiden - 1-year term
2. Anna Custer-Singh - 1-year term
3. Natalie Svilarich - 1-year term
4. Caroline Chaboo - 1-year term
5. Sarah Cullor - 1-year term
6. Courtney Carlson - 1-year term
7. Jennifer Glanzer - 1-year term
8. Colleen Cunningham - 1-year term
9. Julia Bernard - 1-year term
10. Renee Meares - 1-year term
11. Josh Heizman - 1-year term
12. Kelly Beeck - 1-year term
13. Jennifer Nowak - 1-year term

10. **Approve the Academic & Activities Board Advisory Committee Appointments.**

1. Adrienne Newlin – 2-year term
2. Brittany Verrette – 2-year term
3. Brooke Davids – 2-year term
4. Philon Barr-Manning – 2-year term
5. Sean Burrell – 2-year term
6. Amy Hill – 2-year term
7. Lauren Dreher – 2-year term

1. Brenna Bidwell – 1 year term
2. Kim Grosdidier– 1 year term
3. Ryan Hussey – 1 year term
4. Matt Wachel – 1 year term



11. **Designate the Official District Newspaper for Publication of School Notices for 25-26.**

- The Johnson County Post
- KC Star

12. **Approve the CAPS Board of Directors Appointment.**





- Blue Valley Board Member Jodie Dietz will serve a three-year (3) term on the CAPS Network Board of Directors expiring July 2028.

D. REPORTS AND DISCUSSION ITEMS.

1. **Board of Education Reports.** # - #
The Finance & Operations Board Advisory Committee Meeting Minutes were presented by Jeremy McFadden, CFO.
 - [FO MEETING MINUTES 8 7 2025.pdf](#) 
2. **Superintendent's Report.** # - #
 - [August 2025 Celebrations Update.pdf](#)  was presented by Superintendent Dr. Chapman.

E. ACTION ITEMS.

1. **Approve the 2025-26 Related Service Professionals Negotiated Agreement between the Board of Education and the Blue Valley National Education Association – Related Service Professionals.** # - #
 - **Person Submitting Item:** Dr. Eric Punswick, CHRO
 - **Background and Summary:** The Blue Valley Negotiations Team has reached tentative agreement for the 2025-26 Related Service Professionals Negotiated Agreement. The Blue Valley National Education Association – Related Service Professionals (BVNEA-RSP) bargained for BV Related Service Professionals.
Tentative Agreement Highlights:
 - Step movement for all returning professional employees who were on steps 1-34 in 2024-25
 - 4% increase in each cell of the Professional Employee Salary Schedule
 - Continued district-paid single health insurance premium options.
 - Additions and adjustments to the Supplemental Salary Schedule and Supplemental Positions.
 - Increase temporary leave days from 13 to 14 per contractual year.

- **Budget Source:** General Fund
- **Strategic Plan Alignment:** Empowering Exemplary Educators and Staff
- **Recommendation:** The administration recommends approval of the 2025-26 Related Service Professionals Negotiated Agreement.
- [Final.2025.SupplementalSchedule.pdf](#) 
- [Final.2025_SupChanges.docx - Google Docs.pdf](#) 
- [RSP-Final.2025 Edits.Revisions.docx - Google Docs.pdf](#) 
- [Salary Table.pdf](#) 

The Board of Education motioned to approve the 2025-26 Related Service Professionals Negotiated Agreement.

-

Moved by: Gina Knapp





Seconded by: Jodie Dietz

Carried

2. **Approve the 2025-26 Professional Employee Negotiated Agreement between the Board of Education and the Blue Valley Education Association.**

-

- **Person Submitting Item:** Dr. Eric Punswick, CHRO
- **Background and Summary:** The Blue Valley Negotiations Team has reached tentative agreement for the 2025-26 Professional Employee Negotiated Agreement. The Blue Valley Education Association (BVEA) bargained for BV professional employees. Tentative Agreement Highlights:
 - Step movement for all returning professional employees who were on steps 1-34 in 2024-25
 - 4% increase in each cell of the Professional Employee Salary Schedule

- Continued district-paid single health insurance premium options.
 - Additions and adjustments to the Supplemental Salary Schedule and Supplemental Positions.
 - Increase temporary leave days from 13 to 14 per contractual year.
- **Budget Source:** General Fund
 - **Strategic Plan Alignment:** Empowering Exemplary Educators and Staff
 - **Recommendation:** The administration recommends approval of the 2025-26 Professional Employee Negotiated Agreement.
 - [Final.2025.SupplementalSchedule.pdf](#) 
 - [Final.2025 Edits.Revisions.docx - Google Docs.pdf](#) 
 - [Final.2025 SupChanges.docx - Google Docs.pdf](#) 
 - [Salary Table.pdf](#) 

The Board of Education motioned to approve the 2025-26 Professional Employee Negotiated Agreement.

Moved by: Jodie Dietz

Seconded by: Clay Norkey

Carried

3. **Approve the Classified Compensation for the 2025-26 school year.**

- **Person Submitting Item:** Dr. Eric Punswick, CHRO
- **Background and Summary:** Classified compensation is reviewed, adjusted, and increased on an annual basis based on budgetary considerations. Previously, the Board of Education approved adjustments and increases to all classified wage schedules in August of

2024 for the 2024-25 academic school year. For the 2025-26 academic school year, district administration is recommending a 4% increase to the classified wage schedules.

- **Budget Source:** General Fund
- **Strategic Plan Alignment:** Empowering Exemplary Educators and Staff
- **Recommendation:** The administration recommends approval of an overall increase of 4% to the classified wage schedules for the 2025-26 academic school year.

The Board of Education motioned to approve the overall increase of 4% to the classified wage schedules for the 2025-26 academic school year.

Moved by: Jim McMullen

Seconded by: Clay Norkey

Carried

4. **Approve the Administrator Compensation for the 2025-26 school year.**

- **Person Submitting Item:** Dr. Eric Punswick, CHRO
- **Background and Summary:** Administrator compensation is reviewed, adjusted, and increased on an annual basis based on budgetary considerations. Previously, the Board of Education approved adjustments and increases to all administrator wages in August of 2024 for the 2024-25 academic school year. For the 2025-26 academic school year, district administration is recommending a 4% overall increase for administrators.
- **Budget Source:** General Fund

- **Strategic Plan Alignment:** Empowering Exemplary Educators and Staff
- **Recommendation:** The administration recommends approval of an overall increase of 4% for administrators for the 2025-26 academic school year.

The Board of Education motioned to approve the overall increase of 4% for administrators for the 2025-26 academic school year.

Moved by: Jim McMullen

Seconded by: Jodie Dietz



Carried

5. **Approve the Publication to Exceed the Revenue Neutral Tax Rate for the 2025-26 Budget.**

- **Person Submitting Item:** Jeremy McFadden, CFO
- **Background and Summary:** In accordance with K.S.A. 79-2988, school districts must conduct a hearing to Exceed Revenue Neutral (RNR) when approving the annual budget. The RNR hearing must be held between August 20 to September 20. School districts are required to publish notices of the RNR hearing a minimum of 10 calendar days between publication and RNR hearing.
- **Budget Source:** N/A
- **Strategic Plan Alignment:**
 1. Advancing Academic Excellence & Exceptional Student Experiences – Budget allocations for effective teacher-to-pupil class ratios, program supports for performing arts, career and technical pathways, supplemental activities and athletic programs, and curriculum resources.

2. Fostering Supportive & Healthy School Communities – Budget allocations for special education, bilingual, at-risk, counselors and social workers.
3. Empowering Exemplary Educators and Staff – Budget allocations for competitive, market-aligned compensation packages and job-embedded professional development.

- **Recommendation:** Approve the Publication of Exceeding Revenue Neutral for the 2025-26 School Year.

- [Exceeding Revenue Neutral 2025-26 School Year.pdf](#) 
- [Notice of RNR Hearings - Taxpayer Statement.pdf](#) 
- [House Bill No. 2125 - Pg 5.pdf](#) 

The Board of Education motioned to approve the Publication of Exceeding Revenue Neutral for the 2025-26 School Year.

Moved by: Gina Knapp

Seconded by: Patrick Hurley



Carried

6. **Approve the Publication for the Notice of Hearing 2025-26 Budget.**

- **Person Submitting Item:** Jeremy McFadden, CFO
- **Background and Summary:** School districts must conduct an annual budget hearing prior to approving the maximum limits of the budget, the amount of tax to be levied, and an estimated tax rate. The approved budget and tax levy is due by September 20 to KSDE and by October 1 to Johnson County. School districts are required to publish notice of the budget hearing a minimum of 10 calendar days between publication and budget hearing.
- **Budget Source:** N/A

- **Strategic Plan Alignment:**
 1. Advancing Academic Excellence & Exceptional Student Experiences – Budget allocations for effective teacher-to-pupil class ratios, program supports for performing arts, career and technical pathways, supplemental activities and athletic programs, and curriculum resources.
 2. Fostering Supportive & Healthy School Communities – Budget allocations for special education, bilingual, at-risk, counselors and social workers.
 3. Empowering Exemplary Educators and Staff – Budget allocations for competitive, market-aligned compensation packages and job-embedded professional development.

- **Recommendation:** Approve Publication for Notice of Hearing 2025-26 Budget.

- [F150--2026.pdf](#) 
- [Notice of Hearing 2025-26 Budget.pdf](#) 
- [Outstanding Debt Service - USD 229 \(as of 6.30.25\).pdf](#)



The Board of Education motioned to approve the Publication for Notice of Hearing for the 2025-26 Budget.

Moved by: Patrick Hurley

Seconded by: Gina Knapp

Carried

F. CLOSING ITEMS.

1. Adjournment.

- Dr. Sonya Evans thanked our finance department and administrators for a fantastic job. She mentions she feels uncomfortable with the fact that we only have one month of reserves.

- Jodie Dietz welcomed back teachers, our staff, and students, and families.
- Clay Norkey thanked Principal Phoebe Lewis from Pleasant Ridge Middle School for inviting him to talk to staff members to pump them up as we begin the school year. He also thanked our Communications Team for the Rally in the Valley planning and pivoting after losing power in the afternoon. He felt Dr. Chapman did an excellent job at the Leawood Chamber of Commerce. He loved Sister Steele's comments after 25 years that if we do not address the social emotional issues that kids go through, we're never going to get through them, and they cannot learn. . He applauded the HR team, Carrie Myers and the BVEA team for their collaborative and transparent negotiations, and encouraged everyone to get their legislators to fully fund Special Education.
- Jan Kessinger echoed those thoughts. He felt the chamber breakfast was great. And thought Dr. Chapman really did such a great job, having been on the job just a few weeks. He said it made him proud that our board made that hire. It really reflected well on our district. He could really see the enthusiasm of the teachers at Rally in the Valley and the Onboarding event, and it's going to be a great year.

The August 11, 2025, Regular Board of Education meeting adjourned at 6:44 p.m.

Board Clerk

Anna M. Sweeney

Board President

Jan Kessinger

USD 229 Blue Valley Schools

Cash Summary

Fund #	Description	July 31, 2023	July 31, 2024	July 31, 2025
006	General	\$ 11,076,230	\$ 4,164,649	\$ 5,767,875
008	Supplemental General	3,476,884	3,631,404	735,567
013	At Risk	4,684,871	2,906,168	1,560,526
014	Bilingual	1,099,056	1,429,328	3,496,836
015	Virtual Education	642,394	675,107	360,164
016	Capital Outlay	5,331,552	5,488,844	3,912,510
024	Food Service	5,515,470	4,425,785	3,145,254
026	Professional Development	969,158	1,769,241	984,234
028	Parents As Teachers	481,867	693,664	394,237
029	Summer School	183,696	127,618	80,564
030	Special Education	8,026,770	5,709,306	5,229,255
033	Cost of Living	128,069	192,071	-
034	Career & Postsec Educ	829,527	1,957,351	5,200,447
042	Special Liability	346,619	733,171	(619,162)
045	Extraordinary Growth	256,543	143,151	50,727
047	Special Reserve W/C	2,025,671	3,080,545	2,299,518
048	Special Reserve Healthcare	16,609,254	16,955,270	18,111,906
051	KPERS	-	-	-
053	Contingency Reserve	20,000,000	20,250,000	14,900,000
055	Textbook & Student Materials	3,200,397	4,489,554	1,842,096
056	District Activity	373,343	(24,887)	54,760
062	Bond & Interest	62,079,818	67,103,311	61,776,848
067	Special Assessment	868,272	619,036	594,182
084	BVRC General	-	-	-
086	BVRC Empl Benefits	-	-	-
125	Title I	(73,081)	(179)	(62)
127	Title II-A	(55,125)	(1,499)	1
131	Title III	(11,145)	(2,367)	0
134	Other Federal Funds	(3,512,593)	(779,290)	-
135	Title VIB CEIS	-	-	-
201	Gift	778,184	817,862	706,838
202	DAC	25,582	3,784	18,905
203	BV Educational Foundation	327,747	373,622	394,827
204	SAFE School Grants	326,425	321,487	-
205	Misc Community Grants	81,951	71,256	71,202
211	Kauffman CAPS Networking	139,855	55,820	(275)
212	Mental Health Intervention Grant	-	-	1,381
300	College Now	-	-	-
		\$ 146,233,261	\$ 147,380,182	\$ 131,071,163

811	Bond-Capital Projects 2020	\$ 7,824,630	\$ 5,699,559	\$ -
812	Bond-Capital Projects 2023	154,106,297	94,759,936	(39,949,952)
		\$ 161,930,926	\$ 100,459,496	\$ (39,949,952)

TOTALS

\$ 308,164,187 \$ 247,839,677 \$ 91,121,211

Purchasing Memo

To: Finance & Operations Committee Members
From: Jason Gillam, Director of Business Operations
Jake Slobodnik, Executive Director of Operations
Date: September 4, 2025
Re: Purchases

PURCHASES \$500,000 & ABOVE

25020 Medical Benefits RFP **\$41,230,521.00 Estimated**
Vendor: Blue Cross and Blue Shield of Kansas City
Location: District Wide
Anticipated Funds: Special Reserve Healthcare
Page 6

BIDS

Emergency Purchase – Gym Floor repair at Blue Valley High gym **\$33,210.00 Estimated**
Vendor: Lankford Enterprises Inc
Location: BVH
Anticipated Funds: Capital Outlay
Page 93

E-Rate FCC Form 470 Number 240015170 Network Switches **\$192,250.00**
Vendor: CDW Government Inc
Location: District Wide
Anticipated Funding: Bond
Page 95

26008 Grass Seed **\$90,972.80 Estimated**
Vendor: Grass Pad, Inc.
Location: Grounds Department
Anticipated Funds: Capital Outlay
Page 108

26009 Grounds Trailer **\$28,850.00**
Vendor: Hoyt's Trailer Center
Location: Grounds Department
Anticipated Funds: Capital Outlay
Page 110

26010 Fertilizer **\$20,387.20 Estimated**
Vendors: Grass Pad \$8,075.20
Reinders \$12,312.00
Location: Grounds Department
Anticipated Funds: Capital Outlay
Page 112

26011 Utility Cab Tractor **\$53,600.00**
Vendor: Coleman Equipment, Inc.
Location: Grounds Department
Anticipated Funds: Capital Outlay
Page 114

26012 Transit Vans **\$207,549.00**
Vendor: Shawnee Mission Ford Inc
Location: Facilities & Operations
Anticipated Funds: Capital Outlay
Page 116

26013 Engineering Supplies **\$32,466.80**
Vendor: Project Lead the Way Inc
Location: Blue Valley West High School
Anticipated Funds: Capital Outlay
Page 118

26014 3D Printers **\$27,752.55**
Vendor: Staples, Inc.
Location: High Schools
Anticipated Funds: Capital Outlay
Page 120

COOPERATIVE PURCHASES

4J Facility Supply LLC **\$35,000.00 Estimated**
Purchase of yearly gym floor maintenance coat for the east half of the District.
Cooperative: TIPS #230103
Anticipated Funds: Capital Outlay
Page 122

American Digital Security LLC **\$28,643.49 Estimated**
Purchase to add cameras to the exterior of the Hilltop Learning Center building.
Cooperative: TIPS #240101
Anticipated Funds: Bond
Page 125

Brady Industries of Kansas LLC **\$44,429.50**
Purchase of 10 new Kaivac machines for restroom cleaning.
Cooperative: Greenbush #24.7 ESC-Facility Solutions2024
Anticipated Funds: Capital Outlay
Page 129

CDW Government Inc **\$83,080.00**
This purchase of network equipment will support the paging replacement project in elementary schools. 26-013
Cooperative: Greenbush #022-G
Anticipated Funds: Bond
Page 131

Goodwin Pro Turf Inc **\$450,000.00 Estimated**
Landscaping and Athletic Field Services
Cooperative: Greenbush # 25.4 ESC-lawngroundsmaint2025
Anticipated Funds: Capital Outlay
Page 134

Hillyard Kansas City **\$35,000.00 Estimated**
Purchase of yearly gym floor maintenance coat for the west half of the District.
Cooperative: TIPS #230103
Anticipated Funds: Capital Outlay
Page 135

Hon Company

\$32,899.20

Purchase of chairs for District office staff.
Cooperative: Omnia Partners #R240117
Anticipated Funds: Bond
Page 138

Wenger Corporation

\$21,799.33

Purchase of handicap ramp for stages used at all facilities.
Cooperative: Omnia Partners #R240120
Anticipated Funds: Capital Outlay
Page 143

SERVICE PURCHASES

Accruent LLC

2024/2025

2025/2026 – 2028/2029

N/A

\$100,253.50 Estimated

This purchase is to move EMS software from a local server supported license to a cloud license to allow for access to EMS across all computer platforms across the district. We have currently paid \$24,450.44 for our EMS enterprise, District maintenance and EMS room sign term licenses that will be credited against the three-year commitment of \$100,253.50. Our net incremental cost over the three-year commitment, if we factor in expected increases in the current platform at the rate we have seen each year over the last three-year renewals, is \$19,322.55. After migration all district platforms, MAC and PC will have access to EMS systems, maintenance will reside at Accruent (it is currently on site with periodic Accruent visits), and Microsoft TEAMS and EMS room sign licenses will synchronize.

Year 1: \$32,870.00
Year 2: \$32,870.00
Year 3: \$34,513.50
Total: \$100,253.50

Funds: General Fund
Page 146

Behavioral Health Allies

2024/2025

2025/2026

N/A

\$207,120.00 Estimated

Student (AT) will be transported to Behavioral Health Allies Academy from their home, and student (AM) will be transported from Behavioral Health Allies to KVC Academy.

Funds: SPED
Page 153

Behavioral Health Allies

2024/2025

2025/2026

N/A

\$97,000.00 Estimated

Student (AT) will attend private school at Behavioral Health Allies Academy based on an IEP decision.

Funds: SPED
Page 154

The Brighthouse Academy LLC

2024/2025

2025/2026

N/A

\$99,000.00 Estimated

Student (BF) will attend Brighthouse Academy for the 25-26 school year. This is an IEP decision.

Funds: SPED
Page 155

City of Overland Park

2024/2025

2025/2026

N/A

\$0.00

This agreement is between Blue Valley School District and the City of Overland Park to dedicate a temporary construction easement to the City. This easement is required for the new middle school project.

Funds: N/A
Page 160

City of Overland Park	<u>2024/2025</u>	<u>2025/2026</u>
	N/A	\$0.00
This agreement is between Blue Valley School District and the City of Overland Park to dedicate a private water service line easement to the water utility company, WaterOne. This easement is related to the expansion of the Blue Valley Recreation Activity Center.		
Funds: N/A		
Page 167		
Fix a Field LLC	<u>2024/2025</u>	<u>2025/2026</u>
	N/A	\$40,000.00 Estimated
Playground/Athletic Field Turf Repairs and Cleaning - District wide.		
Playground (account 23990) \$20,000.00		
Athletic Fields (account 23901) \$20,000.00		
Funds: Capital Outlay		
Page 174		
Interpreting Solutions LLC	<u>2024/2025</u>	<u>2025/2026</u>
	N/A	\$80,000.00 Estimated
Contracted Level 4 ASL interpreting services for student GM at BVM.		
Funds: SPED		
Page 175		
Johnson County Community College	<u>2024/2025</u>	<u>2025/2026</u>
	\$310,088.68	\$450,000.00
This is an extension of the MOU for our Career Ready Partnership with Johnson County Community College. This partnership allows high school juniors and seniors to attend courses at JCCC.		
Funds: Career & Technical Education		
Page 176		
Maxim Healthcare Services Inc	<u>2024/2025</u>	<u>2025/2026</u>
	N/A	\$72,000.00 Estimated
This is for an LPN to provide nursing services for student (AW) at ACCESS.		
Funds: SPED		
Page 177		
Maxim Healthcare Services Inc	<u>2024/2025</u>	<u>2025/2026</u>
	N/A	\$76,000.00 Estimated
A nurse (RN) is needed to provide services for a student (BB) at BVN.		
Funds: SPED		
Page 178		
Niles Home for Children	<u>2024/2025</u>	<u>2025/2026</u>
	N/A	\$44,100.00 Estimated
Student (AM) attending KVC Academy for the 25-26 school year per IEP decision.		
Funds: SPED		
Page 179		
ProCare Therapy	<u>2024/2025</u>	<u>2025/2026</u>
	N/A	\$40,000.00 Estimated
Para staffing support to fill a vacancy at BVM for the 25-26 school year.		
Funds: SPED		
Page 185		
ProCare Therapy	<u>2024/2025</u>	<u>2025/2026</u>
	N/A	\$40,000.00 Estimated
Para to fill a vacancy at BRE for the 25-26 school year.		
Funds: SPED		
Page 187		

ProCare Therapy 2024/2025
N/A 2025/2026
\$40,000.00 Estimated

Para to fill a vacancy at OTM for the 25-26 school year.
Funds: SPED
Page 189

ProCare Therapy 2024/2025
N/A 2025/2026
\$40,000.00 Estimated

A para floater to fill a vacancy for the 2025-26 school year.
Funds: SPED
Page 191

SoftwareIDM Inc 2024/2025
\$45,000.00 2025/2026
\$45,000.00

Microsoft Active Directory Enterprise license Subscription. The software takes accounts from Synergy and BPlus and creates them in Office 365, Google, Active Directory, etc.
Funds: Capital Outlay
Page 193

Southwest Airlines Co / Varsity Spirit 2024/2025
N/A 2025/2026
\$56,625.00 Estimated

Nationals Dance Competition Trip February 2/12-2/17/2026 in Orlando, FL. Additional expenses include \$3,500 for ground transportation. Fundraising efforts and individual family contributions will pay for this trip.
Air Travel – Southwest Airlines \$24,125
Registration/Lodging – Varsity Spirit \$32,500
Funds: Activity Funds
Page 197

Southwest Airlines Co / Means Transportation / Walt Disney World / FAME 2024/2025
N/A 2025/2026
\$133,281.95 Estimated

BVHS choir travel for show choir competition and performance at Walt Disney World. Total Travel cost anticipated at \$133,581.95. Families will be responsible for the cost of their students. If fundraising can be done, the cost will be lowered. School personnel travel cost will be wrapped into each of the 75 students' cost. This is NOT a required trip. Optional only.

Southwest Airlines	\$34,000.00
Means Transportation	\$12,750.00
Walt Disney World (lodging)	\$35,429.70
Walt Disney World (park tickets)	\$39,852.25
FAME (show choir competition host)	\$11,250.00

Funds: Activity Funds
Page 198

Supplemental Healthcare Services 2024/2025
N/A 2025/2026
\$36,000.00 Estimated

SLP services to cover for maternity leave at WSE (.4 FTE).
Funds: SPED
Page 203

Validity Screening Solutions 2024/2025
\$39,783.50 Est. 2025/2026
\$38,000.00 Estimated

Validity Screening Solutions provides background screening services for the District. The District is renewing services for the 25-26 fiscal year.
Funds: Capital Outlay
Page 205

RESCIND

KL Harper Holdings LLC 2024/2025
N/A 2025/2026
\$48,000.00 Estimated

Originally reported in July 2025. Staff member fell through.
Funds: SPED



AGENDA ITEM SUMMARY

Agenda Item:

Renewal for Group Medical Plan for 2026 awarded to Blue Cross Blue Shield of Kansas as the result of an RFP process.

Person Submitting Item:

Eric Punswick

Background and Summary:

Medical rates were negotiated from 15.8% increase to 14.9% increase. Final increase after plan design changes and reserve utilization is 10.09% increase for 2026.

Budget Source:

Estimated total cost \$41,230,521.00 from special reserve healthcare fund 048-8914.

Strategic Plan Alignment:

The renewal of quality medical plans supports the strategic priority of empowering exemplary educators and staff. Strong benefits attract and retain exceptional educators; this results in greater student success. Promoting the wellbeing of employees honors the value of each staff member and engages BV, as an employer, who fosters supportive and healthy school communities.

Recommendation:

Approve the renewal of the Blue Cross Blue Shield of Kansas City Medical Plan for 2026.



PURCHASING UNIVERSAL REQUEST

BLUE VALLEY SCHOOL DISTRICT #229

Department/Bldg.:	Human Resources	Requested By:	Dr. Eric Punswick
Purpose: (please explain in detail why we need the items or services requested)			
<p>The Group Medical Plan for 2026 is awarded to Blue Cross Blue Shield of Kansas City as the result of an RFP process. Rates were negotiated from 15.8% increase to 14.9% increase. Final increase after plan design changes and reserve utilization is 10.09% increase for 2026. The estimated total cost is \$41,230,521.00</p>			
Fund:	Special Reserve Healthcare	Account Number:	048-8914
Funding Year:	2025/2026	Location(s) items or services are for:	District Wide Benefits
Does this use Bond Funds? (if yes, see below)		No	
<input type="checkbox"/> This request includes extended warranty, service or maintenance. Please complete the <u>Bond Warranty Agreement Form on page 2</u>		<input type="checkbox"/> This request includes training or consultation. Please complete <u>Bond Consultant Services Form on Page 3</u>	

Check all that apply to this Purchase:

- | | |
|--|--|
| <input type="checkbox"/> This is a New Contract | <input type="checkbox"/> This is a New Bid/RFP |
| <input checked="" type="checkbox"/> This is a Renewal Contract | <input checked="" type="checkbox"/> This is a Purchase from Bid/RFP # <u>25020</u> |
| <input type="checkbox"/> This is a Curriculum purchase | <input type="checkbox"/> This Purchase requires BOE Signatures |
| <input type="checkbox"/> This can be purchased off of _____ Contract # _____ | |

Begin Date: 1/1/2026	End Date: 12/31/2026
Company: Blue Cross and Blue Shield of KC	Street Address: 1400 Baltimore Ave
Contact Name: Kimberly Walker	City: Kansas City
Telephone: (816) 360-1051	State: MO
Email: kim.walker@bluekc.com	Zip Code: 64105
Cost: \$ 41,230,521.00 Estimated	
Prior Year Cost: \$ 37,450,724.00 Estimated	
Terms: (Annual, Multi-Year, One-Time): Annual	

Month:(board meeting) September 2025 **Budget Administrator** Dr. Eric Punswick **Date** 8/25/2025



Kansas City

Unified School District No. 229, Johnson County, State of Kansas
14274000

Blue Connect Rate Confirmation
Contract Effective Date: January 1, 2026

PPO Blue Select Plus Plan	Blue Connect
Employee	\$2.00 PEPM
Employee/Spouse	\$2.00 PEPM
Employee/Child(ren)	\$2.00 PEPM
Family	\$2.00 PEPM

PPO Preferred Care Blue Plan	Blue Connect
Employee	\$2.00 PEPM
Employee/Spouse	\$2.00 PEPM
Employee/Child(ren)	\$2.00 PEPM
Family	\$2.00 PEPM

BlueSelect Plus - EPO Plan	Blue Connect
Employee	\$2.00 PEPM
Employee/Spouse	\$2.00 PEPM
Employee/Child(ren)	\$2.00 PEPM
Family	\$2.00 PEPM

Preferred-Care Blue - BlueSaver Plan	Blue Connect
Employee	\$2.00 PEPM
Employee/Spouse	\$2.00 PEPM
Employee/Child(ren)	\$2.00 PEPM
Family	\$2.00 PEPM

BlueSelect Plus - SPIRA EPO Plan	Blue Connect
Employee	\$2.00 PEPM
Employee/Spouse	\$2.00 PEPM
Employee/Child(ren)	\$2.00 PEPM
Family	\$2.00 PEPM

BlueSelect Plus - SPIRA BlueSaver	Blue Connect
Employee	\$2.00 PEPM
Employee/Spouse	\$2.00 PEPM
Employee/Child(ren)	\$2.00 PEPM
Family	\$2.00 PEPM

Signature

Title

Date

Signature

Title

Date

Signature

Title

Date

Signature

Title

Date

Signature

Title

Date

Signature

Title

Date

Performance Standards Agreement

BlueConnect Group

Unified School District No. 229,
Johnson County, State of Kansas



Kansas City

Administrative Performance Measures

Claims Processing

Claims Administrative Accuracy

Administrative accuracy shall be determined by reviewing a statistically valid sample of medical/dental claims for the correctness of coding accuracy in the administration of the plan. Examples of administrative errors include correct amounts sent to the wrong payee, and/or misapplied deductibles and maximums that do not result in payment errors. Administrative accuracy errors do not include any claims that affect claims payment or deductible accumulation, nor any errors that are corrected by Company prior to audit.

Administrative accuracy will be determined by counting the number of claims in a monthly sample that contains one or more coding errors (errors that do not affect claim payment) divided by the total number of claims in the sample. The resulting number shall then be subtracted from 1.00 to determine the administrative accuracy rate.

Performance Standards

97% and greater accuracy: No Penalty
92% to 96.9% accuracy: \$16,000 Penalty
Accuracy less than 92%: \$32,000 Penalty

Claims Financial Accuracy

Financial accuracy shall be determined by reviewing a statistically valid sample of medical and dental claims for the dollar amount of payment errors. Payment errors for financial accuracy shall be defined as claims payments that are either overpayments or underpayments of the amounts due to plan participants (i.e. payment in the wrong amount, duplicate payments, payment for non-eligible benefits, misapplied deductible or maximums resulting in payment errors). A financial error that is corrected by Company prior to audit shall not be considered as being a payment error. Overpayments and underpayments made on the same claim to the same provider that result in a correct net payment being made to such provider on such claim shall not be considered a financial payment error.

Financial accuracy of claims payments will be based on the dollar value of the payment errors measured as a percentage of total paid claims (dollar value of payment errors divided by the total dollars paid). The resulting number shall then be subtracted from 1.00 to determine the financial accuracy rate.

Performance Standards

99% and greater accuracy: No Penalty
98.9% to 92% accuracy: \$16,000 Penalty
Accuracy less than 92%: \$32,000 Penalty

Claims Processing Timeliness

Claims processing timeliness shall be determined by reviewing claims systems reports for the length of time incurred in processing clean medical claims. Clean medical and dental claims are defined as claims that do not require investigation or intervention. Claims requiring investigation include all claims that are not yet processed and are being held until Company is provided with all information pertinent to the claims as requested by Company and as necessary for processing of the claim. Claims requiring intervention include but are not limited to COB claims, claims requiring medical review, etc. Claims requiring investigation or intervention will not be considered for claims processing timeliness.

Claims processing time will be determined by measuring the interval of business days between the date the clean claim is received by Company and the date the claim is finalized by Company.

Performance Standards

95% or more within 14 days: No Penalty
90% to 94.9% within 14 days: \$16,000 Penalty
Less than 90% within 14 days: \$32,000 Penalty

Performance Standards Agreement

BlueConnect Group

Unified School District No. 229,
Johnson County, State of Kansas



Kansas City

Administrative Performance Standards – General Principles

The Administrative Performance Guarantees penalty amounts apply to fees (excluding Optional, Non-Standard Services, and or network savings fees) as outlined in the Contract between Administrator and the Plan Sponsor and will be adjusted in accordance with the performance standards set forth below.

The performance measures will be effective January 1, 2026 and will remain in force through December 31, 2026 (hereinafter the "Measurement Period"), or until termination of the Contract between the two parties, whichever is sooner. Administrator will place a maximum of \$96,000 of medical fees at risk. For each category, performance will be measured by, and penalties, if any, will be calculated on the basis of Administrators audits, surveys, or reports as described in this document. Plan Sponsor retains the right to have internal or external auditors verify the accuracy of Administrators reported results at the Plan Sponsor's expenses.

1. Measurement of Administrator performance against the standards shall be performed and reported to Plan Sponsor by Administrator on a quarterly basis or as otherwise noted.
2. The measures discussed herein are average measures relative to the entire Measurement Period, as set out above. The Appropriate penalties will be paid if the result fails to meet the established goal for the entire Measurement Period. Select measures will be reported on a quarterly basis for illustrative purposes only. The final report for the measurement period will be delivered to Group once data on all performance measures is available and calculated by Administrator. Payment will be credited to Group's account, if coverage is renewed for the following plan year. In the event Group terminates coverage before penalties are paid, Administrator is not liable to remit payment for the Measurement Period.
3. This performance guarantee agreement applies only in regard to Plan Sponsor's health services provided directly by Administrator. It is not intended to apply to any other service of coverage, including but not limited to dental and/or life insurance coverage, and carve-outs such as vision, prescription drug card and mental health.

Payment of Penalties

Although Administrator will provide quarterly performance reports, penalties will be assessed for any plan year in which Administrator fails to meet or exceed the performance standards specified herein for Claims Processing and Network Discounts. Performance will be calculated based on an annual average, excluding the best and worst months.

Audit of Performance

Plan Sponsor agrees to accept the results and the methodology, as defined therein under Administrator's internal quality assurance review process, as the measurement of the criteria set forth in this agreement.

*Remainder of page intentionally Left blank
Performance Agreement continues on the following page*

Performance Standards Agreement

BlueConnect Group
Unified School District No. 229,
Johnson County, State of Kansas



Except stated herein, this agreement shall not be construed to otherwise change any of the terms or conditions of the Master Contract.

Approved and agreed to this _____ day of _____, 2025.

**Unified School District No. 229
Johnson County, State of Kansas
(Plan Sponsor)**

**Blue Cross and Blue Shield
of Kansas City
(Administrator)**

By: _____
President, Board of Education

By: _____

Title: _____

Date: _____

Date: _____

Attested by:

*Clerk, Board of Education
Approved as to Form:*

Attorney, Board of Education



Kansas City

Confirmation of Coverage	
Group Name:	Unified School District No. 229, Johnson County, State of Kansas
Offer Name:	Renewal
Group Number:	14274000
State:	Kansas
Effective Date:	01/01/2026
Important Notes:	RX Rewards being added at no cost to group
Offer-Related Information	
A. General Information	
Contract Term:	12 Months
Subsequent Renewal Terms:	12 Months
Renewal Notification:	180 Days
Annual Enrollment Period Start:	83 Days prior to Group Anniversary Date
Annual Enrollment Period End:	59 Days after Group Anniversary Date
Waiting Period:	Group Assigns
Eligibility Rule:	Group Assigns
Termination Rule:	Group Assigns
Leave of Absence Term:	Not applicable
Dependent Limiting Age:	26 Years
Dependent Limiting Age Termination:	EOY following birthday
Is Employer subject to ERISA?:	No
Are Section 125 Enrollment Changes Allowed?:	Yes
Dedicated Customer Service:	No
Blue Connect Contact Number (local):	816-395-2244
Blue Connect Contact Number (toll free):	1-888-890-4661
HSA Bank Selection:	UMB HSA Eligibility File Feed sent - No
Reinstatement Fee:	\$500
B. Medical Programs and Services	
AHY (subscribers/spouse with medical):	AHY Platinum (1000+)
AHY Standard Buyup (employees with no medical):	No
Wellness Stipend:	\$0
Healthy Companion:	Yes
Virtual Care:	Yes
Livongo Program:	Yes
Avalon:	Yes
APEA:	Yes
Rx Savings Solution:	Yes
Rx Rewards Incentive Program	Yes

Rx Carve-in Credits:	Yes \$55.00 - PMPM
C. Blue KC Vision Coverage	
Blue Vue Base:	No
Blue Vue 10/100:	No
Blue Vue 10/130:	No
Blue Vue 10/150:	No
Blue Vue 10/200:	No
Blue Vue 0/130:	No
Blue Vue 0/150:	No
Blue Vue 0/200:	No
Blue Vue Non-Standard:	No
D. USAble Coverage	
Term Life:	No
AD&D:	No
E. Principal Coverage	
Group Term Life:	No
Voluntary Life:	No
Long Term Disability (LTD):	No
Short Term Disability (STD):	No
Critical Illness:	No
Accident:	No
Dental:	No
Vision:	No

Offer Summary and Signatures
Plans included in this Offer:
For details about the plans included in this offer, please see the attached Plan information.
PPO Blue Select Plus Plan (CG2V)
PPO Preferred Care Blue Plan (CG2Q)
BlueSelect Plus - EPO Plan (CG2S)
Preferred-Care Blue - BlueSaver Plan (CG2R)
BlueSelect Plus - SPIRA EPO Plan (CG2T)
BlueSelect Plus - SPIRA BlueSaver - PPO Plan (CG7F)

Confirmed by: Unified School District No. 229,
Johnson County, State of Kansas

Accepted by Blue Cross and
Blue Shield of Kansas City:

Signature

Signature

Title

Title

Date

Date

Attested by:

Clerk, Board of Education
Approved as to Form:

Attorney, Board of Education

This page intentionally left blank



Kansas City

Plan Information	
Group Name:	Unified School District No. 229, Johnson County, State of Kansas
Plan Name:	PPO Blue Select Plus Plan
Group Number:	14274000
State:	Kansas
Effective Date:	01/01/2026
Important Notes:	
For Internal Use Only:	Package: 2343580828 XREF: CG2V Medical: 2344150579 Rx: 2344490661
1. General Plan Information	
Benefit Period	Calendar Year
Funding	Cost Plus
Grandfathered Status	Non-Grandfathered
Product Family	PPO
Consumer-Driven Health Plan (CDHP)	N/A
Spira Care Plan?	No
Religious Employer?	N/A
Classification of Eligible Employees	In accordance with group HR policy
Eligibility	
Minimum Participation Rate	Not Applicable
Enrollment Change Threshold	Not Applicable
Minimum Employee Only Contribution	Not Applicable
Minimum Overall Contribution	Not Applicable
COBRA Billing	Employer
Are Domestic Partners Covered?	No
Are Spouses Covered?	Yes
Are Same Sex Spouses Covered?	Yes
Insurance Coverage Creditable (Medicare Part D)	Yes
Clinical Solutions	
Oncology Utilization Management	Yes
Oncology Care Management	Yes
Musculoskeletal (MSK) Utilization Management	Yes
Cardiac Utilization Management	Yes
Blue Connect	Blue Connect Tier Level : Advanced Support Blue Connect PEPM Rate \$2 Connect PEPM Rate \$2 Active Employees? : Yes Retirees Eligible? : Yes COBRA Employees Eligible? : Yes
Smart Shopper	Smart Shopper Included
2. Network	

Local Medical Network	BlueSelect Plus Services rendered at Out-of-Network providers are subject to Out-of-Network allowables as stated in your contract, and balance billing may occur.	
Out-of-Area Medical Network	BlueCard PPO/EPO	
Total Care	Total Care is a national program comprised of locally tailored Blue Cross and Blue Shield value-based programs, including Patient-Centered Medical Homes, Accountable Care Organization or similar programs designed to demonstrate results in improving patients' health while managing costs. Members in some plans will have a lower copay if they receive care from a provider in the Total Care program.	
Pharmacy	See Pharmacy (Sections 5 & 6)	
3. Cost Sharing		
Medical Deductible - Calendar Year, Embedded All INN & OON Cross Accum	In-Network	Out-of-Network
Individual	\$1,500	\$1,500
Family	\$4,000	\$4,000
Pharmacy Deductible	Separate Deductible (see Pharmacy Section)	
Medical Coinsurance	In-Network	Out-of-Network
Member Pays	20%	50%
Plan Pays	80%	50%
Out-of-Pocket Limit - Calendar Year, Embedded All INN & OON Cross Accum The Out-of-Pocket limit includes all Deductibles, Coinsurance, and Copayments a member pays during the Benefit Period.	In-Network	Out-of-Network
Individual	\$7,500	\$15,000
Family	\$18,750	\$36,750
Pharmacy Out-of-Pocket Limit	Combined with Medical	
Annual First Dollar Coverage	Does not apply	Does not apply
Annual Maximum	Does not apply	Does not apply
Lifetime Maximum	Does not apply	Does not apply
4. Benefits		
Professional Services	In-Network	Out-of-Network
Primary Care Physician Office Visit - An internist, family practitioner, general practitioner, or pediatrician.	\$40 Copay/Visit, no Deductible	50% Coinsurance after Deductible
Total Care Primary Care Physician Office Visit	\$20 Copay/Visit, no Deductible	Not applicable
Specialist Physician Office Visit - Doctors of Medicine (MD), Doctors of Osteopathy (DO), except Primary Care Physicians, and other medical practitioners such as optometrists, psychologists and chiropractors.	\$80 Copay/Visit, no Deductible	50% Coinsurance after Deductible
Urgent Care Office Visit	\$80 Copay/Visit, no Deductible	50% Coinsurance after Deductible
Total Care Urgent Care Office Visit	Does not apply	Not applicable
Blue KC Virtual Care - Office Visit Virtual care provided by Blue KC virtual care partner(s).	\$80 Copay/Visit, no Deductible	Not applicable
Blue KC Virtual Care - Behavioral Health Therapy Virtual care provided by Blue KC virtual care partner(s).	20% Coinsurance after Deductible	Not applicable
	\$40 Copay/Visit, no Deductible	50% Coinsurance after Deductible

Telehealth - Telehealth Providers other than Blue KC Virtual Care - Office Visit - Primary Care		
Telehealth - Telehealth Providers other than Blue KC Virtual Care - Office Visit - Behavioral Health	\$20 Copay/Visit, no Deductible	50% Coinsurance after Deductible
Telehealth - Telehealth Providers other than Blue KC Virtual Care - Behavioral Health Therapy	20% Coinsurance after Deductible	50% Coinsurance after Deductible
Designated Health Clinic	Does not apply	Not applicable
Other Benefits (in alphabetical order)	In-Network	Out-of-Network
ABA Services	Subject to Applicable Cost Shares	Subject to Applicable Cost Shares
Abortion	Not covered	Not covered
Acupuncture	Not covered	Not covered
Allergy Testing	20% Coinsurance after Deductible	50% Coinsurance after Deductible
Allergy Treatment	20% Coinsurance after Deductible	50% Coinsurance after Deductible
Ambulance - Air	20% Coinsurance after Deductible	20% Coinsurance after In-Network Deductible
Ambulance - Ground Ground Ambulance Allowable Option: 150% of Medicare	20% Coinsurance after Deductible	20% Coinsurance after In-Network Deductible
Assisted Reproductive Services	Not covered	Not covered
Autism-Related Services No Limits	Subject to Applicable Cost Shares	Subject to Applicable Cost Shares
Bariatric Services	Not covered	Not covered
Blue Distinction Specialty Care Facility Services No Limits	Not Applicable	Not Applicable
Chiropractic Office Visit	\$80 Copay/Visit, no Deductible	50% Coinsurance after Deductible
Dental Anesthesia Maximum age limit of 5 Years	Missouri/Kansas Default	Missouri/Kansas Default
Diabetic Equipment and Supplies Prior Authorization Policy Applies	20% Coinsurance after Deductible	50% Coinsurance after Deductible
Diabetic Footwear	20% Coinsurance after Deductible	50% Coinsurance after Deductible
Diabetic Pump	Covered as Durable Medical Equipment (DME)	Covered as Durable Medical Equipment (DME)
Diabetic Self Management Education/Training (DSMT)	No member cost share	50% Coinsurance after Deductible
Durable Medical Equipment (DME) Prior Authorization Policy Applies No Limits	20% Coinsurance after Deductible	50% Coinsurance after Deductible
Elective Male Sterilization	No member cost share	50% Coinsurance after Deductible
Emergency Services Copay Waiver Rule: Copay Waived if Admitted	\$250 Copay/Visit, then Deductible, then 20% Coinsurance	\$250 Copay/Visit, then In-Network Deductible, then 20% Coinsurance
Food and Food Products for PKU Maximum benefit of \$5,000/Calendar Year for In-Network and Out-of-Network	Covered	Covered
Foot Orthotics	Not covered	Not covered
Gender Dysphoria-Related Services Prior Authorization Policy Applies Gender Dysphoria Cost Shares Apply to Cosmetic Services: No Gender Dysphoria Cost Shares Apply to Non-Surgical Services: Yes	Subject to Applicable Cost Shares	Subject to Applicable Cost Shares

Gender Dysphoria Cost Shares Apply to Reassignment Surgery: Yes		
Hearing Aids	Not covered	Not covered
High Tech Radiology (MRI, MRA, PET, CT) Prior Authorization Policy Applies	20% Coinsurance after Deductible	50% Coinsurance after Deductible
Home Health Care Prior Authorization Policy Applies Maximum benefit of 60 Visit(s)/Calendar Year for In-Network and Out-of-Network	20% Coinsurance after Deductible	50% Coinsurance after Deductible
Home Hospice	20% Coinsurance after Deductible	50% Coinsurance after Deductible
Immunizations - Not Routine Preventive	Not covered	Not covered
Infertility and Impotency Diagnosis & Treatment Infertility and impotency treatment: No limits Medical Dollar limitations include pharmacy: Yes	20% Coinsurance after Deductible	50% Coinsurance after Deductible
Inpatient Hospice Prior Authorization Policy Applies Maximum benefit of 14 Day(s)/Lifetime for In-Network and Out-of-Network	20% Coinsurance after Deductible	50% Coinsurance after Deductible
Inpatient Hospital Facility (including Physician Services billed by Facility) Prior Authorization Policy Applies	20% Coinsurance after Deductible	50% Coinsurance after Deductible
Inpatient Physician Services	20% Coinsurance after Deductible	50% Coinsurance after Deductible
Labs Performed in Office / Independent Lab	No member cost share	50% Coinsurance after Deductible
Maternity Dependent Daughters Maternity Covered?: No	Covered	Covered
Mental Health and Substance Abuse Services - Inpatient Hospital Facility (including Physician Services billed by Facility) Prior Authorization Policy Applies	20% Coinsurance after Deductible	50% Coinsurance after Deductible
Mental Health and Substance Abuse Services - Inpatient Physician Services	20% Coinsurance after Deductible	50% Coinsurance after Deductible
Mental Health and Substance Abuse Services - Office Visit	\$20 Copay/Visit, no Deductible	50% Coinsurance after Deductible
Mental Health and Substance Abuse Services - Outpatient Therapy in a Facility	20% Coinsurance after Deductible	50% Coinsurance after Deductible
Mental Health and Substance Abuse Services - Outpatient Therapy in a Provider's Office	20% Coinsurance after Deductible	50% Coinsurance after Deductible
Nutritional Counseling No Limits Nutritional Counseling Services Covered: Includes all Dx	Subject to Applicable Cost Shares	Subject to Applicable Cost Shares
Organ Transplant Services Prior Authorization Policy Applies	Subject to Applicable Cost Shares Blue Distinction Specialty Care Facility Services: Not applicable	Subject to Applicable Cost Shares
Organ Transplant Travel Expenses	Not covered	Not covered
Other Services Performed in Office	20% Coinsurance after Deductible	50% Coinsurance after Deductible

Outpatient Physician Services	20% Coinsurance after Deductible	50% Coinsurance after Deductible
Outpatient Surgery Prior Authorization Policy Applies	20% Coinsurance after Deductible	50% Coinsurance after Deductible
Outpatient Therapy - Cardiac Therapy No Limits	20% Coinsurance after Deductible	50% Coinsurance after Deductible
Outpatient Therapy - Cognitive Therapy	20% Coinsurance after Deductible	50% Coinsurance after Deductible
Outpatient Therapy - Hearing Therapy in a Facility Combined with Hearing Therapy in a Provider's Office Limits	20% Coinsurance after Deductible	50% Coinsurance after Deductible
Outpatient Therapy - Hearing Therapy in a Provider's Office Combined with Speech Therapy Limits	20% Coinsurance after Deductible	50% Coinsurance after Deductible
Outpatient Therapy - Occupational Therapy in a Facility Combined with Occupational Therapy in a Provider's Office Limits	20% Coinsurance after Deductible	50% Coinsurance after Deductible
Outpatient Therapy - Occupational Therapy in a Provider's Office Combined with Physical Therapy Limits	20% Coinsurance after Deductible	50% Coinsurance after Deductible
Outpatient Therapy - Physical Therapy in a Facility Combined with Physical Therapy in a Provider's Office Limits	20% Coinsurance after Deductible	50% Coinsurance after Deductible
Outpatient Therapy - Physical Therapy in a Provider's Office Maximum benefit of 60 Visit(s)/Calendar Year for In-Network and Out-of-Network	20% Coinsurance after Deductible	50% Coinsurance after Deductible
Outpatient Therapy - Pulmonary Therapy No Limits	20% Coinsurance after Deductible	50% Coinsurance after Deductible
Outpatient Therapy - Skeletal Manipulation Prior Authorization Policy Applies Out-of-Network Combined with Physical Therapy Limits	20% Coinsurance after Deductible	50% Coinsurance after Deductible
Outpatient Therapy - Speech Therapy in a Facility Combined with Speech Therapy in a Provider's Office Limits	20% Coinsurance after Deductible	50% Coinsurance after Deductible
Outpatient Therapy - Speech Therapy in a Provider's Office Maximum benefit of 20 Visit(s)/Calendar Year for In-Network and Out-of-Network	20% Coinsurance after Deductible	50% Coinsurance after Deductible
Private Duty Nursing Combined with Home Health Care Limits	20% Coinsurance after Deductible	50% Coinsurance after Deductible
Routine Preventive Care Diabetes Prevention Program (DPP): Covered Preventive Schedule: PPACA+ (Women's Preventive)	No member cost share	50% Coinsurance after Deductible
Skilled Nursing Facility (SNF) Prior Authorization Policy Applies Maximum benefit of 30 Day(s)/Calendar Year for In-Network and Out-of-Network	20% Coinsurance after Deductible	50% Coinsurance after Deductible
Sports Physicals by a Physician	Not covered	Not covered
Vision Exam-Routine	Not covered	Not covered

Vision Hardware	Not covered	Not covered
Weight Management - Wondr Health	No member cost share	Not Applicable
Wigs	Not covered	Not covered
X-Rays and Radiology INN X-Rays and Radiology Included in Office Visit Copay: No	20% Coinsurance after Deductible	50% Coinsurance after Deductible
5. General Pharmacy Information		
Pharmacy Network(s)	Network 1: RxPremier	
Prescription Drug List Learn more about the drugs covered by your plan, drug category/tier, prior authorization and step therapy by reviewing your prescription drug list on MyBlueKC.com	Premium Formulary	
Outpatient Prescription Drug Deductible You must pay all the costs up to the Deductible amount before this plan begins to pay for covered services. All INN & OON Cross Accum	In-Network Individual :\$200 Family: \$400	Out-of-Network Individual :\$200 Family: \$400
Outpatient Prescription Drug Out-of-Pocket Limits The Out-of-Pocket Limit is the most you could pay during the Calendar Year for your share of the cost of covered services.	In-Network Combined with Medical Out-of-Pocket	Out-of-Network Combined with Medical Out-of-Pocket
Infertility/Impotency Drugs	No limit Combined Medical/Pharmacy limit	
Biosimilar Product Penalty	Applies	
Maintenance Medication Program	Not applicable	
Generics Program	Generics Preferred DAW Rules	
Copay Credit Accumulator Adjustment (CCAA): Specialty drug copay card dollars will not be included in your deductible and/or out-of-pocket limits. Only your true out-of-pocket costs will be applied to your deductible and/or out-of-pocket totals.	Yes	
Variable Copay Solution (VCS): When you use a drug copay card, Specialty prescription drugs may be subject to a new plan benefit cost share. This new cost share will not impact you or the price you pay.	Yes	
Rx Savings Solutions A team of pharmacists and pharmacy technician will help you make sure you're getting the best possible pricing for your medicines. Member support is available Monday – Friday, 7 a.m. to 7 p.m. CST.	Register online at MyBlueKC.com and stay up-to-date on cost saving opportunities. Email: info@rxsavingsllc.com PH: 1-800-268-4476	
6. Plan Benefits – Pharmacy		
	In-Network	Out-of-Network

Retail Pharmacy (Short-term supply: Up to 34 Days) Drug Tier 1: Generic / Generic Specialty	RxPremier: Deductible, then \$12 Copay/Fill	Deductible, then \$12 Copay/Fill, then 50% Coinsurance
Drug Tier 2: Preferred / Preferred Specialty	RxPremier: Deductible, then \$60 Copay/Fill	Deductible, then \$60 Copay/Fill, then 50% Coinsurance
Drug Tier 3: Non-Preferred / Non-Preferred Specialty	RxPremier: Deductible, then \$80 Copay/Fill	Deductible, then \$80 Copay/Fill, then 50% Coinsurance
Retail Pharmacy (Long-term supply: Between 35-102 Days) Drug Tier 1: Generic / Generic Specialty	RxPremier: Deductible, then \$30 Copay/Fill	Deductible, then \$30 Copay/Fill, then 50% Coinsurance
Drug Tier 2: Preferred / Preferred Specialty	RxPremier: Deductible, then \$150 Copay/Fill	Deductible, then \$150 Copay/Fill, then 50% Coinsurance
Drug Tier 3: Non-Preferred / Non-Preferred Specialty	RxPremier: Deductible, then \$200 Copay/Fill	Deductible, then \$200 Copay/Fill, then 50% Coinsurance
Mail Order Pharmacy (Mail Order supply: Between 35-102 Days) Drug Tier 1: Generic	Deductible, then \$24 Copay/Fill	Deductible, then \$24 Copay/Fill, then 50% Coinsurance
Drug Tier 2: Preferred	Deductible, then \$120 Copay/Fill	Deductible, then \$120 Copay/Fill, then 50% Coinsurance
Drug Tier 3: Non-Preferred	Deductible, then \$160 Copay/Fill	Deductible, then \$160 Copay/Fill, then 50% Coinsurance
Infertility Drugs Retail (Short-term supply) Drug Tier 1: Generic / Generic Specialty	RxPremier: Deductible, then \$12 Copay/Fill, then 50% Coinsurance	Deductible, then \$12 Copay/Fill, then 50% Coinsurance
Drug Tier 2: Preferred / Preferred Specialty	RxPremier: Deductible, then \$60 Copay/Fill, then 50% Coinsurance	Deductible, then \$60 Copay/Fill, then 50% Coinsurance
Drug Tier 3: Non-Preferred / Non-Preferred Specialty	RxPremier: Deductible, then \$80 Copay/Fill, then 50% Coinsurance	Deductible, then \$80 Copay/Fill, then 50% Coinsurance
Infertility Drugs Retail (Long-term supply) Drug Tier 1: Generic / Generic Specialty	RxPremier: Deductible, then \$30 Copay/Fill, then 50% Coinsurance	Deductible, then \$30 Copay/Fill, then 50% Coinsurance
Drug Tier 2: Preferred / Preferred Specialty	RxPremier: Deductible, then \$150 Copay/Fill, then 50% Coinsurance	Deductible, then \$150 Copay/Fill, then 50% Coinsurance
Drug Tier 3: Non-Preferred / Non-Preferred Specialty	RxPremier: Deductible, then \$200 Copay/Fill, then 50% Coinsurance	Deductible, then \$200 Copay/Fill, then 50% Coinsurance
Infertility Drugs Mail Order Pharmacy Drug Tier 1: Generic / Generic Specialty	Deductible, then \$24 Copay/Fill, then 50% Coinsurance	Deductible, then \$24 Copay/Fill, then 50% Coinsurance
Drug Tier 2: Preferred / Preferred Specialty	Deductible, then \$120 Copay/Fill, then 50% Coinsurance	Deductible, then \$120 Copay/Fill, then 50% Coinsurance
Drug Tier 3: Non-Preferred / Non-Preferred Specialty	Deductible, then \$160 Copay/Fill, then 50% Coinsurance	Deductible, then \$160 Copay/Fill, then 50% Coinsurance
Impotency Drugs Retail (Short-term supply) Drug Tier 1: Generic / Generic Specialty	RxPremier: Deductible, then \$12 Copay/Fill, then 50% Coinsurance	Deductible, then \$12 Copay/Fill, then 50% Coinsurance

Drug Tier 2: Preferred / Preferred Specialty	RxPremier: Deductible, then \$60 Copay/Fill, then 50% Coinsurance	Deductible, then \$60 Copay/Fill, then 50% Coinsurance
Drug Tier 3: Non-Preferred / Non-Preferred Specialty	RxPremier: Deductible, then \$80 Copay/Fill, then 50% Coinsurance	Deductible, then \$80 Copay/Fill, then 50% Coinsurance
Impotency Drugs Retail (Long-term supply) Drug Tier 1: Generic / Generic Specialty	RxPremier: Deductible, then \$30 Copay/Fill, then 50% Coinsurance	Deductible, then \$30 Copay/Fill, then 50% Coinsurance
Drug Tier 2: Preferred / Preferred Specialty	RxPremier: Deductible, then \$150 Copay/Fill, then 50% Coinsurance	Deductible, then \$150 Copay/Fill, then 50% Coinsurance
Drug Tier 3: Non-Preferred / Non-Preferred Specialty	RxPremier: Deductible, then \$200 Copay/Fill, then 50% Coinsurance	Deductible, then \$200 Copay/Fill, then 50% Coinsurance
Impotency Drugs Mail Order Pharmacy Drug Tier 1: Generic / Generic Specialty	Deductible, then \$24 Copay/Fill, then 50% Coinsurance	Deductible, then \$24 Copay/Fill, then 50% Coinsurance
Drug Tier 2: Preferred / Preferred Specialty	Deductible, then \$120 Copay/Fill, then 50% Coinsurance	Deductible, then \$120 Copay/Fill, then 50% Coinsurance
Drug Tier 3: Non-Preferred / Non-Preferred Specialty	Deductible, then \$160 Copay/Fill, then 50% Coinsurance	Deductible, then \$160 Copay/Fill, then 50% Coinsurance
Weight Loss Drugs	Not covered	Not covered
Abortion Drugs	Not covered	Not covered

This page intentionally left blank



Kansas City

Plan Information	
Group Name:	Unified School District No. 229, Johnson County, State of Kansas
Plan Name:	PPO Preferred Care Blue Plan
Group Number:	14274000
State:	Kansas
Effective Date:	01/01/2026
Important Notes:	
For Internal Use Only:	Package: 2343400576 XREF: CG2Q Medical: 2344430957 Rx: 2344340409
1. General Plan Information	
Benefit Period	Calendar Year
Funding	Cost Plus
Grandfathered Status	Non-Grandfathered
Product Family	PPO
Consumer-Driven Health Plan (CDHP)	N/A
Spira Care Plan?	No
Religious Employer?	N/A
Classification of Eligible Employees	In accordance with group HR policy
Eligibility	
Minimum Participation Rate	Not Applicable
Enrollment Change Threshold	Not Applicable
Minimum Employee Only Contribution	Not Applicable
Minimum Overall Contribution	Not Applicable
COBRA Billing	Employer
Are Domestic Partners Covered?	No
Are Spouses Covered?	Yes
Are Same Sex Spouses Covered?	Yes
Insurance Coverage Creditable (Medicare Part D)	Yes
Clinical Solutions	
Oncology Utilization Management	Yes
Oncology Care Management	Yes
Musculoskeletal (MSK) Utilization Management	Yes
Cardiac Utilization Management	Yes
Blue Connect	Blue Connect Tier Level : Advanced Support Blue Connect PEPM Rate \$2 Connect PEPM Rate \$2 Active Employees? : Yes Retirees Eligible? : Yes COBRA Employees Eligible? : Yes
Smart Shopper	Smart Shopper Included
2. Network	

Local Medical Network	Preferred-Care Blue Services rendered at Out-of-Network providers are subject to Out-of-Network allowables as stated in your contract, and balance billing may occur.	
Out-of-Area Medical Network	BlueCard PPO/EPO	
Total Care	Total Care is a national program comprised of locally tailored Blue Cross and Blue Shield value-based programs, including Patient-Centered Medical Homes, Accountable Care Organization or similar programs designed to demonstrate results in improving patients' health while managing costs. Members in some plans will have a lower copay if they receive care from a provider in the Total Care program.	
Pharmacy	See Pharmacy (Sections 5 & 6)	
3. Cost Sharing		
Medical Deductible - Calendar Year, Embedded All INN & OON Cross Accum	In-Network	Out-of-Network
Individual	\$1,500	\$1,500
Family	\$4,000	\$4,000
Pharmacy Deductible	Separate Deductible (see Pharmacy Section)	
Medical Coinsurance	In-Network	Out-of-Network
Member Pays	20%	40%
Plan Pays	80%	60%
Out-of-Pocket Limit - Calendar Year, Embedded All INN & OON Cross Accum The Out-of-Pocket limit includes all Deductibles, Coinsurance, and Copayments a member pays during the Benefit Period.	In-Network	Out-of-Network
Individual	\$7,500	\$15,000
Family	\$18,750	\$36,750
Pharmacy Out-of-Pocket Limit	Combined with Medical	
Annual First Dollar Coverage	Does not apply	Does not apply
Annual Maximum	Does not apply	Does not apply
Lifetime Maximum	Does not apply	Does not apply
4. Benefits		
Professional Services	In-Network	Out-of-Network
Primary Care Physician Office Visit - An internist, family practitioner, general practitioner, or pediatrician.	\$40 Copay/Visit, no Deductible	40% Coinsurance after Deductible
Total Care Primary Care Physician Office Visit	\$20 Copay/Visit, no Deductible	Not applicable
Specialist Physician Office Visit - Doctors of Medicine (MD), Doctors of Osteopathy (DO), except Primary Care Physicians, and other medical practitioners such as optometrists, psychologists and chiropractors.	\$80 Copay/Visit, no Deductible	40% Coinsurance after Deductible
Urgent Care Office Visit	\$80 Copay/Visit, no Deductible	40% Coinsurance after Deductible
Total Care Urgent Care Office Visit	Does not apply	Not applicable
Blue KC Virtual Care - Office Visit Virtual care provided by Blue KC virtual care partner(s).	\$80 Copay/Visit, no Deductible	Not applicable
Blue KC Virtual Care - Behavioral Health Therapy Virtual care provided by Blue KC virtual care partner(s).	20% Coinsurance after Deductible	Not applicable
	\$40 Copay/Visit, no Deductible	40% Coinsurance after Deductible

Telehealth - Telehealth Providers other than Blue KC Virtual Care - Office Visit - Primary Care		
Telehealth - Telehealth Providers other than Blue KC Virtual Care - Office Visit - Behavioral Health	\$20 Copay/Visit, no Deductible	40% Coinsurance after Deductible
Telehealth - Telehealth Providers other than Blue KC Virtual Care - Behavioral Health Therapy	20% Coinsurance after Deductible	40% Coinsurance after Deductible
Designated Health Clinic	Does not apply	Not applicable
Other Benefits (in alphabetical order)	In-Network	Out-of-Network
ABA Services	Subject to Applicable Cost Shares	Subject to Applicable Cost Shares
Abortion	Not covered	Not covered
Acupuncture	Not covered	Not covered
Allergy Testing	20% Coinsurance after Deductible	40% Coinsurance after Deductible
Allergy Treatment	20% Coinsurance after Deductible	40% Coinsurance after Deductible
Ambulance - Air	20% Coinsurance after Deductible	20% Coinsurance after In-Network Deductible
Ambulance - Ground Ground Ambulance Allowable Option: 150% of Medicare	20% Coinsurance after Deductible	20% Coinsurance after In-Network Deductible
Assisted Reproductive Services	Not covered	Not covered
Autism-Related Services No Limits	Subject to Applicable Cost Shares	Subject to Applicable Cost Shares
Bariatric Services	Not covered	Not covered
Blue Distinction Specialty Care Facility Services No Limits	Not Applicable	Not Applicable
Chiropractic Office Visit	\$80 Copay/Visit, no Deductible	40% Coinsurance after Deductible
Dental Anesthesia Maximum age limit of 5 Years	Missouri/Kansas Default	Missouri/Kansas Default
Diabetic Equipment and Supplies Prior Authorization Policy Applies	20% Coinsurance after Deductible	40% Coinsurance after Deductible
Diabetic Footwear	20% Coinsurance after Deductible	40% Coinsurance after Deductible
Diabetic Pump	Covered as Durable Medical Equipment (DME)	Covered as Durable Medical Equipment (DME)
Diabetic Self Management Education/Training (DSMT)	No member cost share	40% Coinsurance after Deductible
Durable Medical Equipment (DME) Prior Authorization Policy Applies No Limits	20% Coinsurance after Deductible	40% Coinsurance after Deductible
Elective Male Sterilization	No member cost share	40% Coinsurance after Deductible
Emergency Services Copay Waiver Rule: Copay Waived if Admitted	\$250 Copay/Visit, then Deductible, then 20% Coinsurance	\$250 Copay/Visit, then In-Network Deductible, then 20% Coinsurance
Food and Food Products for PKU Maximum benefit of \$5,000/Calendar Year for In-Network and Out-of-Network	Covered	Covered
Foot Orthotics	Not covered	Not covered
Gender Dysphoria-Related Services Prior Authorization Policy Applies Gender Dysphoria Cost Shares Apply to Cosmetic Services: No Gender Dysphoria Cost Shares Apply to Non-Surgical Services: Yes	Subject to Applicable Cost Shares	Subject to Applicable Cost Shares

Gender Dysphoria Cost Shares Apply to Reassignment Surgery: Yes		
Hearing Aids	Not covered	Not covered
High Tech Radiology (MRI, MRA, PET, CT) Prior Authorization Policy Applies	20% Coinsurance after Deductible	40% Coinsurance after Deductible
Home Health Care Prior Authorization Policy Applies Maximum benefit of 60 Visit(s)/Calendar Year for In-Network and Out-of-Network	20% Coinsurance after Deductible	40% Coinsurance after Deductible
Home Hospice	20% Coinsurance after Deductible	40% Coinsurance after Deductible
Immunizations - Not Routine Preventive	Not covered	Not covered
Infertility and Impotency Diagnosis & Treatment Infertility and impotency treatment: No limits Medical Dollar limitations include pharmacy: Yes	20% Coinsurance after Deductible	40% Coinsurance after Deductible
Inpatient Hospice Prior Authorization Policy Applies Maximum benefit of 14 Day(s)/Lifetime for In-Network and Out-of-Network	20% Coinsurance after Deductible	40% Coinsurance after Deductible
Inpatient Hospital Facility (including Physician Services billed by Facility) Prior Authorization Policy Applies	20% Coinsurance after Deductible	40% Coinsurance after Deductible
Inpatient Physician Services	20% Coinsurance after Deductible	40% Coinsurance after Deductible
Labs Performed in Office / Independent Lab	No member cost share	40% Coinsurance after Deductible
Maternity Dependent Daughters Maternity Covered?: No	Covered	Covered
Mental Health and Substance Abuse Services - Inpatient Hospital Facility (including Physician Services billed by Facility) Prior Authorization Policy Applies	20% Coinsurance after Deductible	40% Coinsurance after Deductible
Mental Health and Substance Abuse Services - Inpatient Physician Services	20% Coinsurance after Deductible	40% Coinsurance after Deductible
Mental Health and Substance Abuse Services - Office Visit	\$20 Copay/Visit, no Deductible	40% Coinsurance after Deductible
Mental Health and Substance Abuse Services - Outpatient Therapy in a Facility	20% Coinsurance after Deductible	40% Coinsurance after Deductible
Mental Health and Substance Abuse Services - Outpatient Therapy in a Provider's Office	20% Coinsurance after Deductible	40% Coinsurance after Deductible
Nutritional Counseling No Limits Nutritional Counseling Services Covered: Includes all Dx	Subject to Applicable Cost Shares	Subject to Applicable Cost Shares
Organ Transplant Services Prior Authorization Policy Applies	Subject to Applicable Cost Shares Blue Distinction Specialty Care Facility Services: Not applicable	Subject to Applicable Cost Shares
Organ Transplant Travel Expenses	Not covered	Not covered
Other Services Performed in Office	20% Coinsurance after Deductible	40% Coinsurance after Deductible

Outpatient Physician Services	20% Coinsurance after Deductible	40% Coinsurance after Deductible
Outpatient Surgery Prior Authorization Policy Applies	20% Coinsurance after Deductible	40% Coinsurance after Deductible
Outpatient Therapy - Cardiac Therapy No Limits	20% Coinsurance after Deductible	40% Coinsurance after Deductible
Outpatient Therapy - Cognitive Therapy	20% Coinsurance after Deductible	40% Coinsurance after Deductible
Outpatient Therapy - Hearing Therapy in a Facility Combined with Hearing Therapy in a Provider's Office Limits	20% Coinsurance after Deductible	40% Coinsurance after Deductible
Outpatient Therapy - Hearing Therapy in a Provider's Office Combined with Speech Therapy Limits	20% Coinsurance after Deductible	40% Coinsurance after Deductible
Outpatient Therapy - Occupational Therapy in a Facility Combined with Occupational Therapy in a Provider's Office Limits	20% Coinsurance after Deductible	40% Coinsurance after Deductible
Outpatient Therapy - Occupational Therapy in a Provider's Office Combined with Physical Therapy Limits	20% Coinsurance after Deductible	40% Coinsurance after Deductible
Outpatient Therapy - Physical Therapy in a Facility Combined with Physical Therapy in a Provider's Office Limits	20% Coinsurance after Deductible	40% Coinsurance after Deductible
Outpatient Therapy - Physical Therapy in a Provider's Office Maximum benefit of 60 Visit(s)/Calendar Year for In-Network and Out-of-Network	20% Coinsurance after Deductible	40% Coinsurance after Deductible
Outpatient Therapy - Pulmonary Therapy No Limits	20% Coinsurance after Deductible	40% Coinsurance after Deductible
Outpatient Therapy - Skeletal Manipulation Prior Authorization Policy Applies Out-of-Network Combined with Physical Therapy Limits	20% Coinsurance after Deductible	40% Coinsurance after Deductible
Outpatient Therapy - Speech Therapy in a Facility Combined with Speech Therapy in a Provider's Office Limits	20% Coinsurance after Deductible	40% Coinsurance after Deductible
Outpatient Therapy - Speech Therapy in a Provider's Office Maximum benefit of 20 Visit(s)/Calendar Year for In-Network and Out-of-Network	20% Coinsurance after Deductible	40% Coinsurance after Deductible
Private Duty Nursing Combined with Home Health Care Limits	20% Coinsurance after Deductible	40% Coinsurance after Deductible
Routine Preventive Care Diabetes Prevention Program (DPP): Covered Preventive Schedule: PPACA+ (Women's Preventive)	No member cost share	40% Coinsurance after Deductible
Skilled Nursing Facility (SNF) Prior Authorization Policy Applies Maximum benefit of 30 Day(s)/Calendar Year for In-Network and Out-of-Network	20% Coinsurance after Deductible	40% Coinsurance after Deductible
Sports Physicals by a Physician	Not covered	Not covered
Vision Exam-Routine	Not covered	Not covered

Vision Hardware	Not covered	Not covered
Weight Management - Wondr Health	No member cost share	Not Applicable
Wigs	Not covered	Not covered
X-Rays and Radiology INN X-Rays and Radiology Included in Office Visit Copay: No	20% Coinsurance after Deductible	40% Coinsurance after Deductible
5. General Pharmacy Information		
Pharmacy Network(s)	Network 1: RxPremier	
Prescription Drug List Learn more about the drugs covered by your plan, drug category/tier, prior authorization and step therapy by reviewing your prescription drug list on MyBlueKC.com	Premium Formulary	
Outpatient Prescription Drug Deductible You must pay all the costs up to the Deductible amount before this plan begins to pay for covered services. All INN & OON Cross Accum	In-Network Individual :\$200 Family: \$400	Out-of-Network Individual :\$200 Family: \$400
Outpatient Prescription Drug Out-of-Pocket Limits The Out-of-Pocket Limit is the most you could pay during the Calendar Year for your share of the cost of covered services.	In-Network Combined with Medical Out-of-Pocket	Out-of-Network Combined with Medical Out-of-Pocket
Infertility/Impotency Drugs	No limit Combined Medical/Pharmacy limit	
Biosimilar Product Penalty	Applies	
Maintenance Medication Program	Not applicable	
Generics Program	Generics Preferred DAW Rules	
Copay Credit Accumulator Adjustment (CCAA): Specialty drug copay card dollars will not be included in your deductible and/or out-of-pocket limits. Only your true out-of-pocket costs will be applied to your deductible and/or out-of-pocket totals.	Yes	
Variable Copay Solution (VCS): When you use a drug copay card, Specialty prescription drugs may be subject to a new plan benefit cost share. This new cost share will not impact you or the price you pay.	Yes	
Rx Savings Solutions A team of pharmacists and pharmacy technician will help you make sure you're getting the best possible pricing for your medicines. Member support is available Monday – Friday, 7 a.m. to 7 p.m. CST.	Register online at MyBlueKC.com and stay up-to-date on cost saving opportunities. Email: info@rxsavingsllc.com PH: 1-800-268-4476	
6. Plan Benefits – Pharmacy		
	In-Network	Out-of-Network

Retail Pharmacy (Short-term supply: Up to 34 Days) Drug Tier 1: Generic / Generic Specialty	RxPremier: Deductible, then \$12 Copay/Fill	Deductible, then \$12 Copay/Fill, then 50% Coinsurance
Drug Tier 2: Preferred / Preferred Specialty	RxPremier: Deductible, then \$60 Copay/Fill	Deductible, then \$60 Copay/Fill, then 50% Coinsurance
Drug Tier 3: Non-Preferred / Non-Preferred Specialty	RxPremier: Deductible, then \$80 Copay/Fill	Deductible, then \$80 Copay/Fill, then 50% Coinsurance
Retail Pharmacy (Long-term supply: Between 35-102 Days) Drug Tier 1: Generic / Generic Specialty	RxPremier: Deductible, then \$30 Copay/Fill	Deductible, then \$30 Copay/Fill, then 50% Coinsurance
Drug Tier 2: Preferred / Preferred Specialty	RxPremier: Deductible, then \$150 Copay/Fill	Deductible, then \$150 Copay/Fill, then 50% Coinsurance
Drug Tier 3: Non-Preferred / Non-Preferred Specialty	RxPremier: Deductible, then \$200 Copay/Fill	Deductible, then \$200 Copay/Fill, then 50% Coinsurance
Mail Order Pharmacy (Mail Order supply: Between 35-102 Days) Drug Tier 1: Generic	Deductible, then \$24 Copay/Fill	Deductible, then \$24 Copay/Fill, then 50% Coinsurance
Drug Tier 2: Preferred	Deductible, then \$120 Copay/Fill	Deductible, then \$120 Copay/Fill, then 50% Coinsurance
Drug Tier 3: Non-Preferred	Deductible, then \$160 Copay/Fill	Deductible, then \$160 Copay/Fill, then 50% Coinsurance
Infertility Drugs Retail (Short-term supply) Drug Tier 1: Generic / Generic Specialty	RxPremier: Deductible, then \$12 Copay/Fill, then 50% Coinsurance	Deductible, then \$12 Copay/Fill, then 50% Coinsurance
Drug Tier 2: Preferred / Preferred Specialty	RxPremier: Deductible, then \$60 Copay/Fill, then 50% Coinsurance	Deductible, then \$60 Copay/Fill, then 50% Coinsurance
Drug Tier 3: Non-Preferred / Non-Preferred Specialty	RxPremier: Deductible, then \$80 Copay/Fill, then 50% Coinsurance	Deductible, then \$80 Copay/Fill, then 50% Coinsurance
Infertility Drugs Retail (Long-term supply) Drug Tier 1: Generic / Generic Specialty	RxPremier: Deductible, then \$30 Copay/Fill, then 50% Coinsurance	Deductible, then \$30 Copay/Fill, then 50% Coinsurance
Drug Tier 2: Preferred / Preferred Specialty	RxPremier: Deductible, then \$150 Copay/Fill, then 50% Coinsurance	Deductible, then \$150 Copay/Fill, then 50% Coinsurance
Drug Tier 3: Non-Preferred / Non-Preferred Specialty	RxPremier: Deductible, then \$200 Copay/Fill, then 50% Coinsurance	Deductible, then \$200 Copay/Fill, then 50% Coinsurance
Infertility Drugs Mail Order Pharmacy Drug Tier 1: Generic / Generic Specialty	Deductible, then \$24 Copay/Fill, then 50% Coinsurance	Deductible, then \$24 Copay/Fill, then 50% Coinsurance
Drug Tier 2: Preferred / Preferred Specialty	Deductible, then \$120 Copay/Fill, then 50% Coinsurance	Deductible, then \$120 Copay/Fill, then 50% Coinsurance
Drug Tier 3: Non-Preferred / Non-Preferred Specialty	Deductible, then \$160 Copay/Fill, then 50% Coinsurance	Deductible, then \$160 Copay/Fill, then 50% Coinsurance
Impotency Drugs Retail (Short-term supply) Drug Tier 1: Generic / Generic Specialty	RxPremier: Deductible, then \$12 Copay/Fill, then 50% Coinsurance	Deductible, then \$12 Copay/Fill, then 50% Coinsurance

Drug Tier 2: Preferred / Preferred Specialty	RxPremier: Deductible, then \$60 Copay/Fill, then 50% Coinsurance	Deductible, then \$60 Copay/Fill, then 50% Coinsurance
Drug Tier 3: Non-Preferred / Non-Preferred Specialty	RxPremier: Deductible, then \$80 Copay/Fill, then 50% Coinsurance	Deductible, then \$80 Copay/Fill, then 50% Coinsurance
Impotency Drugs Retail (Long-term supply) Drug Tier 1: Generic / Generic Specialty	RxPremier: Deductible, then \$30 Copay/Fill, then 50% Coinsurance	Deductible, then \$30 Copay/Fill, then 50% Coinsurance
Drug Tier 2: Preferred / Preferred Specialty	RxPremier: Deductible, then \$150 Copay/Fill, then 50% Coinsurance	Deductible, then \$150 Copay/Fill, then 50% Coinsurance
Drug Tier 3: Non-Preferred / Non-Preferred Specialty	RxPremier: Deductible, then \$200 Copay/Fill, then 50% Coinsurance	Deductible, then \$200 Copay/Fill, then 50% Coinsurance
Impotency Drugs Mail Order Pharmacy Drug Tier 1: Generic / Generic Specialty	Deductible, then \$24 Copay/Fill, then 50% Coinsurance	Deductible, then \$24 Copay/Fill, then 50% Coinsurance
Drug Tier 2: Preferred / Preferred Specialty	Deductible, then \$120 Copay/Fill, then 50% Coinsurance	Deductible, then \$120 Copay/Fill, then 50% Coinsurance
Drug Tier 3: Non-Preferred / Non-Preferred Specialty	Deductible, then \$160 Copay/Fill, then 50% Coinsurance	Deductible, then \$160 Copay/Fill, then 50% Coinsurance
Weight Loss Drugs	Not covered	Not covered
Abortion Drugs	Not covered	Not covered

This page intentionally left blank



Kansas City

Plan Information	
Group Name:	Unified School District No. 229, Johnson County, State of Kansas
Plan Name:	BlueSelect Plus - EPO Plan
Group Number:	14274000
State:	Kansas
Effective Date:	01/01/2026
Important Notes:	
For Internal Use Only:	Package: 2343470654 XREF: CG2S Medical: 2344250299 Rx: 2344370832
1. General Plan Information	
Benefit Period	Calendar Year
Funding	Cost Plus
Grandfathered Status	Non-Grandfathered
Product Family	EPO
Consumer-Driven Health Plan (CDHP)	N/A
Spira Care Plan?	No
Religious Employer?	N/A
Classification of Eligible Employees	In accordance with group HR policy
Eligibility	
Minimum Participation Rate	Not Applicable
Enrollment Change Threshold	Not Applicable
Minimum Employee Only Contribution	Not Applicable
Minimum Overall Contribution	Not Applicable
COBRA Billing	Employer
Are Domestic Partners Covered?	No
Are Spouses Covered?	Yes
Are Same Sex Spouses Covered?	Yes
Insurance Coverage Creditable (Medicare Part D)	Yes
Clinical Solutions	
Oncology Utilization Management	Yes
Oncology Care Management	Yes
Musculoskeletal (MSK) Utilization Management	Yes
Cardiac Utilization Management	Yes
Blue Connect	Blue Connect Tier Level : Advanced Support Blue Connect PEPM Rate \$2 Connect PEPM Rate \$2 Active Employees? : Yes Retirees Eligible? : Yes COBRA Employees Eligible? : Yes
Smart Shopper	Smart Shopper Included
2. Network	

Local Medical Network	BlueSelect Plus	
Out-of-Area Medical Network	BlueCard PPO/EPO	
Total Care	Total Care is a national program comprised of locally tailored Blue Cross and Blue Shield value-based programs, including Patient-Centered Medical Homes, Accountable Care Organization or similar programs designed to demonstrate results in improving patients' health while managing costs. Members in some plans will have a lower copay if they receive care from a provider in the Total Care program.	
Pharmacy	See Pharmacy (Sections 5 & 6)	
3. Cost Sharing		
Medical Deductible - Calendar Year, Embedded	In-Network	Out-of-Network
Individual	\$0	Does not apply
Family	\$0	Does not apply
Pharmacy Deductible	Separate Deductible (see Pharmacy Section)	
Medical Coinsurance	In-Network	Out-of-Network
Member Pays	Not applicable	Does not apply
Plan Pays	100%	Does not apply
Out-of-Pocket Limit - Calendar Year, Embedded	In-Network	Out-of-Network
The Out-of-Pocket limit includes all Deductibles, Coinsurance, and Copayments a member pays during the Benefit Period.		
Individual	\$4,000	Does not apply
Family	\$10,000	Does not apply
Pharmacy Out-of-Pocket Limit	Combined with Medical	
Annual First Dollar Coverage	Does not apply	Does not apply
Annual Maximum	Does not apply	Does not apply
Lifetime Maximum	Does not apply	Does not apply
4. Benefits		
Professional Services	In-Network	Out-of-Network
Primary Care Physician Office Visit - An internist, family practitioner, general practitioner, or pediatrician.	\$35 Copay/Visit	Not covered
Total Care Primary Care Physician Office Visit	\$15 Copay/Visit	Not applicable
Specialist Physician Office Visit - Doctors of Medicine (MD), Doctors of Osteopathy (DO), except Primary Care Physicians, and other medical practitioners such as optometrists, psychologists and chiropractors.	\$70 Copay/Visit	Not covered
Urgent Care Office Visit	\$70 Copay/Visit	\$70 Copay/Visit
Total Care Urgent Care Office Visit	Does not apply	Not applicable
Blue KC Virtual Care - Office Visit Virtual care provided by Blue KC virtual care partner(s).	\$70 Copay/Visit	Not applicable
Blue KC Virtual Care - Behavioral Health Therapy Virtual care provided by Blue KC virtual care partner(s).	\$15 Copay/Visit	Not applicable
Telehealth - Telehealth Providers other than Blue KC Virtual Care - Office Visit - Primary Care	\$35 Copay/Visit	Not covered
	\$15 Copay/Visit	Not covered

Telehealth - Telehealth Providers other than Blue KC Virtual Care - Office Visit - Behavioral Health		
Telehealth - Telehealth Providers other than Blue KC Virtual Care - Behavioral Health Therapy	\$15 Copay/Visit	Not covered
Designated Health Clinic	Does not apply	Not applicable
Other Benefits (in alphabetical order)	In-Network	Out-of-Network
ABA Services	Subject to Applicable Cost Shares	Not covered
Abortion	Not covered	Not covered
Acupuncture	Not covered	Not covered
Allergy Testing	\$100 Copay/Visit	Not covered
Allergy Treatment	No member cost share	Not covered
Ambulance - Air	No member cost share	No member cost share
Ambulance - Ground Ground Ambulance Allowable Option: 150% of Medicare	No member cost share	No member cost share
Assisted Reproductive Services	Not covered	Not covered
Autism-Related Services No Limits	Subject to Applicable Cost Shares	Not covered
Bariatric Services	Not covered	Not covered
Blue Distinction Specialty Care Facility Services No Limits	Not Applicable	Not covered
Chiropractic Office Visit	\$70 Copay/Visit	Not covered
Dental Anesthesia Maximum age limit of 5 Years	Missouri/Kansas Default	Not covered
Diabetic Equipment and Supplies Prior Authorization Policy Applies In-Network	No member cost share	Not covered
Diabetic Footwear	No member cost share	Not covered
Diabetic Pump	Covered as Durable Medical Equipment (DME)	Not covered
Diabetic Self Management Education/Training (DSMT)	No member cost share	Not covered
Durable Medical Equipment (DME) Prior Authorization Policy Applies In-Network No Limits	No member cost share	Not covered
Elective Male Sterilization	No member cost share	Not covered
Emergency Services Copay Waiver Rule: Copay Waived if Admitted	\$250 Copay/Visit	\$250 Copay/Visit
Food and Food Products for PKU Maximum benefit of \$5,000/Calendar Year for In-Network	Covered	Not covered
Foot Orthotics	Not covered	Not covered
Gender Dysphoria-Related Services Prior Authorization Policy Applies In-Network Gender Dysphoria Cost Shares Apply to Cosmetic Services: No Gender Dysphoria Cost Shares Apply to Non-Surgical Services: Yes Gender Dysphoria Cost Shares Apply to Reassignment Surgery: Yes	Subject to Applicable Cost Shares	Not covered

Hearing Aids	Not covered	Not covered
High Tech Radiology (MRI, MRA, PET, CT) Prior Authorization Policy Applies In-Network High Tech Radiology ER Copay Waiver Rule (when ER Copay also applies): High Tech Radiology Copay Waived	\$250 Copay/Provider per Day	Not covered
Home Health Care Prior Authorization Policy Applies In-Network Maximum benefit of 60 Visit(s)/Calendar Year for In-Network	\$35 Copay/Visit	Not covered
Home Hospice	No member cost share	Not covered
Immunizations - Not Routine Preventive	Not covered	Not covered
Infertility and Impotency Diagnosis & Treatment Infertility and impotency treatment: No limits Medical Dollar limitations include pharmacy: Yes	No member cost share	Not covered
Inpatient Hospice Prior Authorization Policy Applies In-Network Maximum benefit of 14 Day(s)/Lifetime for In-Network Copay Applies to Annual Inpatient/Outpatient Copay Max?: Yes	\$300 Copay/Day Limited to \$3,000 Copay Max per Calendar Year	Not covered
Inpatient Hospital Facility (including Physician Services billed by Facility) Prior Authorization Policy Applies In-Network	\$600 Copay/Day Limited to Inpatient/Outpatient \$3,000 Copay Max per Calendar Year	Not covered
Inpatient Physician Services	No member cost share	Not covered
Labs Performed in Office / Independent Lab	No member cost share	Not covered
Maternity Dependent Daughters Maternity Covered?: No	Covered	Not covered
Mental Health and Substance Abuse Services - Inpatient Hospital Facility (including Physician Services billed by Facility) Prior Authorization Policy Applies In-Network Copay Applies to Annual Inpatient/Outpatient Copay Max?: Yes	\$600 Copay/Day Limited to \$3,000 Copay Max per Calendar Year	Not covered
Mental Health and Substance Abuse Services - Inpatient Physician Services	No member cost share	Not covered
Mental Health and Substance Abuse Services - Office Visit	\$15 Copay/Visit	Not covered
Mental Health and Substance Abuse Services - Outpatient Therapy in a Facility	No member cost share	Not covered
	\$15 Copay/Visit	Not covered

Mental Health and Substance Abuse Services - Outpatient Therapy in a Provider's Office Only one INN copayment will apply if an Office Visit and a MH/SA Therapy Service are performed by a single provider on the same day?: Yes		
Nutritional Counseling No Limits Nutritional Counseling Services Covered: Includes all Dx	Subject to Applicable Cost Shares	Not covered
Organ Transplant Services Prior Authorization Policy Applies In-Network	Subject to Applicable Cost Shares Blue Distinction Specialty Care Facility Services: Not applicable	Not covered
Organ Transplant Travel Expenses	Not covered	Not covered
Other Services Performed in Office	No member cost share	Not covered
Outpatient Physician Services	No member cost share	Not covered
Outpatient Surgery Prior Authorization Policy Applies In-Network Copay Applies to Annual Inpatient/Outpatient Copay Max?: Yes	\$600 Copay/Day Limited to \$3,000 Copay Max per Calendar Year	Not covered
Outpatient Therapy - Cardiac Therapy No Limits	No member cost share	Not covered
Outpatient Therapy - Cognitive Therapy	No member cost share	Not covered
Outpatient Therapy - Hearing Therapy in a Facility Combined with Hearing Therapy in a Provider's Office Limits	No member cost share	Not covered
Outpatient Therapy - Hearing Therapy in a Provider's Office Combined with Speech Therapy Limits	No member cost share	Not covered
Outpatient Therapy - Occupational Therapy in a Facility Combined with Occupational Therapy in a Provider's Office Limits	No member cost share	Not covered
Outpatient Therapy - Occupational Therapy in a Provider's Office Combined with Physical Therapy Limits Only one INN copayment will apply if an Office Visit and a Occupational Therapy Service are performed by a single provider on the same day?: Yes	\$35 Copay/Visit	Not covered
Outpatient Therapy - Physical Therapy in a Facility Combined with Physical Therapy in a Provider's Office Limits	No member cost share	Not covered
Outpatient Therapy - Physical Therapy in a Provider's Office Maximum benefit of 60 Visit(s)/Calendar Year for In-Network Only one INN copayment will apply if an Office Visit and a Physical Therapy Service are performed by a single provider on the same day?: Yes	\$35 Copay/Visit	Not covered

Outpatient Therapy - Pulmonary Therapy No Limits	No member cost share	Not covered
Outpatient Therapy - Skeletal Manipulation Combined with Physical Therapy Limits Only one INN copayment will apply if an Office Visit and a Skeletal Manipulation Therapy Service are performed by a single provider on the same day?: Yes	\$20 Copay/Visit	Not covered
Outpatient Therapy - Speech Therapy in a Facility Combined with Speech Therapy in a Provider's Office Limits	No member cost share	Not covered
Outpatient Therapy - Speech Therapy in a Provider's Office Maximum benefit of 20 Visit(s)/Calendar Year for In-Network Only one INN copayment will apply if an Office Visit and a Speech Therapy Service are performed by a single provider on the same day?: Yes	\$35 Copay/Visit	Not covered
Private Duty Nursing Combined with Home Health Care Limits	No member cost share	Not covered
Routine Preventive Care Diabetes Prevention Program (DPP): Covered Preventive Schedule: PPACA+ (Women's Preventive)	No member cost share	Not covered
Skilled Nursing Facility (SNF) Prior Authorization Policy Applies In-Network Maximum benefit of 30 Day(s)/Calendar Year for In-Network	\$70 Copay/Day Limited to \$350 Copay Max per Calendar Year	Not covered
Sports Physicals by a Physician	Not covered	Not covered
Vision Exam-Routine Maximum benefit of 1 Exam/Calendar Year for In-Network	\$10 Copay/Visit	Not covered
Vision Hardware	Not covered	Not covered
Weight Management - Wondr Health	No member cost share	Not covered
Wigs	Not covered	Not covered
X-Rays and Radiology INN X-Rays and Radiology Included in Office Visit Copay: No	No member cost share	Not covered
5. General Pharmacy Information		
Pharmacy Network(s)	Network 1: RxPremier	
Prescription Drug List Learn more about the drugs covered by your plan, drug category/tier, prior authorization and step therapy by reviewing your prescription drug list on MyBlueKC.com	Premium Formulary	
Outpatient Prescription Drug Deductible	In-Network Individual :\$200 Family: \$400	Out-of-Network Does not apply

You must pay all the costs up to the Deductible amount before this plan begins to pay for covered services.		
Outpatient Prescription Drug Out-of-Pocket Limits The Out-of-Pocket Limit is the most you could pay during the Calendar Year for your share of the cost of covered services.	In-Network Combined with Medical Out-of-Pocket	Out-of-Network Does not apply
Infertility/Impotency Drugs	No limit Combined Medical/Pharmacy limit	
Biosimilar Product Penalty	Applies	
Maintenance Medication Program	Not applicable	
Generics Program	Generics Preferred DAW Rules	
Copay Credit Accumulator Adjustment (CCAA): Specialty drug copay card dollars will not be included in your deductible and/or out-of-pocket limits. Only your true out-of-pocket costs will be applied to your deductible and/or out-of-pocket totals.	Yes	
Variable Copay Solution (VCS): When you use a drug copay card, Specialty prescription drugs may be subject to a new plan benefit cost share. This new cost share will not impact you or the price you pay.	Yes	
Rx Savings Solutions A team of pharmacists and pharmacy technician will help you make sure you're getting the best possible pricing for your medicines. Member support is available Monday – Friday, 7 a.m. to 7 p.m. CST.	Register online at MyBlueKC.com and stay up-to-date on cost saving opportunities. Email: info@rxsavingsllc.com PH: 1-800-268-4476	

6. Plan Benefits – Pharmacy		
	In-Network	Out-of-Network
Retail Pharmacy (Short-term supply: Up to 34 Days) Drug Tier 1: Generic / Generic Specialty	RxPremier: Deductible, then \$12 Copay/Fill	Not covered
Drug Tier 2: Preferred / Preferred Specialty	RxPremier: Deductible, then \$60 Copay/Fill	Not covered
Drug Tier 3: Non-Preferred / Non-Preferred Specialty	RxPremier: Deductible, then \$80 Copay/Fill	Not covered
Retail Pharmacy (Long-term supply: Between 35-102 Days) Drug Tier 1: Generic / Generic Specialty	RxPremier: Deductible, then \$30 Copay/Fill	Not covered
Drug Tier 2: Preferred / Preferred Specialty	RxPremier: Deductible, then \$150 Copay/Fill	Not covered
Drug Tier 3: Non-Preferred / Non-Preferred Specialty	RxPremier: Deductible, then \$200 Copay/Fill	Not covered
	Deductible, then \$24 Copay/Fill	Not covered

Mail Order Pharmacy (Mail Order supply: Between 35-102 Days) Drug Tier 1: Generic		
Drug Tier 2: Preferred	Deductible, then \$120 Copay/Fill	Not covered
Drug Tier 3: Non-Preferred	Deductible, then \$160 Copay/Fill	Not covered
Infertility Drugs Retail (Short-term supply) Drug Tier 1: Generic / Generic Specialty	RxPremier: Deductible, then \$12 Copay/Fill, then 50% Coinsurance	Not covered
Drug Tier 2: Preferred / Preferred Specialty	RxPremier: Deductible, then \$60 Copay/Fill, then 50% Coinsurance	Not covered
Drug Tier 3: Non-Preferred / Non-Preferred Specialty	RxPremier: Deductible, then \$80 Copay/Fill, then 50% Coinsurance	Not covered
Infertility Drugs Retail (Long-term supply) Drug Tier 1: Generic / Generic Specialty	RxPremier: Deductible, then \$30 Copay/Fill, then 50% Coinsurance	Not covered
Drug Tier 2: Preferred / Preferred Specialty	RxPremier: Deductible, then \$150 Copay/Fill, then 50% Coinsurance	Not covered
Drug Tier 3: Non-Preferred / Non-Preferred Specialty	RxPremier: Deductible, then \$200 Copay/Fill, then 50% Coinsurance	Not covered
Infertility Drugs Mail Order Pharmacy Drug Tier 1: Generic / Generic Specialty	Deductible, then \$24 Copay/Fill, then 50% Coinsurance	Not covered
Drug Tier 2: Preferred / Preferred Specialty	Deductible, then \$120 Copay/Fill, then 50% Coinsurance	Not covered
Drug Tier 3: Non-Preferred / Non-Preferred Specialty	Deductible, then \$160 Copay/Fill, then 50% Coinsurance	Not covered
Impotency Drugs Retail (Short-term supply) Drug Tier 1: Generic / Generic Specialty	RxPremier: Deductible, then \$12 Copay/Fill, then 50% Coinsurance	Not covered
Drug Tier 2: Preferred / Preferred Specialty	RxPremier: Deductible, then \$60 Copay/Fill, then 50% Coinsurance	Not covered
Drug Tier 3: Non-Preferred / Non-Preferred Specialty	RxPremier: Deductible, then \$80 Copay/Fill, then 50% Coinsurance	Not covered
Impotency Drugs Retail (Long-term supply) Drug Tier 1: Generic / Generic Specialty	RxPremier: Deductible, then \$30 Copay/Fill, then 50% Coinsurance	Not covered
Drug Tier 2: Preferred / Preferred Specialty	RxPremier: Deductible, then \$150 Copay/Fill, then 50% Coinsurance	Not covered
Drug Tier 3: Non-Preferred / Non-Preferred Specialty	RxPremier: Deductible, then \$200 Copay/Fill, then 50% Coinsurance	Not covered
Impotency Drugs Mail Order Pharmacy Drug Tier 1: Generic / Generic Specialty	Deductible, then \$24 Copay/Fill, then 50% Coinsurance	Not covered
Drug Tier 2: Preferred / Preferred Specialty	Deductible, then \$120 Copay/Fill, then 50% Coinsurance	Not covered

Drug Tier 3: Non-Preferred / Non-Preferred Specialty	Deductible, then \$160 Copay/Fill, then 50% Coinsurance	Not covered
Weight Loss Drugs	Not covered	Not covered
Abortion Drugs	Not covered	Not covered

This page intentionally left blank



Kansas City

Plan Information	
Group Name:	Unified School District No. 229, Johnson County, State of Kansas
Plan Name:	Preferred-Care Blue - BlueSaver Plan
Group Number:	14274000
State:	Kansas
Effective Date:	01/01/2026
Important Notes:	
For Internal Use Only:	Package: 2343440123 XREF: CG2R Medical: 2344290128 Rx: 2344400488
1. General Plan Information	
Benefit Period	Calendar Year
Funding	Cost Plus
Grandfathered Status	Non-Grandfathered
Product Family	PPO
Consumer-Driven Health Plan (CDHP)	HSA
Spira Care Plan?	No
Religious Employer?	N/A
Classification of Eligible Employees	In accordance with group HR policy
Eligibility	
Minimum Participation Rate	Not Applicable
Enrollment Change Threshold	Not Applicable
Minimum Employee Only Contribution	Not Applicable
Minimum Overall Contribution	Not Applicable
COBRA Billing	Employer
Are Domestic Partners Covered?	No
Are Spouses Covered?	Yes
Are Same Sex Spouses Covered?	Yes
Insurance Coverage Creditable (Medicare Part D)	Yes
Clinical Solutions	
Oncology Utilization Management	Yes
Oncology Care Management	Yes
Musculoskeletal (MSK) Utilization Management	Yes
Cardiac Utilization Management	Yes
Blue Connect	Blue Connect Tier Level : Advanced Support Blue Connect PEPM Rate \$2 Connect PEPM Rate \$2 Active Employees? : Yes Retirees Eligible? : Yes COBRA Employees Eligible? : Yes
Smart Shopper	Smart Shopper Included
2. Network	

Local Medical Network	Preferred-Care Blue Services rendered at Out-of-Network providers are subject to Out-of-Network allowables as stated in your contract, and balance billing may occur.	
Out-of-Area Medical Network	BlueCard PPO/EPO	
Total Care	Total Care is a national program comprised of locally tailored Blue Cross and Blue Shield value-based programs, including Patient-Centered Medical Homes, Accountable Care Organization or similar programs designed to demonstrate results in improving patients' health while managing costs. Members in some plans will have a lower copay if they receive care from a provider in the Total Care program.	
Pharmacy	See Pharmacy (Sections 5 & 6)	
3. Cost Sharing		
Medical Deductible - Calendar Year, Embedded All INN & OON Cross Accum	In-Network	Out-of-Network
Individual	\$3,400	\$3,400
Family	\$8,250	\$8,250
Pharmacy Deductible	Combined with Medical	
Medical Coinsurance	In-Network	Out-of-Network
Member Pays	20%	40%
Plan Pays	80%	60%
Out-of-Pocket Limit - Calendar Year, Embedded All INN & OON Cross Accum The Out-of-Pocket limit includes all Deductibles, Coinsurance, and Copayments a member pays during the Benefit Period.	In-Network	Out-of-Network
Individual	\$5,000	\$6,800
Family	\$12,500	\$16,500
Pharmacy Out-of-Pocket Limit	Combined with Medical	
Annual First Dollar Coverage	Does not apply	Does not apply
Annual Maximum	Does not apply	Does not apply
Lifetime Maximum	Does not apply	Does not apply
4. Benefits		
Professional Services	In-Network	Out-of-Network
Primary Care Physician Office Visit - An internist, family practitioner, general practitioner, or pediatrician.	20% Coinsurance after Deductible	40% Coinsurance after Deductible
Total Care Primary Care Physician Office Visit	20% Coinsurance after Deductible	Not applicable
Specialist Physician Office Visit - Doctors of Medicine (MD), Doctors of Osteopathy (DO), except Primary Care Physicians, and other medical practitioners such as optometrists, psychologists and chiropractors.	20% Coinsurance after Deductible	40% Coinsurance after Deductible
Urgent Care Office Visit	20% Coinsurance after Deductible	40% Coinsurance after Deductible
Total Care Urgent Care Office Visit	Does not apply	Not applicable
Blue KC Virtual Care - Office Visit Virtual care provided by Blue KC virtual care partner(s).	20% Coinsurance after Deductible	Not applicable
Blue KC Virtual Care - Behavioral Health Therapy Virtual care provided by Blue KC virtual care partner(s).	20% Coinsurance after Deductible	Not applicable
	20% Coinsurance after Deductible	40% Coinsurance after Deductible

Telehealth - Telehealth Providers other than Blue KC Virtual Care - Office Visit - Primary Care		
Telehealth - Telehealth Providers other than Blue KC Virtual Care - Office Visit - Behavioral Health	20% Coinsurance after Deductible	40% Coinsurance after Deductible
Telehealth - Telehealth Providers other than Blue KC Virtual Care - Behavioral Health Therapy	20% Coinsurance after Deductible	40% Coinsurance after Deductible
Designated Health Clinic	Does not apply	Not applicable
Other Benefits (in alphabetical order)	In-Network	Out-of-Network
ABA Services	Subject to Applicable Cost Shares	Subject to Applicable Cost Shares
Abortion	Not covered	Not covered
Acupuncture	Not covered	Not covered
Allergy Testing	20% Coinsurance after Deductible	40% Coinsurance after Deductible
Allergy Treatment	20% Coinsurance after Deductible	40% Coinsurance after Deductible
Ambulance - Air	20% Coinsurance after Deductible	20% Coinsurance after In-Network Deductible
Ambulance - Ground Ground Ambulance Allowable Option: 150% of Medicare	20% Coinsurance after Deductible	20% Coinsurance after In-Network Deductible
Assisted Reproductive Services	Not covered	Not covered
Autism-Related Services No Limits	Subject to Applicable Cost Shares	Subject to Applicable Cost Shares
Bariatric Services	Not covered	Not covered
Blue Distinction Specialty Care Facility Services No Limits	Not Applicable	Not Applicable
Chiropractic Office Visit	20% Coinsurance after Deductible	40% Coinsurance after Deductible
Dental Anesthesia Maximum age limit of 5 Years	Missouri/Kansas Default	Missouri/Kansas Default
Diabetic Equipment and Supplies Prior Authorization Policy Applies	20% Coinsurance after Deductible	40% Coinsurance after Deductible
Diabetic Footwear	20% Coinsurance after Deductible	40% Coinsurance after Deductible
Diabetic Pump	Covered as Durable Medical Equipment (DME)	Covered as Durable Medical Equipment (DME)
Diabetic Self Management Education/Training (DSMT)	No member cost share	40% Coinsurance after Deductible
Durable Medical Equipment (DME) Prior Authorization Policy Applies No Limits	20% Coinsurance after Deductible	40% Coinsurance after Deductible
Elective Male Sterilization	Deductible, then no charge	40% Coinsurance after Deductible
Emergency Services	20% Coinsurance after Deductible	20% Coinsurance after In-Network Deductible
Food and Food Products for PKU Maximum benefit of \$5,000/Calendar Year for In-Network and Out-of-Network	Covered	Covered
Foot Orthotics	Not covered	Not covered
Gender Dysphoria-Related Services Prior Authorization Policy Applies Gender Dysphoria Cost Shares Apply to Cosmetic Services: No Gender Dysphoria Cost Shares Apply to Non-Surgical Services: Yes Gender Dysphoria Cost Shares Apply to Reassignment Surgery: Yes	Subject to Applicable Cost Shares	Subject to Applicable Cost Shares

Hearing Aids	Not covered	Not covered
High Tech Radiology (MRI, MRA, PET, CT) Prior Authorization Policy Applies	20% Coinsurance after Deductible	40% Coinsurance after Deductible
Home Health Care Prior Authorization Policy Applies Maximum benefit of 60 Visit(s)/Calendar Year for In-Network and Out-of-Network	20% Coinsurance after Deductible	40% Coinsurance after Deductible
Home Hospice	20% Coinsurance after Deductible	40% Coinsurance after Deductible
Immunizations - Not Routine Preventive	Not covered	Not covered
Infertility and Impotency Diagnosis & Treatment Infertility and impotency treatment: No limits Medical Dollar limitations include pharmacy: Yes	20% Coinsurance after Deductible	40% Coinsurance after Deductible
Inpatient Hospice Prior Authorization Policy Applies Maximum benefit of 14 Day(s)/Lifetime for In-Network and Out-of-Network	20% Coinsurance after Deductible	40% Coinsurance after Deductible
Inpatient Hospital Facility (including Physician Services billed by Facility) Prior Authorization Policy Applies	20% Coinsurance after Deductible	40% Coinsurance after Deductible
Inpatient Physician Services	20% Coinsurance after Deductible	40% Coinsurance after Deductible
Labs Performed in Office / Independent Lab	20% Coinsurance after Deductible	40% Coinsurance after Deductible
Maternity Dependent Daughters Maternity Covered?: No	Covered	Covered
Mental Health and Substance Abuse Services - Inpatient Hospital Facility (including Physician Services billed by Facility) Prior Authorization Policy Applies	20% Coinsurance after Deductible	40% Coinsurance after Deductible
Mental Health and Substance Abuse Services - Inpatient Physician Services	20% Coinsurance after Deductible	40% Coinsurance after Deductible
Mental Health and Substance Abuse Services - Office Visit	20% Coinsurance after Deductible	40% Coinsurance after Deductible
Mental Health and Substance Abuse Services - Outpatient Therapy in a Facility	20% Coinsurance after Deductible	40% Coinsurance after Deductible
Mental Health and Substance Abuse Services - Outpatient Therapy in a Provider's Office	20% Coinsurance after Deductible	40% Coinsurance after Deductible
Nutritional Counseling No Limits Nutritional Counseling Services Covered: Includes all Dx	Subject to Applicable Cost Shares	Subject to Applicable Cost Shares
Organ Transplant Services Prior Authorization Policy Applies	Subject to Applicable Cost Shares Blue Distinction Specialty Care Facility Services: Not applicable	Subject to Applicable Cost Shares
Organ Transplant Travel Expenses	Not covered	Not covered
Other Services Performed in Office	20% Coinsurance after Deductible	40% Coinsurance after Deductible
Outpatient Physician Services	20% Coinsurance after Deductible	40% Coinsurance after Deductible
Outpatient Surgery Prior Authorization Policy Applies	20% Coinsurance after Deductible	40% Coinsurance after Deductible

Outpatient Therapy - Cardiac Therapy No Limits	20% Coinsurance after Deductible	40% Coinsurance after Deductible
Outpatient Therapy - Cognitive Therapy	20% Coinsurance after Deductible	40% Coinsurance after Deductible
Outpatient Therapy - Hearing Therapy in a Facility Combined with Hearing Therapy in a Provider's Office Limits	20% Coinsurance after Deductible	40% Coinsurance after Deductible
Outpatient Therapy - Hearing Therapy in a Provider's Office Combined with Speech Therapy Limits	20% Coinsurance after Deductible	40% Coinsurance after Deductible
Outpatient Therapy - Occupational Therapy in a Facility Combined with Occupational Therapy in a Provider's Office Limits	20% Coinsurance after Deductible	40% Coinsurance after Deductible
Outpatient Therapy - Occupational Therapy in a Provider's Office Combined with Physical Therapy Limits	20% Coinsurance after Deductible	40% Coinsurance after Deductible
Outpatient Therapy - Physical Therapy in a Facility Combined with Physical Therapy in a Provider's Office Limits	20% Coinsurance after Deductible	40% Coinsurance after Deductible
Outpatient Therapy - Physical Therapy in a Provider's Office Maximum benefit of 60 Visit(s)/Calendar Year for In-Network and Out-of-Network	20% Coinsurance after Deductible	40% Coinsurance after Deductible
Outpatient Therapy - Pulmonary Therapy No Limits	20% Coinsurance after Deductible	40% Coinsurance after Deductible
Outpatient Therapy - Skeletal Manipulation Prior Authorization Policy Applies Out-of-Network Combined with Physical Therapy Limits	20% Coinsurance after Deductible	40% Coinsurance after Deductible
Outpatient Therapy - Speech Therapy in a Facility Combined with Speech Therapy in a Provider's Office Limits	20% Coinsurance after Deductible	40% Coinsurance after Deductible
Outpatient Therapy - Speech Therapy in a Provider's Office Maximum benefit of 20 Visit(s)/Calendar Year for In-Network and Out-of-Network	20% Coinsurance after Deductible	40% Coinsurance after Deductible
Private Duty Nursing Combined with Home Health Care Limits	20% Coinsurance after Deductible	40% Coinsurance after Deductible
Routine Preventive Care Diabetes Prevention Program (DPP): Covered Preventive Schedule: PPACA+ (Women's Preventive)	No member cost share	40% Coinsurance after Deductible
Skilled Nursing Facility (SNF) Prior Authorization Policy Applies Maximum benefit of 30 Day(s)/Calendar Year for In-Network and Out-of-Network	20% Coinsurance after Deductible	40% Coinsurance after Deductible
Sports Physicals by a Physician	Not covered	Not covered
Vision Exam-Routine	Not covered	Not covered
Vision Hardware	Not covered	Not covered
Weight Management - Wondr Health	No member cost share	Not Applicable
Wigs	Not covered	Not covered

X-Rays and Radiology	20% Coinsurance after Deductible	40% Coinsurance after Deductible
5. General Pharmacy Information		
Pharmacy Network(s)	Network 1: RxPremier	
Prescription Drug List Learn more about the drugs covered by your plan, drug category/tier, prior authorization and step therapy by reviewing your prescription drug list on MyBlueKC.com	Premium Formulary	
Outpatient Prescription Drug Deductible You must pay all the costs up to the Deductible amount before this plan begins to pay for covered services.	In-Network Combined with Medical Deductible	Out-of-Network Combined with Medical Deductible
Outpatient Prescription Drug Out-of-Pocket Limits The Out-of-Pocket Limit is the most you could pay during the Calendar Year for your share of the cost of covered services.	In-Network Combined with Medical Out-of-Pocket	Out-of-Network Combined with Medical Out-of-Pocket
Infertility/Impotency Drugs	No limit Combined Medical/Pharmacy limit	
Biosimilar Product Penalty	Applies	
Maintenance Medication Program	Not applicable	
Generics Program	Not Applicable	
Copay Credit Accumulator Adjustment (CCAA): Specialty drug copay card dollars will not be included in your deductible and/or out-of-pocket limits. Only your true out-of-pocket costs will be applied to your deductible and/or out-of-pocket totals.	Yes	
Variable Copay Solution (VCS): When you use a drug copay card, Specialty prescription drugs may be subject to a new plan benefit cost share. This new cost share will not impact you or the price you pay.	No	
Rx Savings Solutions A team of pharmacists and pharmacy technician will help you make sure you're getting the best possible pricing for your medicines. Member support is available Monday – Friday, 7 a.m. to 7 p.m. CST.	Register online at MyBlueKC.com and stay up-to-date on cost saving opportunities. Email: info@rxsavingsllc.com PH: 1-800-268-4476	
6. Plan Benefits – Pharmacy		
	In-Network	Out-of-Network
Retail Pharmacy (Short-term supply: Up to 34 Days) Drug Tier 1: Generic / Generic Specialty	RxPremier: Deductible, then 20% Coinsurance	Deductible, then \$12 Copay/Fill, then 50% Coinsurance
Drug Tier 2: Preferred / Preferred Specialty	RxPremier: Deductible, then 20% Coinsurance	Deductible, then \$60 Copay/Fill, then 50% Coinsurance

Drug Tier 3: Non-Preferred / Non-Preferred Specialty	RxPremier: Deductible, then 20% Coinsurance	Deductible, then \$80 Copay/Fill, then 50% Coinsurance
Retail Pharmacy (Long-term supply: Between 35-102 Days) Drug Tier 1: Generic / Generic Specialty	RxPremier: Deductible, then 20% Coinsurance	Deductible, then \$30 Copay/Fill, then 50% Coinsurance
Drug Tier 2: Preferred / Preferred Specialty	RxPremier: Deductible, then 20% Coinsurance	Deductible, then \$150 Copay/Fill, then 50% Coinsurance
Drug Tier 3: Non-Preferred / Non-Preferred Specialty	RxPremier: Deductible, then 20% Coinsurance	Deductible, then \$200 Copay/Fill, then 50% Coinsurance
Mail Order Pharmacy (Mail Order supply: Between 35-102 Days) Drug Tier 1: Generic	Deductible, then 20% Coinsurance	Deductible, then \$24 Copay/Fill, then 50% Coinsurance
Drug Tier 2: Preferred	Deductible, then 20% Coinsurance	Deductible, then \$120 Copay/Fill, then 50% Coinsurance
Drug Tier 3: Non-Preferred	Deductible, then 20% Coinsurance	Deductible, then \$160 Copay/Fill, then 50% Coinsurance
Preventive Drugs Retail (Short-Term) Drug Tier 1: Generic / Generic Specialty	RxPremier: Deductible, then 20% Coinsurance	Deductible, then \$12 Copay/Fill, then 50% Coinsurance
Retail (Short-Term) Drug Tier 2: Preferred / Preferred Specialty	RxPremier: Deductible, then 20% Coinsurance	Deductible, then \$60 Copay/Fill, then 50% Coinsurance
Retail (Short-Term) Drug Tier 3: Non-Preferred / Non-Preferred Specialty	RxPremier: Deductible, then 20% Coinsurance	Deductible, then \$80 Copay/Fill, then 50% Coinsurance
Retail (Long-Term) Drug Tier 1: Generic / Generic Specialty	RxPremier: Deductible, then 20% Coinsurance	Deductible, then \$30 Copay/Fill, then 50% Coinsurance
Retail (Long-Term) Drug Tier 2: Preferred / Preferred Specialty	RxPremier: Deductible, then 20% Coinsurance	Deductible, then \$150 Copay/Fill, then 50% Coinsurance
Retail (Long-Term) Drug Tier 3: Non-Preferred / Non-Preferred Specialty	RxPremier: Deductible, then 20% Coinsurance	Deductible, then \$200 Copay/Fill, then 50% Coinsurance
Mail Order Drug Tier 1: Generic / Generic Specialty	Deductible, then 20% Coinsurance	Deductible, then \$24 Copay/Fill, then 50% Coinsurance
Mail Order Drug Tier 2: Preferred / Preferred Specialty	Deductible, then 20% Coinsurance	Deductible, then \$120 Copay/Fill, then 50% Coinsurance
Mail Order Drug Tier 3: Non-Preferred / Non-Preferred Specialty	Deductible, then 20% Coinsurance	Deductible, then \$160 Copay/Fill, then 50% Coinsurance
Infertility Drugs Retail (Short-term supply) Drug Tier 1: Generic / Generic Specialty	RxPremier: Deductible, then 50% Coinsurance	Deductible, then \$12 Copay/Fill, then 50% Coinsurance
Drug Tier 2: Preferred / Preferred Specialty	RxPremier: Deductible, then 50% Coinsurance	Deductible, then \$60 Copay/Fill, then 50% Coinsurance
Drug Tier 3: Non-Preferred / Non-Preferred Specialty	RxPremier: Deductible, then 50% Coinsurance	Deductible, then \$80 Copay/Fill, then 50% Coinsurance
Infertility Drugs Retail (Long-term supply) Drug Tier 1: Generic / Generic Specialty	RxPremier: Deductible, then 50% Coinsurance	Deductible, then \$30 Copay/Fill, then 50% Coinsurance

Drug Tier 2: Preferred / Preferred Specialty	RxPremier: Deductible, then 50% Coinsurance	Deductible, then \$150 Copay/Fill, then 50% Coinsurance
Drug Tier 3: Non-Preferred / Non-Preferred Specialty	RxPremier: Deductible, then 50% Coinsurance	Deductible, then \$200 Copay/Fill, then 50% Coinsurance
Infertility Drugs Mail Order Pharmacy Drug Tier 1: Generic / Generic Specialty	Deductible, then 50% Coinsurance	Deductible, then \$24 Copay/Fill, then 50% Coinsurance
Drug Tier 2: Preferred / Preferred Specialty	Deductible, then 50% Coinsurance	Deductible, then \$120 Copay/Fill, then 50% Coinsurance
Drug Tier 3: Non-Preferred / Non-Preferred Specialty	Deductible, then 50% Coinsurance	Deductible, then \$160 Copay/Fill, then 50% Coinsurance
Impotency Drugs Retail (Short-term supply) Drug Tier 1: Generic / Generic Specialty	RxPremier: Deductible, then 50% Coinsurance	Deductible, then \$12 Copay/Fill, then 50% Coinsurance
Drug Tier 2: Preferred / Preferred Specialty	RxPremier: Deductible, then 50% Coinsurance	Deductible, then \$60 Copay/Fill, then 50% Coinsurance
Drug Tier 3: Non-Preferred / Non-Preferred Specialty	RxPremier: Deductible, then 50% Coinsurance	Deductible, then \$80 Copay/Fill, then 50% Coinsurance
Impotency Drugs Retail (Long-term supply) Drug Tier 1: Generic / Generic Specialty	RxPremier: Deductible, then 50% Coinsurance	Deductible, then \$30 Copay/Fill, then 50% Coinsurance
Drug Tier 2: Preferred / Preferred Specialty	RxPremier: Deductible, then 50% Coinsurance	Deductible, then \$150 Copay/Fill, then 50% Coinsurance
Drug Tier 3: Non-Preferred / Non-Preferred Specialty	RxPremier: Deductible, then 50% Coinsurance	Deductible, then \$200 Copay/Fill, then 50% Coinsurance
Impotency Drugs Mail Order Pharmacy Drug Tier 1: Generic / Generic Specialty	Deductible, then 50% Coinsurance	Deductible, then \$24 Copay/Fill, then 50% Coinsurance
Drug Tier 2: Preferred / Preferred Specialty	Deductible, then 50% Coinsurance	Deductible, then \$120 Copay/Fill, then 50% Coinsurance
Drug Tier 3: Non-Preferred / Non-Preferred Specialty	Deductible, then 50% Coinsurance	Deductible, then \$160 Copay/Fill, then 50% Coinsurance
Weight Loss Drugs	Not covered	Not covered
Abortion Drugs	Not covered	Not covered

This page intentionally left blank



Kansas City

Plan Information	
Group Name:	Unified School District No. 229, Johnson County, State of Kansas
Plan Name:	BlueSelect Plus - SPIRA EPO Plan
Group Number:	14274000
State:	Kansas
Effective Date:	01/01/2026
Important Notes:	
For Internal Use Only:	Package: 2343510311 XREF: CG2T Medical: 2344080704 Rx: 2344120860
1. General Plan Information	
Benefit Period	Calendar Year
Funding	Cost Plus
Grandfathered Status	Non-Grandfathered
Product Family	EPO
Consumer-Driven Health Plan (CDHP)	N/A
Spira Care Plan?	Yes No charge for services received from a designated Spira Care Center Provider. Treatment of work-related injury or illness is not covered under your Blue Cross and Blue Shield of Kansas City health benefit plan. Treatment of work-related injuries and illnesses is typically provided through your workers' compensation program. The Spira Care clinics are not participating providers under workers' compensation programs. Please reference your workers' compensation policies and procedures to direct your employees appropriately for work-related injuries.
Religious Employer?	N/A
Classification of Eligible Employees	In accordance with group HR policy
Eligibility	
Minimum Participation Rate	Not Applicable
Enrollment Change Threshold	Not Applicable
Minimum Employee Only Contribution	Not Applicable
Minimum Overall Contribution	Not Applicable
COBRA Billing	Employer
Are Domestic Partners Covered?	No
Are Spouses Covered?	Yes
Are Same Sex Spouses Covered?	Yes
Insurance Coverage Creditable (Medicare Part D)	Yes
Clinical Solutions	
Oncology Utilization Management	Yes
Oncology Care Management	Yes
Musculoskeletal (MSK) Utilization Management	Yes
Cardiac Utilization Management	Yes

Blue Connect	Blue Connect Tier Level : Advanced Support Blue Connect PEPM Rate \$2 Connect PEPM Rate \$2 Active Employees? : Yes Retirees Eligible? : Yes COBRA Employees Eligible? : Yes	
Smart Shopper	Smart Shopper Included	
2. Network		
Local Medical Network	BlueSelect Plus	
Out-of-Area Medical Network	BlueCard PPO/EPO	
Pharmacy	See Pharmacy (Sections 5 & 6)	
3. Cost Sharing		
Medical Deductible - Calendar Year, Embedded	In-Network	Out-of-Network
Individual	\$1,500	Does not apply
Family	\$4,500	Does not apply
Pharmacy Deductible	Combined with Medical	
Medical Coinsurance	In-Network	Out-of-Network
Member Pays	Not applicable	Does not apply
Plan Pays	100%	Does not apply
Out-of-Pocket Limit - Calendar Year, Embedded The Out-of-Pocket limit includes all Deductibles, Coinsurance, and Copayments a member pays during the Benefit Period.	In-Network	Out-of-Network
Individual	\$1,500	Does not apply
Family	\$4,500	Does not apply
Pharmacy Out-of-Pocket Limit	Combined with Medical	
Annual First Dollar Coverage	Does not apply	Does not apply
Annual Maximum	Does not apply	Does not apply
Lifetime Maximum	Does not apply	Does not apply
4. Benefits		
Professional Services	In-Network	Out-of-Network
Primary Care Physician Office Visit - An internist, family practitioner, general practitioner, or pediatrician.	Deductible, then no charge	Not covered
Total Care Primary Care Physician Office Visit	Does not apply	Not applicable
Specialist Physician Office Visit - Doctors of Medicine (MD), Doctors of Osteopathy (DO), except Primary Care Physicians, and other medical practitioners such as optometrists, psychologists and chiropractors.	Deductible, then no charge	Not covered
Urgent Care Office Visit	Deductible, then no charge	In-Network Deductible, then no charge
Total Care Urgent Care Office Visit	Does not apply	Not applicable
Blue KC Virtual Care - Office Visit Virtual care provided by Blue KC virtual care partner(s).	No member cost share	Not applicable
Blue KC Virtual Care - Behavioral Health Therapy Virtual care provided by Blue KC virtual care partner(s).	Deductible, then no charge	Not applicable
	Deductible, then no charge	Not covered

Telehealth - Telehealth Providers other than Blue KC Virtual Care - Office Visit - Primary Care		
Telehealth - Telehealth Providers other than Blue KC Virtual Care - Office Visit - Behavioral Health	Deductible, then no charge	Not covered
Telehealth - Telehealth Providers other than Blue KC Virtual Care - Behavioral Health Therapy	Deductible, then no charge	Not covered
Designated Health Clinic	Does not apply	Not applicable
Other Benefits (in alphabetical order)	In-Network	Out-of-Network
ABA Services	Subject to Applicable Cost Shares	Not covered
Abortion	Not covered	Not covered
Acupuncture	Not covered	Not covered
Allergy Testing	Deductible, then no charge	Not covered
Allergy Treatment	Deductible, then no charge	Not covered
Ambulance - Air	Deductible, then no charge	In-Network Deductible, then no charge
Ambulance - Ground Ground Ambulance Allowable Option: 150% of Medicare	Deductible, then no charge	In-Network Deductible, then no charge
Assisted Reproductive Services	Not covered	Not covered
Autism-Related Services No Limits	Subject to Applicable Cost Shares	Not covered
Bariatric Services	Not covered	Not covered
Blue Distinction Specialty Care Facility Services No Limits	Not Applicable	Not covered
Chiropractic Office Visit	Deductible, then no charge	Not covered
Dental Anesthesia Maximum age limit of 5 Years	Missouri/Kansas Default	Not covered
Diabetic Equipment and Supplies Prior Authorization Policy Applies In-Network	Deductible, then no charge	Not covered
Diabetic Footwear	Deductible, then no charge	Not covered
Diabetic Pump	Covered as Durable Medical Equipment (DME)	Not covered
Diabetic Self Management Education/Training (DSMT)	No member cost share	Not covered
Durable Medical Equipment (DME) Prior Authorization Policy Applies In-Network No Limits	Deductible, then no charge	Not covered
Elective Male Sterilization	No member cost share	Not covered
Emergency Services	Deductible, then no charge	In-Network Deductible, then no charge
Food and Food Products for PKU Maximum benefit of \$5,000/Calendar Year for In-Network	Covered	Not covered
Foot Orthotics	Not covered	Not covered
Gender Dysphoria-Related Services Prior Authorization Policy Applies In-Network Gender Dysphoria Cost Shares Apply to Cosmetic Services: No Gender Dysphoria Cost Shares Apply to Non-Surgical Services: Yes Gender Dysphoria Cost Shares Apply to Reassignment Surgery: Yes	Subject to Applicable Cost Shares	Not covered

Hearing Aids	Not covered	Not covered
High Tech Radiology (MRI, MRA, PET, CT) Prior Authorization Policy Applies In-Network	Deductible, then no charge	Not covered
Home Health Care Prior Authorization Policy Applies In-Network Maximum benefit of 60 Visit(s)/Calendar Year for In-Network	Deductible, then no charge	Not covered
Home Hospice	Deductible, then no charge	Not covered
Immunizations - Not Routine Preventive	Not covered	Not covered
Infertility and Impotency Diagnosis & Treatment Infertility and impotency treatment: No limits Medical Dollar limitations include pharmacy: Yes	Deductible, then no charge	Not covered
Inpatient Hospice Prior Authorization Policy Applies In-Network Maximum benefit of 14 Day(s)/Lifetime for In-Network	Deductible, then no charge	Not covered
Inpatient Hospital Facility (including Physician Services billed by Facility) Prior Authorization Policy Applies In-Network	Deductible, then no charge	Not covered
Inpatient Physician Services	Deductible, then no charge	Not covered
Labs Performed in Office / Independent Lab	Deductible, then no charge	Not covered
Maternity Dependent Daughters Maternity Covered?: No	Covered	Not covered
Mental Health and Substance Abuse Services - Inpatient Hospital Facility (including Physician Services billed by Facility) Prior Authorization Policy Applies In-Network	Deductible, then no charge	Not covered
Mental Health and Substance Abuse Services - Inpatient Physician Services	Deductible, then no charge	Not covered
Mental Health and Substance Abuse Services - Office Visit	Deductible, then no charge	Not covered
Mental Health and Substance Abuse Services - Outpatient Therapy in a Facility	Deductible, then no charge	Not covered
Mental Health and Substance Abuse Services - Outpatient Therapy in a Provider's Office	Deductible, then no charge	Not covered
Nutritional Counseling No Limits Nutritional Counseling Services Covered: Includes all Dx	Subject to Applicable Cost Shares	Not covered
Organ Transplant Services Prior Authorization Policy Applies In-Network	Subject to Applicable Cost Shares Blue Distinction Specialty Care Facility Services: Not applicable	Not covered

Organ Transplant Travel Expenses	Not covered	Not covered
Other Services Performed in Office	Deductible, then no charge	Not covered
Outpatient Physician Services	Deductible, then no charge	Not covered
Outpatient Surgery Prior Authorization Policy Applies In-Network	Deductible, then no charge	Not covered
Outpatient Therapy - Cardiac Therapy No Limits	Deductible, then no charge	Not covered
Outpatient Therapy - Cognitive Therapy	Deductible, then no charge	Not covered
Outpatient Therapy - Hearing Therapy in a Facility Combined with Hearing Therapy in a Provider's Office Limits	Deductible, then no charge	Not covered
Outpatient Therapy - Hearing Therapy in a Provider's Office Combined with Speech Therapy Limits	Deductible, then no charge	Not covered
Outpatient Therapy - Occupational Therapy in a Facility Combined with Occupational Therapy in a Provider's Office Limits	Deductible, then no charge	Not covered
Outpatient Therapy - Occupational Therapy in a Provider's Office Combined with Physical Therapy Limits	Deductible, then no charge	Not covered
Outpatient Therapy - Physical Therapy in a Facility Combined with Physical Therapy in a Provider's Office Limits	Deductible, then no charge	Not covered
Outpatient Therapy - Physical Therapy in a Provider's Office Maximum benefit of 60 Visit(s)/Calendar Year for In-Network	Deductible, then no charge	Not covered
Outpatient Therapy - Pulmonary Therapy No Limits	Deductible, then no charge	Not covered
Outpatient Therapy - Skeletal Manipulation Combined with Physical Therapy Limits	Deductible, then no charge	Not covered
Outpatient Therapy - Speech Therapy in a Facility Combined with Speech Therapy in a Provider's Office Limits	Deductible, then no charge	Not covered
Outpatient Therapy - Speech Therapy in a Provider's Office Maximum benefit of 20 Visit(s)/Calendar Year for In-Network	Deductible, then no charge	Not covered
Private Duty Nursing Combined with Home Health Care Limits	Deductible, then no charge	Not covered
Routine Preventive Care Diabetes Prevention Program (DPP): Covered Preventive Schedule: PPACA+ (Women's Preventive)	No member cost share	Not covered
Skilled Nursing Facility (SNF) Prior Authorization Policy Applies In-Network Maximum benefit of 30 Day(s)/Calendar Year for In-Network	Deductible, then no charge	Not covered

Sports Physicals by a Physician	Not covered	Not covered
Vision Exam-Routine	Not covered	Not covered
Vision Hardware	Not covered	Not covered
Weight Management - Wondr Health	No member cost share	Not covered
Wigs	Not covered	Not covered
X-Rays and Radiology	Deductible, then no charge	Not covered
5. General Pharmacy Information		
Pharmacy Network(s)	Network 1: RxPremier	
Prescription Drug List Learn more about the drugs covered by your plan, drug category/tier, prior authorization and step therapy by reviewing your prescription drug list on MyBlueKC.com	Premium Formulary	
Outpatient Prescription Drug Deductible You must pay all the costs up to the Deductible amount before this plan begins to pay for covered services.	In-Network Combined with Medical Deductible	Out-of-Network Does not Apply
Outpatient Prescription Drug Out-of-Pocket Limits The Out-of-Pocket Limit is the most you could pay during the Calendar Year for your share of the cost of covered services.	In-Network Combined with Medical Out-of-Pocket	Out-of-Network Does not apply
Infertility/Impotency Drugs	No limit Combined Medical/Pharmacy limit	
Biosimilar Product Penalty	Applies	
Maintenance Medication Program	Not applicable	
Generics Program	Not Applicable	
Copay Credit Accumulator Adjustment (CCA): Specialty drug copay card dollars will not be included in your deductible and/or out-of-pocket limits. Only your true out-of-pocket costs will be applied to your deductible and/or out-of-pocket totals.	Yes	
Variable Copay Solution (VCS): When you use a drug copay card, Specialty prescription drugs may be subject to a new plan benefit cost share. This new cost share will not impact you or the price you pay.	Yes	
Rx Savings Solutions A team of pharmacists and pharmacy technician will help you make sure you're getting the best possible pricing for your medicines. Member support is available Monday – Friday, 7 a.m. to 7 p.m. CST.	Register online at MyBlueKC.com and stay up-to-date on cost saving opportunities. Email: info@rxsavingsllc.com PH: 1-800-268-4476	
6. Plan Benefits – Pharmacy		
	In-Network	Out-of-Network
Retail Pharmacy (Short-term supply: Up to 34 Days)	RxPremier: \$15 Copay/Fill, no Deductible	Not covered

Drug Tier 1: Generic / Generic Specialty		
Drug Tier 2: Preferred / Preferred Specialty	RxPremier: \$50 Copay/Fill, no Deductible	Not covered
Drug Tier 3: Non-Preferred / Non-Preferred Specialty	RxPremier: Deductible, then no charge	Not covered
Retail Pharmacy (Long-term supply: Between 35-102 Days) Drug Tier 1: Generic / Generic Specialty	RxPremier: \$37.50 Copay/Fill, no Deductible	Not covered
Drug Tier 2: Preferred / Preferred Specialty	RxPremier: \$125 Copay/Fill, no Deductible	Not covered
Drug Tier 3: Non-Preferred / Non-Preferred Specialty	RxPremier: Deductible, then no charge	Not covered
Mail Order Pharmacy (Mail Order supply: Between 35-102 Days) Drug Tier 1: Generic	\$15 Copay/Fill, no Deductible	Not covered
Drug Tier 2: Preferred	\$125 Copay/Fill, no Deductible	Not covered
Drug Tier 3: Non-Preferred	Deductible, then no charge	Not covered
Infertility Drugs Retail (Short-term supply) Drug Tier 1: Generic / Generic Specialty	RxPremier: \$15 Copay/Fill, then 50% Coinsurance, no Deductible	Not covered
Drug Tier 2: Preferred / Preferred Specialty	RxPremier: \$50 Copay/Fill, then 50% Coinsurance, no Deductible	Not covered
Drug Tier 3: Non-Preferred / Non-Preferred Specialty	RxPremier: Deductible, then no charge	Not covered
Infertility Drugs Retail (Long-term supply) Drug Tier 1: Generic / Generic Specialty	RxPremier: \$37.50 Copay/Fill, then 50% Coinsurance, no Deductible	Not covered
Drug Tier 2: Preferred / Preferred Specialty	RxPremier: \$125 Copay/Fill, then 50% Coinsurance, no Deductible	Not covered
Drug Tier 3: Non-Preferred / Non-Preferred Specialty	RxPremier: Deductible, then no charge	Not covered
Infertility Drugs Mail Order Pharmacy Drug Tier 1: Generic / Generic Specialty	\$15 Copay/Fill, then 50% Coinsurance, no Deductible	Not covered
Drug Tier 2: Preferred / Preferred Specialty	\$125 Copay/Fill, then 50% Coinsurance, no Deductible	Not covered
Drug Tier 3: Non-Preferred / Non-Preferred Specialty	Deductible, then no charge	Not covered
Impotency Drugs Retail (Short-term supply) Drug Tier 1: Generic / Generic Specialty	RxPremier: \$15 Copay/Fill, then 50% Coinsurance, no Deductible	Not covered
Drug Tier 2: Preferred / Preferred Specialty	RxPremier: \$50 Copay/Fill, then 50% Coinsurance, no Deductible	Not covered
	RxPremier: Deductible, then no charge	Not covered

Drug Tier 3: Non-Preferred / Non-Preferred Specialty		
Impotency Drugs Retail (Long-term supply) Drug Tier 1: Generic / Generic Specialty	RxPremier: \$37.50 Copay/Fill, then 50% Coinsurance, no Deductible	Not covered
Drug Tier 2: Preferred / Preferred Specialty	RxPremier: \$125 Copay/Fill, then 50% Coinsurance, no Deductible	Not covered
Drug Tier 3: Non-Preferred / Non-Preferred Specialty	RxPremier: Deductible, then no charge	Not covered
Impotency Drugs Mail Order Pharmacy Drug Tier 1: Generic / Generic Specialty	\$15 Copay/Fill, then 50% Coinsurance, no Deductible	Not covered
Drug Tier 2: Preferred / Preferred Specialty	\$125 Copay/Fill, then 50% Coinsurance, no Deductible	Not covered
Drug Tier 3: Non-Preferred / Non-Preferred Specialty	Deductible, then no charge	Not covered
Weight Loss Drugs	Not covered	Not covered
Abortion Drugs	Not covered	Not covered

This page intentionally left blank



Kansas City

Plan Information	
Group Name:	Unified School District No. 229, Johnson County, State of Kansas
Plan Name:	BlueSelect Plus - SPIRA BlueSaver - PPO Plan
Group Number:	14274000
State:	Kansas
Effective Date:	01/01/2026
Important Notes:	
For Internal Use Only:	Package: 2524580637 XREF: CG7F Medical: 2344030250 Rx: 2525220265
1. General Plan Information	
Benefit Period	Calendar Year
Funding	Cost Plus
Grandfathered Status	Non-Grandfathered
Product Family	PPO
Consumer-Driven Health Plan (CDHP)	HSA
Spira Care Plan?	Yes No charge (after deductible) for services received from a designated Spira Care Center Provider. Treatment of work-related injury or illness is not covered under your Blue Cross and Blue Shield of Kansas City health benefit plan. Treatment of work-related injuries and illnesses is typically provided through your workers' compensation program. The Spira Care clinics are not participating providers under workers' compensation programs. Please reference your workers' compensation policies and procedures to direct your employees appropriately for work-related injuries.
Religious Employer?	N/A
Classification of Eligible Employees	In accordance with group HR policy
Eligibility	
Minimum Participation Rate	Not Applicable
Enrollment Change Threshold	Not Applicable
Minimum Employee Only Contribution	Not Applicable
Minimum Overall Contribution	Not Applicable
COBRA Billing	Employer
Are Domestic Partners Covered?	No
Are Spouses Covered?	Yes
Are Same Sex Spouses Covered?	Yes
Insurance Coverage Creditable (Medicare Part D)	Yes
Clinical Solutions	
Oncology Utilization Management	Yes
Oncology Care Management	Yes
Musculoskeletal (MSK) Utilization Management	Yes
Cardiac Utilization Management	Yes

Blue Connect	Blue Connect Tier Level : Advanced Support Blue Connect PEPM Rate \$2 Connect PEPM Rate \$2 Active Employees? : Yes Retirees Eligible? : Yes COBRA Employees Eligible? : Yes	
Smart Shopper	Smart Shopper Included	
2. Network		
Local Medical Network	BlueSelect Plus Services rendered at Out-of-Network providers are subject to Out-of-Network allowables as stated in your contract, and balance billing may occur.	
Out-of-Area Medical Network	BlueCard PPO/EPO	
Pharmacy	See Pharmacy (Sections 5 & 6)	
3. Cost Sharing		
Medical Deductible - Calendar Year, Embedded All INN & OON Cross Accum	In-Network	Out-of-Network
Individual	\$3,400	\$6,800
Family	\$6,800	\$13,600
Pharmacy Deductible	Combined with Medical	
Medical Coinsurance	In-Network	Out-of-Network
Member Pays	20%	50%
Plan Pays	80%	50%
Out-of-Pocket Limit - Calendar Year, Embedded All INN & OON Cross Accum The Out-of-Pocket limit includes all Deductibles, Coinsurance, and Copayments a member pays during the Benefit Period.	In-Network	Out-of-Network
Individual	\$5,000	\$13,500
Family	\$12,500	\$27,000
Pharmacy Out-of-Pocket Limit	Combined with Medical	
Annual First Dollar Coverage	Does not apply	Does not apply
Annual Maximum	Does not apply	Does not apply
Lifetime Maximum	Does not apply	Does not apply
4. Benefits		
Professional Services	In-Network	Out-of-Network
Primary Care Physician Office Visit - An internist, family practitioner, general practitioner, or pediatrician.	20% Coinsurance after Deductible	50% Coinsurance after Deductible
Total Care Primary Care Physician Office Visit	Does not apply	Not applicable
Specialist Physician Office Visit - Doctors of Medicine (MD), Doctors of Osteopathy (DO), except Primary Care Physicians, and other medical practitioners such as optometrists, psychologists and chiropractors.	20% Coinsurance after Deductible	50% Coinsurance after Deductible
Urgent Care Office Visit	20% Coinsurance after Deductible	50% Coinsurance after Deductible
Total Care Urgent Care Office Visit	Does not apply	Not applicable
Blue KC Virtual Care - Office Visit Virtual care provided by Blue KC virtual care partner(s).	20% Coinsurance after Deductible	Not applicable
Blue KC Virtual Care - Behavioral Health Therapy	20% Coinsurance after Deductible	Not applicable

Virtual care provided by Blue KC virtual care partner(s).		
Telehealth - Telehealth Providers other than Blue KC Virtual Care - Office Visit - Primary Care	20% Coinsurance after Deductible	50% Coinsurance after Deductible
Telehealth - Telehealth Providers other than Blue KC Virtual Care - Office Visit - Behavioral Health	20% Coinsurance after Deductible	50% Coinsurance after Deductible
Telehealth - Telehealth Providers other than Blue KC Virtual Care - Behavioral Health Therapy	20% Coinsurance after Deductible	50% Coinsurance after Deductible
Designated Health Clinic	Does not apply	Not applicable
Other Benefits (in alphabetical order)	In-Network	Out-of-Network
ABA Services	Subject to Applicable Cost Shares	Subject to Applicable Cost Shares
Abortion	Not covered	Not covered
Acupuncture	Not covered	Not covered
Allergy Testing	20% Coinsurance after Deductible	50% Coinsurance after Deductible
Allergy Treatment	20% Coinsurance after Deductible	50% Coinsurance after Deductible
Ambulance - Air	20% Coinsurance after Deductible	20% Coinsurance after In-Network Deductible
Ambulance - Ground Ground Ambulance Allowable Option: 150% of Medicare	20% Coinsurance after Deductible	20% Coinsurance after In-Network Deductible
Assisted Reproductive Services	Not covered	Not covered
Autism-Related Services No Limits	Subject to Applicable Cost Shares	Subject to Applicable Cost Shares
Bariatric Services	Not covered	Not covered
Blue Distinction Specialty Care Facility Services No Limits	Not Applicable	Not Applicable
Chiropractic Office Visit	20% Coinsurance after Deductible	50% Coinsurance after Deductible
Dental Anesthesia Maximum age limit of 5 Years	Missouri/Kansas Default	Missouri/Kansas Default
Diabetic Equipment and Supplies Prior Authorization Policy Applies	20% Coinsurance after Deductible	50% Coinsurance after Deductible
Diabetic Footwear	20% Coinsurance after Deductible	50% Coinsurance after Deductible
Diabetic Pump	Covered as Durable Medical Equipment (DME)	Covered as Durable Medical Equipment (DME)
Diabetic Self Management Education/Training (DSMT)	No member cost share	50% Coinsurance after Deductible
Durable Medical Equipment (DME) Prior Authorization Policy Applies No Limits	20% Coinsurance after Deductible	50% Coinsurance after Deductible
Elective Male Sterilization	Deductible, then no charge	50% Coinsurance after Deductible
Emergency Services	20% Coinsurance after Deductible	20% Coinsurance after In-Network Deductible
Food and Food Products for PKU Maximum benefit of \$5,000/Calendar Year for In-Network and Out-of-Network	Covered	Covered
Foot Orthotics	Not covered	Not covered
Gender Dysphoria-Related Services Prior Authorization Policy Applies Gender Dysphoria Cost Shares Apply to Cosmetic Services: No Gender Dysphoria Cost Shares Apply to Non-Surgical Services: Yes	Subject to Applicable Cost Shares	Subject to Applicable Cost Shares

Gender Dysphoria Cost Shares Apply to Reassignment Surgery: Yes		
Hearing Aids	Not covered	Not covered
High Tech Radiology (MRI, MRA, PET, CT) Prior Authorization Policy Applies	20% Coinsurance after Deductible	50% Coinsurance after Deductible
Home Health Care Prior Authorization Policy Applies Maximum benefit of 60 Visit(s)/Calendar Year for In-Network and Out-of-Network	20% Coinsurance after Deductible	50% Coinsurance after Deductible
Home Hospice	20% Coinsurance after Deductible	50% Coinsurance after Deductible
Immunizations - Not Routine Preventive	Not covered	Not covered
Infertility and Impotency Diagnosis & Treatment Infertility and impotency treatment: No limits Medical Dollar limitations include pharmacy: Yes	20% Coinsurance after Deductible	50% Coinsurance after Deductible
Inpatient Hospice Prior Authorization Policy Applies Maximum benefit of 14 Day(s)/Lifetime for In-Network and Out-of-Network	20% Coinsurance after Deductible	50% Coinsurance after Deductible
Inpatient Hospital Facility (including Physician Services billed by Facility) Prior Authorization Policy Applies	20% Coinsurance after Deductible	50% Coinsurance after Deductible
Inpatient Physician Services	20% Coinsurance after Deductible	50% Coinsurance after Deductible
Labs Performed in Office / Independent Lab	20% Coinsurance after Deductible	50% Coinsurance after Deductible
Maternity Dependent Daughters Maternity Covered?: No	Covered	Covered
Mental Health and Substance Abuse Services - Inpatient Hospital Facility (including Physician Services billed by Facility) Prior Authorization Policy Applies	20% Coinsurance after Deductible	50% Coinsurance after Deductible
Mental Health and Substance Abuse Services - Inpatient Physician Services	20% Coinsurance after Deductible	50% Coinsurance after Deductible
Mental Health and Substance Abuse Services - Office Visit	20% Coinsurance after Deductible	50% Coinsurance after Deductible
Mental Health and Substance Abuse Services - Outpatient Therapy in a Facility	20% Coinsurance after Deductible	50% Coinsurance after Deductible
Mental Health and Substance Abuse Services - Outpatient Therapy in a Provider's Office	20% Coinsurance after Deductible	50% Coinsurance after Deductible
Nutritional Counseling No Limits Nutritional Counseling Services Covered: Includes all Dx	Subject to Applicable Cost Shares	Subject to Applicable Cost Shares
Organ Transplant Services Prior Authorization Policy Applies	Subject to Applicable Cost Shares Blue Distinction Specialty Care Facility Services: Not applicable	Subject to Applicable Cost Shares
Organ Transplant Travel Expenses	Not covered	Not covered
Other Services Performed in Office	20% Coinsurance after Deductible	50% Coinsurance after Deductible

Outpatient Physician Services	20% Coinsurance after Deductible	50% Coinsurance after Deductible
Outpatient Surgery Prior Authorization Policy Applies	20% Coinsurance after Deductible	50% Coinsurance after Deductible
Outpatient Therapy - Cardiac Therapy No Limits	20% Coinsurance after Deductible	50% Coinsurance after Deductible
Outpatient Therapy - Cognitive Therapy	20% Coinsurance after Deductible	50% Coinsurance after Deductible
Outpatient Therapy - Hearing Therapy in a Facility Combined with Hearing Therapy in a Provider's Office Limits	20% Coinsurance after Deductible	50% Coinsurance after Deductible
Outpatient Therapy - Hearing Therapy in a Provider's Office Combined with Speech Therapy Limits	20% Coinsurance after Deductible	50% Coinsurance after Deductible
Outpatient Therapy - Occupational Therapy in a Facility Combined with Occupational Therapy in a Provider's Office Limits	20% Coinsurance after Deductible	50% Coinsurance after Deductible
Outpatient Therapy - Occupational Therapy in a Provider's Office Combined with Physical Therapy Limits	20% Coinsurance after Deductible	50% Coinsurance after Deductible
Outpatient Therapy - Physical Therapy in a Facility Combined with Physical Therapy in a Provider's Office Limits	20% Coinsurance after Deductible	50% Coinsurance after Deductible
Outpatient Therapy - Physical Therapy in a Provider's Office Maximum benefit of 60 Visit(s)/Calendar Year for In-Network and Out-of-Network	20% Coinsurance after Deductible	50% Coinsurance after Deductible
Outpatient Therapy - Pulmonary Therapy No Limits	20% Coinsurance after Deductible	50% Coinsurance after Deductible
Outpatient Therapy - Skeletal Manipulation Prior Authorization Policy Applies Out-of-Network Combined with Physical Therapy Limits	20% Coinsurance after Deductible	50% Coinsurance after Deductible
Outpatient Therapy - Speech Therapy in a Facility Combined with Speech Therapy in a Provider's Office Limits	20% Coinsurance after Deductible	50% Coinsurance after Deductible
Outpatient Therapy - Speech Therapy in a Provider's Office Maximum benefit of 20 Visit(s)/Calendar Year for In-Network and Out-of-Network	20% Coinsurance after Deductible	50% Coinsurance after Deductible
Private Duty Nursing Combined with Home Health Care Limits	20% Coinsurance after Deductible	50% Coinsurance after Deductible
Routine Preventive Care Diabetes Prevention Program (DPP): Covered Preventive Schedule: PPACA+ (Women's Preventive)	No member cost share	50% Coinsurance after Deductible
Skilled Nursing Facility (SNF) Prior Authorization Policy Applies Maximum benefit of 30 Day(s)/Calendar Year for In-Network and Out-of-Network	20% Coinsurance after Deductible	50% Coinsurance after Deductible
Sports Physicals by a Physician	Not covered	Not covered
Vision Exam-Routine	Not covered	Not covered

Vision Hardware	Not covered	Not covered
Weight Management - Wondr Health	No member cost share	Not Applicable
Wigs	Not covered	Not covered
X-Rays and Radiology	20% Coinsurance after Deductible	50% Coinsurance after Deductible
5. General Pharmacy Information		
Pharmacy Network(s)	Network 1: RxPremier	
Prescription Drug List Learn more about the drugs covered by your plan, drug category/tier, prior authorization and step therapy by reviewing your prescription drug list on MyBlueKC.com	Premium Formulary	
Outpatient Prescription Drug Deductible You must pay all the costs up to the Deductible amount before this plan begins to pay for covered services.	In-Network Combined with Medical Deductible	Out-of-Network Combined with Medical Deductible
Outpatient Prescription Drug Out-of-Pocket Limits The Out-of-Pocket Limit is the most you could pay during the Calendar Year for your share of the cost of covered services.	In-Network Combined with Medical Out-of-Pocket	Out-of-Network Combined with Medical Out-of-Pocket
Infertility/Impotency Drugs	No limit Combined Medical/Pharmacy limit	
Biosimilar Product Penalty	Applies	
Maintenance Medication Program	Not applicable	
Generics Program	Not Applicable	
Copay Credit Accumulator Adjustment (CCAA): Specialty drug copay card dollars will not be included in your deductible and/or out-of-pocket limits. Only your true out-of-pocket costs will be applied to your deductible and/or out-of-pocket totals.	Yes	
Variable Copay Solution (VCS): When you use a drug copay card, Specialty prescription drugs may be subject to a new plan benefit cost share. This new cost share will not impact you or the price you pay.	No	
Rx Savings Solutions A team of pharmacists and pharmacy technician will help you make sure you're getting the best possible pricing for your medicines. Member support is available Monday – Friday, 7 a.m. to 7 p.m. CST.	Register online at MyBlueKC.com and stay up-to-date on cost saving opportunities. Email: info@rxsavingsllc.com PH: 1-800-268-4476	
6. Plan Benefits – Pharmacy		
	In-Network	Out-of-Network
Retail Pharmacy (Short-term supply: Up to 34 Days) Drug Tier 1: Generic / Generic Specialty	RxPremier: Deductible, then 20% Coinsurance	Deductible, then \$15 Copay/Fill, then 50% Coinsurance

Drug Tier 2: Preferred / Preferred Specialty	RxPremier: Deductible, then 20% Coinsurance	Deductible, then \$50 Copay/Fill, then 50% Coinsurance
Drug Tier 3: Non-Preferred / Non-Preferred Specialty	RxPremier: Deductible, then 20% Coinsurance	Deductible, then 50% Coinsurance
Retail Pharmacy (Long-term supply: Between 35-102 Days) Drug Tier 1: Generic / Generic Specialty	RxPremier: Deductible, then 20% Coinsurance	Deductible, then \$37.50 Copay/Fill, then 50% Coinsurance
Drug Tier 2: Preferred / Preferred Specialty	RxPremier: Deductible, then 20% Coinsurance	Deductible, then \$125 Copay/Fill, then 50% Coinsurance
Drug Tier 3: Non-Preferred / Non-Preferred Specialty	RxPremier: Deductible, then 20% Coinsurance	Deductible, then 50% Coinsurance
Mail Order Pharmacy (Mail Order supply: Between 35-102 Days) Drug Tier 1: Generic	Deductible, then 20% Coinsurance	Deductible, then \$15 Copay/Fill, then 50% Coinsurance
Drug Tier 2: Preferred	Deductible, then 20% Coinsurance	Deductible, then \$125 Copay/Fill, then 50% Coinsurance
Drug Tier 3: Non-Preferred	Deductible, then 20% Coinsurance	Deductible, then 50% Coinsurance
Preventive Drugs Preventive Drugs List: All Preventive Retail (Short-Term) Drug Tier 1: Generic / Generic Specialty	RxPremier: Deductible, then 20% Coinsurance	Deductible, then \$15 Copay/Fill, then 50% Coinsurance
Retail (Short-Term) Drug Tier 2: Preferred / Preferred Specialty	RxPremier: Deductible, then 20% Coinsurance	Deductible, then \$50 Copay/Fill, then 50% Coinsurance
Retail (Short-Term) Drug Tier 3: Non-Preferred / Non-Preferred Specialty	RxPremier: Deductible, then 20% Coinsurance	Deductible, then 50% Coinsurance
Retail (Long-Term) Drug Tier 1: Generic / Generic Specialty	RxPremier: Deductible, then 20% Coinsurance	Deductible, then \$37.50 Copay/Fill, then 50% Coinsurance
Retail (Long-Term) Drug Tier 2: Preferred / Preferred Specialty	RxPremier: Deductible, then 20% Coinsurance	Deductible, then \$125 Copay/Fill, then 50% Coinsurance
Retail (Long-Term) Drug Tier 3: Non-Preferred / Non-Preferred Specialty	RxPremier: Deductible, then 20% Coinsurance	Deductible, then 50% Coinsurance
Mail Order Drug Tier 1: Generic / Generic Specialty	Deductible, then 20% Coinsurance	Deductible, then \$15 Copay/Fill, then 50% Coinsurance
Mail Order Drug Tier 2: Preferred / Preferred Specialty	Deductible, then 20% Coinsurance	Deductible, then \$125 Copay/Fill, then 50% Coinsurance
Mail Order Drug Tier 3: Non-Preferred / Non-Preferred Specialty	Deductible, then 20% Coinsurance	Deductible, then 50% Coinsurance
Infertility Drugs Retail (Short-term supply) Drug Tier 1: Generic / Generic Specialty	RxPremier: Deductible, then 50% Coinsurance	Deductible, then \$15 Copay/Fill, then 50% Coinsurance
Drug Tier 2: Preferred / Preferred Specialty	RxPremier: Deductible, then 50% Coinsurance	Deductible, then \$50 Copay/Fill, then 50% Coinsurance
Drug Tier 3: Non-Preferred / Non-Preferred Specialty	RxPremier: Deductible, then 50% Coinsurance	Deductible, then 50% Coinsurance
	RxPremier: Deductible, then 50% Coinsurance	Deductible, then \$37.50 Copay/Fill, then 50% Coinsurance

Infertility Drugs Retail (Long-term supply) Drug Tier 1: Generic / Generic Specialty		
Drug Tier 2: Preferred / Preferred Specialty	RxPremier: Deductible, then 50% Coinsurance	Deductible, then \$125 Copay/Fill, then 50% Coinsurance
Drug Tier 3: Non-Preferred / Non-Preferred Specialty	RxPremier: Deductible, then 50% Coinsurance	Deductible, then 50% Coinsurance
Infertility Drugs Mail Order Pharmacy Drug Tier 1: Generic / Generic Specialty	Deductible, then 50% Coinsurance	Deductible, then \$15 Copay/Fill, then 50% Coinsurance
Drug Tier 2: Preferred / Preferred Specialty	Deductible, then 50% Coinsurance	Deductible, then \$125 Copay/Fill, then 50% Coinsurance
Drug Tier 3: Non-Preferred / Non-Preferred Specialty	Deductible, then 50% Coinsurance	Deductible, then 50% Coinsurance
Impotency Drugs Retail (Short-term supply) Drug Tier 1: Generic / Generic Specialty	RxPremier: Deductible, then 50% Coinsurance	Deductible, then \$15 Copay/Fill, then 50% Coinsurance
Drug Tier 2: Preferred / Preferred Specialty	RxPremier: Deductible, then 50% Coinsurance	Deductible, then \$50 Copay/Fill, then 50% Coinsurance
Drug Tier 3: Non-Preferred / Non-Preferred Specialty	RxPremier: Deductible, then 50% Coinsurance	Deductible, then 50% Coinsurance
Impotency Drugs Retail (Long-term supply) Drug Tier 1: Generic / Generic Specialty	RxPremier: Deductible, then 50% Coinsurance	Deductible, then \$37.50 Copay/Fill, then 50% Coinsurance
Drug Tier 2: Preferred / Preferred Specialty	RxPremier: Deductible, then 50% Coinsurance	Deductible, then \$125 Copay/Fill, then 50% Coinsurance
Drug Tier 3: Non-Preferred / Non-Preferred Specialty	RxPremier: Deductible, then 50% Coinsurance	Deductible, then 50% Coinsurance
Impotency Drugs Mail Order Pharmacy Drug Tier 1: Generic / Generic Specialty	Deductible, then 50% Coinsurance	Deductible, then \$15 Copay/Fill, then 50% Coinsurance
Drug Tier 2: Preferred / Preferred Specialty	Deductible, then 50% Coinsurance	Deductible, then \$125 Copay/Fill, then 50% Coinsurance
Drug Tier 3: Non-Preferred / Non-Preferred Specialty	Deductible, then 50% Coinsurance	Deductible, then 50% Coinsurance
Weight Loss Drugs	Not covered	Not covered
Abortion Drugs	Not covered	Not covered

This page intentionally left blank

Blue Cross and Blue Shield of Kansas City

COST-PLUS ADDENDUM

This Cost-Plus Addendum (“Addendum”) amends and is incorporated into and made a part of the Group Contract(s) entered into by and between Blue Cross and Blue Shield of Kansas City, on behalf of itself and its subsidiary, Good Health HMO, Inc., d/b/a Blue-Care, if applicable (collectively, “BCBSKC”) and Unified School District No. 229, Johnson County, State of Kansas (“Employer”). This Addendum shall be effective January 1, 2026 (the “Effective Date”).

WHEREAS, the parties have entered into the Group Contract(s) numbered 14274000 and the associated Health and, if applicable, Dental Benefit Certificate(s) (collectively, the “Group Contract(s)”), pursuant to which BCBSKC has agreed to arrange for the provision of certain health care services and/or dental care to Employer’s eligible Employees and their covered Dependents in accordance with the terms, conditions, limitations and exclusions specified in the Group Contract(s);

WHEREAS, the parties desire to implement an alternative funding arrangement for the Group Contract(s), as set forth herein; and

WHEREAS, this Addendum, while implementing an alternative funding arrangement, does not alter any terms or conditions of the benefits covered under the Group Contract(s).

NOW, THEREFORE, in consideration of the foregoing, the mutual promises and agreements contained herein, and other good and valuable consideration, the receipt and sufficiency of which are hereby acknowledged, the parties hereby agree as follows:

Article 1 **Employer’s Obligations**

- 1.1 **Funding under Group Contracts.** Employer agrees that the funding for coverage under the Group Contract(s) shall be determined as set forth in this Addendum.
- 1.2 **Fixed Premium.** Employer shall pay BCBSKC, on a monthly basis, the Fixed Premium in accordance with Article 3.2.
- 1.3 **Employer’s Claims Obligations.** In order to fulfill the Employer’s total financial obligations under the terms of this Addendum, the Employer shall make payments to BCBSKC as set forth herein and in accordance with Article 3.1. For each month that this Addendum is in effect, Employer shall pay to BCBSKC an amount set forth in (a) and (b) below:
 - (a) the lesser of:
 - i. the Cumulative Paid Claims; or
 - ii. the Cumulative Monthly Claims Limit.

LESS

- (b) the Cumulative Prior Payment Amount.

Example:

	January	February	March	April
Paid Claims	70	80	110	90
Cumulative Paid Claims	70	150	260	350
Monthly Claims Limit	100	100	100	100
Cumulative Monthly Claims Limit	100	200	300	400
Cumulative Prior Payment Amount	0	70	150	260
Actual Payment Owed	70	80	110	90

Notwithstanding the foregoing: (1) Paid Claims in excess of the Individual Pooling Limit for any Covered Person will not be counted as Paid Claims for the purposes of the calculation set forth above; and (2) the Cumulative Monthly Claims Limit for the full Contract Period shall not be less than the Minimum Annual Claims Limit set forth in Exhibit A (Cost Plus Provisions).

1.4 Statutory Assessments. To the extent BCBSKC is required to pay any Statutory Assessments, Employer will pay BCBSKC an amount equal to the Statutory Assessments based upon BCBSKC’s determination of such amounts. BCBSKC shall bill the Employer the applicable portion of these Statutory Assessments on the Monthly Settlement Report, and the Employer shall pay such Statutory Assessments in accordance with Article 3.

1.5 Collateral. Upon BCBSKC’s request, Employer shall procure a letter of credit (in such form as is reasonably acceptable to BCBSKC) from a financial institution reasonably acceptable to BCBSKC that evidences a commitment by the financial institution of funds payable to BCBSKC upon demand (without any further or additional action or authorization by Employer). Employer shall maintain such letter of credit until the end of the Runout Period. Alternatively, upon BCBSKC’s request, Employer shall deliver to BCBSKC an amount reasonably requested by BCBSKC as collateral (“Collateral”) for Employer’s obligations under this Agreement. In the event Employer fails to pay amounts due to BCBSKC hereunder, BCBSKC may use as much or all of the Collateral as is needed to satisfy Employer’s obligations. Any unused Collateral will be returned to Employer at the end of the Runout Period.

Article 2
BCBSKC Rights and Obligations

2.1 Benefit Determinations. For the purpose of this Addendum, BCBSKC shall have the right to determine the amount of Benefits, if any, payable for any Covered Person. Employer delegates to BCBSKC discretionary authority to construe, interpret and apply the Plan for purposes of processing claims and appeals. BCBSKC, as claims fiduciary, has the full, final, binding and exclusive discretion to construe, interpret and apply the terms of the Plan as may be necessary in order to process claims and make determinations on appeal of claims. BCBSKC shall determine the extent of the benefits (if any) to which any Participant is entitled under the Plan. Decisions by BCBSKC shall be complete, final and binding on all parties. Such determination shall be on the same basis as would be applicable under the Group Contract(s) in the absence of this Addendum. In the event of legal action against BCBSKC, by or on behalf of a Covered Person for Benefits under the Group Contract(s) with respect to a denied claim,

BCBSKC, at its own expense, shall undertake the defense of such action and shall pay any judgment rendered therein. BCBSKC shall have the right to settle any such action. The Employer shall reimburse BCBSKC for the portion of any such judgment or settlement which is for a Paid Claim under the Group Contract(s), and such Paid Claim shall be administered in accordance with the terms of this Addendum, including Articles 1 and 3.

Article 3

Payment Due Dates, Grace Periods and Payment Changes

3.1 **Monthly Settlement.** Monthly payments for Paid Claims, Access Fees, Statutory Assessments and related charges, as indicated on the Monthly Settlement Report, are due and payable by the Employer within 31 calendar days following delivery to Employer by BCBSKC of the Monthly Settlement Report. The Employer shall have no grace period for such monthly payment.

3.2 **Fixed Premium.** The Fixed Premium is due and payable by the Employer the first day of each month; provided, that any Statutory Assessments and Access Fees will be due and payable by Employer with the Monthly Settlement as set forth in Article 3.1. The Employer shall have a grace period of 31 calendar days for such monthly Fixed Premium.

3.3 **Changes in Employer's Obligation.** BCBSKC reserves the right to change any and all fees, charges and factors upon a 31 calendar day written notice prior to the end of a Contract Period, to be effective for the following Contract Period.

3.4 **Late Payment Charge.** BCBSKC reserves the right to charge a late payment fee of \$0.00 in each instance in which Employer fails to timely pay any amount due to BCBSKC in accordance with this Article 3.

Article 4

Amendments

4.1 **General.** Except as provided in Article 3.3, BCBSKC may amend any other term or condition of this Addendum upon 60 calendar days written notice to conform to statutes of the state in which this Addendum is issued for delivery.

4.2 **Notice.** Notice of an amendment may be in the form of a new Addendum, a rider, or an amendment to this Addendum or otherwise as BCBSKC may elect.

Article 5
Termination

5.1 Term. The term of this Addendum shall begin on the Effective Date and shall continue until terminated as set forth in this Article 5.

5.2 Termination by Either Party. This Addendum may be terminated by BCBSKC or the Employer provided such party gives the other party written notice of its election to terminate the Addendum at least 30 calendar days prior to the end of the then current Contract Period. This Addendum and the underlying Group Contract(s) shall automatically terminate on the date of termination of the Group Contract(s).

(a) Early Termination. If Employer causes the termination of this Addendum prior to the expiration of the then current Contract Period, Employer acknowledges that such Early Termination will cause damages to BCBSKC and agrees to compensate BCBSKC for such damages by payment of an early termination fee ("Early Termination Fee"). Employer agrees that it shall pay, within thirty (30) days of any notice of Early Termination, the Early Termination Fee of 20% of the then current total aggregate monthly Fixed Cost Fees plus Access Fees multiplied by the number months remaining in the then current Contract Period as of the effective date of the Early Termination.

5.3 Termination Due to Material Default. Except as provided in Article 5.4 below, either party may terminate this Addendum for cause upon written notice if the other party materially defaults in the performance of a provision of this Addendum and such default continues for a period of 60 calendar days after written notice to the defaulting party from the aggrieved party stating the specific default.

5.4 Termination Due to Non-Payment. Notwithstanding anything to the contrary herein, if Employer fails to pay BCBSKC in accordance with Article 3, this Addendum and the underlying Group Contract(s) may be terminated by BCBSKC, effective retroactively to the last day of the month in which all amounts owed to BCBSKC for such month were paid by the Employer.

5.5 Runout.

(a) Runout Claims and Services. Upon termination of this Addendum, and except in the event of Employer's material breach of this Addendum (including Employer's non-payment), BCBSKC shall provide Runout Services for Runout Claims.

(b) Runout Services Fee and Claims Obligation. Monthly payments for Runout Claims and the Runout Services Fee are due and payable by Employer for each month during the Runout Period within 31 calendar days following delivery to Employer by BCBSKC of the Monthly Settlement Report. The Employer shall have no grace period for such payments. Unless Employer purchases Terminal Liability Coverage as set forth in Article 5.6 below, Employer shall have the total obligation for Runout Claims.

(c) Statutory Assessments for Runout Claims and/or Runout Services. To the extent that any Statutory Assessments apply to Employer's payment obligations under Article 5.5 and/or 5.6, as determined by BCBSKC in its sole and reasonable discretion, then Employer shall pay to BCBSKC an amount equal to such Statutory Assessments.

5.6 Terminal Liability Coverage. Employer may choose to purchase, at the time of execution of this Addendum, Terminal Liability Coverage; provided, that there is no Individual Pooling Limit with respect to Runout Claims. If Employer purchases Terminal Liability Coverage, the following shall apply:

(a) Terminal Liability Coverage Charges. Terminal Liability Coverage Charges will be included with the Pooling Charges and paid by the Employer in accordance with Article 3.2.

(b) Terminal Liability Factors. The Employer's obligation for Runout Claims is limited to the amounts set forth in the "Terminal Liability Factors" section of Exhibit B (Rate Exhibits) for each Coverage Class and Product Type combination, multiplied by the number of such Coverage Class and Product Type combinations, based on the greater of:

1. enrollment during the last month of the final Contract Period; or
2. the average enrollment during the last three (3) months of the final Contract Period.

5.7 Late Payment. BCBSKC reserves the right to charge a late payment fee of \$0.00 in each instance in which Employer fails to timely pay any amount due to BCBSKC in accordance with this Article 5.

Article 6 General Provisions

6.1 Modification of Group Contracts. The provisions of the Group Contract(s) are amended to the extent necessary to be consistent with the provisions set forth in this Addendum and to that extent the provisions of this Addendum shall govern notwithstanding anything in the Group Contract(s) to the contrary.

6.2 Waiver. Neither the failure nor any delay by either party to exercise any right, power or privilege hereunder shall operate as a waiver thereof, nor shall any single or partial exercise of any such right, power or privilege preclude any other or further exercise thereof, or the exercise of any other right, power or privilege. In the event that a party does waive any breach of any provision of this Addendum, such waiver shall not be deemed or construed as a continuing waiver of any breach of the same or different provision.

6.3 Assignment. BCBSKC shall have the right to assign or delegate its duties and obligations under this Addendum to its affiliated companies. Any other assignment of this Addendum or, of any rights contained in this Addendum, by either party, will be void and of no force or effect, unless agreed upon in writing by the parties.

6.4 BlueCard Fees. Employer understands and agrees: (a) to pay certain fees and compensation to BCBSKC which BCBSKC is obligated under BlueCard to pay to other Blue Cross and/or Blue Shield licensees ("Licensees"), to the Blue Cross and Blue Shield Association, or to the BlueCard vendors; and (b) that fees and compensation under BlueCard may be revised from time to time without Employer's prior approval in accordance with the standard procedures for revising fees and compensation under BlueCard. Some of these fees and compensation are charged each time a claim is processed through BlueCard and include, but are not limited to, access fees, administrative expense allowance fees, Central

Financial Agency Fees, and ITS Transaction Fees. Other fees include, but are not limited to, an 800 number fee and a fee for provider directories. All of the previously described fees, together, are “BlueCard Fees.” Employer may contact BCBSKC if Employer would like an updated listing of the BlueCard fees. BlueCard fees are included in the Fixed Costs Fees and are guaranteed for the term of this Addendum.

6.5 BlueCard Recoveries. Under BlueCard, recoveries from a Licensee or from participating providers of a Licensee can arise in several ways, including, but not limited to, anti-fraud and abuse audits, provider/hospital audits, credit balance audits, utilization review refunds, and unsolicited refunds. In some cases, the Licensee will engage third parties to assist in discovery or collection of recovery amounts. The fees of such a third party are netted against the recovery. Recovery amounts, net of fees, if any, will be applied in accordance with applicable BlueCard policies, which generally require correction on a claim-by-claim or prospective basis. Unless otherwise agreed to by the Licensee, BCBSKC may request adjustments from the Licensee for full provider refunds due to the retroactive cancellation of membership only for one year after the Inter-Licensee financial settlement process date of the original claim. In some cases, recovery of claim payments associated with a retroactive cancellation may not be possible if the recovery conflicts with the Licensee’s state law, provider contracts or jeopardizes its relationship with its providers.

6.6 BCBSKC Recoveries. BCBSKC may pursue recoveries of Paid Claims in accordance with its rules and procedures (including via the use of third parties acting on BCBSKC’s behalf), which may arise in several ways, including but not limited to, anti-fraud and abuse audits, provider/hospital audits, utilization review refunds, and class action settlement, mass tort, or other litigation recoveries from health care providers and manufacturers of health care or other products or services. Any recovery will be credited to the Employer, subject to the terms of this Addendum, as described in 6.6.1; provided, that BCBSKC may charge the Employer a fee of up to 30% of the gross recovery including any third party fees and expenses for such recoveries, which will be netted against any such recovery. The recovery fee may exceed 30% if the applicable recovery vendor’s fee exceeds that percentage. BCBSKC shall have the right to retain any net recovery not exceeding \$500 if 3 years have elapsed since this Addendum terminated. Employer does not possess an independent right to pursue recoveries of Paid Claims.

6.6.1 In the event the BCBSKC obtains, directly or through a third party, recoveries that relate to Paid Claims, the following will apply:

- a. Employer shall first reimburse BCBSKC directly a pro rata portion of such recovery;
- b. Such portion shall not exceed the amount BCBSKC has paid under the Agreement;
- c. Such portion will be net of BCBSKC’s portion of recovery fees;
- d. Allocation of the recovery fees will be based upon the amount related to such recovery that was paid by BCBSKC and Employer; and
- e. Employer will retain or receive the remaining portion of such recovery net of its portion of recovery fees.

6.6.2 Any amounts recovered by BCBSKC shall not apply to and shall not be used to satisfy the Individual Pooling limit.

6.7 Medical Value Payments. Employer acknowledges that BCBSKC may have value-based payment arrangements with providers participating in certain health care delivery programs, including but not limited to patient-centered medical homes, accountable care organizations or episode-based

provider payments. These providers are known as “Total Care” providers. Pursuant to such health care delivery programs, Total Care providers may be eligible for alternative payments, in lieu of or in addition to, traditional fee-for-service reimbursement, including but not limited to, withholds, bonuses, incentive payments, provider credits and member management fees (collectively, “Medical Value Payments”). The amount of Medical Value Payments Total Care providers receive is specific to the Total Care program and/or provider and may or may not be directly related to Employer, any Covered Person, or any other group or individual. Employer acknowledges that Medical Value Payments payable to any one or more Total Care providers (a) will be included in Paid Claims, (b) may include compensation for services that are related to Covered Services, including, but not limited to, coordination of care, and (c) may include compensation in recognition of Total Care provider’s achievement of stated performance objectives, including, but not limited to, quality of care, patient outcomes or cost.

6.8 BCBSKC Prescription Drug Program BCBSKC contracts with a pharmacy benefit manager (“PBM”) for certain prescription drug administrative services, including prescription drug rebate administration and pharmacy network contracting services.

Under the agreement, PBM obtains rebates from drug manufacturers based on the utilization of certain prescription products by Covered Persons, and PBM retains the benefit of the rebate funds prior to disbursement. In addition, pharmaceutical manufacturers may pay administrative fees to PBM in connection with PBM’s services of administering, invoicing, allocating, and/or collecting rebates, and the PBM retains the benefit of such amounts prior to disbursement. PBM may also receive other service fees or discounts from manufacturers as compensation for various services unrelated to rebates or rebate-associated administrative fees.

In addition, BCBSKC and PBM also contract with pharmacies to provide prescription products at discounted rates for BCBSKC members. The discounted rates paid by PBM and BCBSKC to these pharmacies differ among pharmacies within a network, as well as between networks. For pharmacies that contract with the PBM, the amount paid by BCBSKC pays a uniform discount rate to PBM under the BCBSKC contract with the PBM may vary from regardless of the various discount rates PBM pays to the pharmacies. Thus, where the BCBSKC rate exceeds the rate the PBM negotiated with a particular pharmacy, the PBM will realize a positive margin on the applicable prescription. The reverse may also be true, resulting in negative margin for the PBM. In addition, when the PBM receives payment from BCBSKC before payment to a pharmacy is due, the PBM retains the benefit of the use of these funds between these payments. BCBSKC is guaranteed a minimum level of discount whether through the PBM or where BCBSKC directly contracts with network pharmacies, which could result in the amount paid by Employer being more or less than the amount PBM and/or BCBSKC pay to pharmacies.

Employer acknowledges and agrees for itself and its Covered Persons that BCBSKC is not acting as a fiduciary with respect to rebate administration, pharmacy network management, or the prescription drug plan. Employer further acknowledges for itself and its Covered Persons that BCBSKC receives rebates from the PBM and may receive positive margin in connection with the pharmacy network, as well as other financial credits, administrative fees and/or other amounts from network pharmacies, drug manufacturers or the PBM (collectively “Financial Credits”). Employer acknowledges and agrees for itself and its Covered Persons that, except as specifically provided in section 6.8.1 for certain pharmacy carve-in credits, BCBSKC shall retain sole and exclusive right to all Financial Credits, which constitute BCBSKC property (and are not plan assets), and BCBSKC may use such Financial Credits in its sole and absolute discretion, including without limitation to help stabilize BCBSKC’s overall rates and to offset expenses, and BCBSKC does not share Financial Credits with the Employer.

Without limitation to the foregoing, Employer acknowledges and agrees to the following (“Financial Credit Rules”) for itself and its Covered Persons that: (1) Employer and/or Covered Persons shall have no right to receive, claim or possess any beneficial interest in any Financial Credits, except as specifically provided in section 6.8 ; (2) Applicable drug benefit copayments, coinsurance, outpatient prescription drug deductible, deductible and/or maximum allowable benefits (including without limitation Calendar Year Maximum and Lifetime Maximum benefits) shall in no way be adjusted or otherwise affected as a result of any Financial Credits, except as may be required by law; (3) Any deductible and/or coinsurance required for prescription drugs shall be based upon the allowable charge at the pharmacy, and shall not change as a result of any Financial Credits, except as may be required by law; and (4) Amounts paid to pharmacies or any prices charged at pharmacies shall in no way be adjusted or otherwise affected as a result of any Financial Credits.

6.8.1 Pharmacy Carve-In Credits. BCBSKC agrees to provide Employer with pharmacy carve in-credits as provided in this section. The carve-in credit shall be \$55.00 per member per month, and shall be paid on a quarterly basis through a credit against amounts invoiced and due from Employer. The number of members shall be determined from the actual enrollment in the health plans with prescription drug coverage.

BCBSKC has the right, upon notice, to make an equitable adjustment to the carve-in credit amount in the event there is:

- (a) a material change in the conditions or assumptions utilized in providing the carve-in credit;
- (b) a material change in the size or demographics of the Employer’s membership;
- (c) Employer takes an action that has the effect of lowering the amount of Financial Credits available to BCBSKC; or
- (d) A material change in law or the pharmacy benefit industry that adversely impacts BCBSKC’s ability to obtain Financial Credits.

In order to be eligible for and receive the carve-in credits, Employer’s Addendum must be in effect at the time payment of such carve-in credits are to be made.

Employer agrees to fully and accurately disclose and report pharmacy carve-in credits and any other discount, rebate, or other credit received by Employer or retained by BCBSKC and/or its PBM, as required by law.

6.9 Audit of BCBSKC. During the term of this Addendum, Employer may, without charge by BCBSKC, perform an audit once during a Contract Period for the sole purpose of auditing BCBSKC's performance of certain of its obligations under this Addendum. To the extent an audit occurs, BCBSKC agrees only to the following two audit methodologies: (a) testing up to a statistically valid random sample, based upon a 95% confidence level (plus or minus 3% precision) and 97% expected performance; or (b) testing a targeted sample, up to a number of sample items equivalent to that which would result from the above random sample approach. Whether the audit is performed during the term of the Agreement or following termination and regardless of the methodology used, referenced in (a) and (b) above, such samples may only include those claims that were processed by BCBSKC no more than six months prior to the effective date for which the Employer requested the sample. For example, if a sample is requested to be drawn effective as of June 30 of a given year, it could only include claims processed between June 30 and January 1 of the same year. Employer may not request a retroactive effective date for the sample.

Employer may engage a third party to perform any or all of the audit on its behalf upon BCBSKC's prior written consent, not to be unreasonably withheld. Any such third party may not be reimbursed by Employer on a contingency or other method based on identification or value of errors. If Employer engages a third party to perform all or any part of an audit, such third party shall, upon BCBSKC's request (and Employer shall cause such third party to), enter into a data extraction agreement with BCBSKC prior to, and as a condition of, conducting any function of the audit. Employer shall provide BCBSKC with at least thirty (30) business days' notice of its desire to conduct an audit, and the parties (including the third party engaged by Employer, as applicable) shall execute a Records Audit Agreement, which will set forth in detail the terms and conditions of the audit. Notwithstanding anything to the contrary in this Addendum or the Records Audit Agreement, in no event will provider reimbursement or other proprietary information under the control of BCBSKC be subject to audit unless BCBSKC, in its sole discretion, permits access to such information.

6.10 Entire Agreement. This Addendum and the Group Contract(s) constitute the entire Agreement between the parties concerning this subject matter and supersede all other agreements, representations or communications, oral or written, between the parties or their predecessors relating to the transactions contemplated by or which are the subject matter of this Addendum, and both parties understand and agree that prior agreements, practices or statements inconsistent with the language, terms and conditions of this Addendum are of no force or effect.

6.11 Mindful by Blue KC: Mindful initiatives include improved network access to providers trained in crisis support, employer education focused on mental health first aid, and resources to support behavioral health integration into our primary care provider practices. The Mindful by Blue KC initiative provides a set of tools and resources to promote whole person wellness, including a limited number of well-being resource visits and access to Mindful Advocates. The well-being resource visits help with major life events (divorce, adoption, loss), stress, financial issues, childcare, and other everyday challenges through lifestyle coaching. These visits are limited to 3 per issue for each Blue KC member every calendar year. Well-being resource visits are not considered Covered Services and will not be billed (or paid) as claims. Mindful Advocates are licensed clinicians and social workers who match members to providers and guide care plans. They act as a single point of contact for listening, connecting, crisis management, benefits guidance, navigating care, and follow-up.

Article 7 Definitions

Access Fee The amount paid by Employer to BCBSKC for network management and access, determined as set forth in Exhibit B (Rate Exhibit) for each Coverage Class and Product Type combination, multiplied by the number of such Coverage Class and Product Type combinations in effect as of the first day of such month.

Case A Service request for prior authorization submitted by a Provider for one or more specified Covered Services to be performed as part of a single event of care for a Covered Person.

Contract Period The current contract term specified in the Group Contract(s) (which may be referred to in the Group Contract(s) as “Contract Year”).

Coverage Class The level of coverage selected by an Employee as set forth in Exhibit B (Rate Exhibits) (e.g., “Individual”, “Family”, etc.).

Covered Person(s) Those individuals as defined in the Group Contract(s).

Covered Services Those services, supplies, equipment and care as defined in the Group Contract(s).

Cumulative Monthly Claims Limit The amount of Paid Claims for all Covered Persons’ Covered Services for a Contract Period at which Employer has no further obligation, calculated as the sum of the Monthly Claims Limit for each month of the Contract Period to date.

Cumulative Paid Claims The sum of Paid Claims for each month of the Contract Period to date.

Cumulative Prior Payment Amount The sum of the amounts paid by Employer under Article 1.3 for each prior month (i.e., excluding the current month in question) of the Contract Period to date.

Discount The amount of the initial reduction from a provider’s billed charges which a provider has agreed to accept as payment in full at the time of claim payment for covered services provided to Participants. “Discount” does not mean or include any affiliation fees, administration fees, network management fees, provider and pharmaceutical rebates, incentive arrangements, or any other reductions or credits a provider may periodically give BCBSKC or any other amount that a provider may pay BCBSKC for services such as administration, marketing, managed care or quality improvement programs performed by BCBSKC for the provider. BCBSKC retains these amounts and they are not included in the Discount the BCBSKC makes available to Plan Sponsor.

Fiduciary as used in this Addendum means “fiduciary” as defined in ERISA at 29 U.S.C. 1002 (21)(A).

Fixed Cost Fees The amount of money to be paid by the Employer to BCBSKC for services under the Group Contract including such services as claims processing and investigation, utilization management, claims management, production and distribution of member identification cards, wellness services, web-based member services, brokerage fees, BlueCard fees and other general services provided by BCBSKC and third party services providers, unless otherwise identified in Exhibit B. For any month during the Contract Period, Fixed Cost Fees shall equal the amounts set forth in the Fixed Cost Fees section of Exhibit B (Rate Exhibit) for each Coverage Class and Product Type combination, multiplied by the number of such Coverage Class and Product Type combinations in effect as of the first day of such month.

Fixed Premium The Fixed Cost Fees, Pooling Charges, Access Fees and Statutory Assessments as set forth in Exhibit A (Cost-Plus Provisions) and/or Exhibit B (Rate Exhibits), as applicable; provided, that the Access Fees and any Statutory Assessments shall be billed with the Monthly Settlement Report.

Group Contract(s) Those Group Contract(s) identified in Exhibit A (Cost Plus Provisions).

Individual Pooling Limit The amount at which any Paid Claims for a Covered Person's Covered Services in excess of such amount during a Contract Period are not counted as Paid Claims for purposes of determining Employer's claims obligations under Article 1.3 during such Contract Period. The Individual Pooling Limit does not include any capitated payments associated with any Paid Claims or Covered Services. Capitated payments include, but are not limited to, Medical Value and Value-Based and Spira Care Capitation Payments. Medical Value and Value-Based and Spira Care Capitation Payments are value-based payment arrangements with providers participating in certain health care delivery programs, including patient-centered medical homes, accountable care organizations or episode-based medical management. The Individual Pooling Limit does not include Spira Care Capitation Payments. The Individual Pooling Limit does not include Spira Care Capitation Adjustments.

Monthly Claims Limit For any month during the term of this Addendum, the amounts set forth in the Monthly Claims Limit section of Exhibit B (Rate Exhibit) for each Coverage Class and Product Type combination, multiplied by the number of such Coverage Class and Product Type combinations in effect as of the first day of such month.

Monthly Settlement Report The Employer claims, network access and other obligations as reported for a given month by BCBSKC. The Monthly Settlement Report may include Paid Claims, Access Fees and Statutory Assessments, and, during the Runout Period, Runout Services Fee, as applicable.

Paid Claims All payments made as of the date when a valid draft for payment for Covered Services has been issued to the person or persons authorized for such purpose by agreement of the Employer and BCBSKC during the Contract Period and the Runout Period for claims that were incurred while this Addendum was in effect, or for claims that were incurred under this Addendum between the parties for the previous Contract Period, if applicable; including Medical Value Payments and other provider charges, such as capitation (including Spira Care Capitation Payments), when applicable. For purposes of clarification, a claim shall be deemed to be paid when a valid draft for payment has been issued as noted above, even if issued in a later Contract Period from when the claim was incurred. Paid Claims are those amounts paid to a provider, which the provider has agreed to accept as payment in full at the time of claim payment for Covered Services provided to Covered Persons. Paid Claims are not reduced by any administration fees, network management fees, provider and pharmaceutical rebates, incentive arrangements, or any other reductions or credits a provider may periodically give BCBSKC, or any other amounts that a provider may pay BCBSKC for services such as administration, marketing, managed care or quality improvement programs performed by BCBSKC for the provider. BCBSKC retains these amounts and they do not reduce the amount of Paid Claims. All services are deemed to be incurred on the date the service was actually rendered.

Plan as used in this Addendum means plan as defined in ERISA at 29 U.S.C. 1002(3).

Pooling Charges The amount payable by the Employer to BCBSKC for limiting the Employer's claims obligation under the terms of the Cumulative Monthly Claims Limit and Individual Pooling Limit, and, if applicable, for Terminal Liability Coverage. For any month during the Contract Period, Pooling

Charges shall equal the amounts set forth in the Pooling Charges section of Exhibit B (Rate Exhibit) for each Coverage Class and Product Type combination, multiplied by the number of such Coverage Class and Product Type combinations in effect as of the first day of such month.

Product Type The type of product(s) offered by Employer to Covered Persons, as set forth in Exhibit B (Rate Exhibits) (e.g., Blue Advantage, Blue Care, Dental, etc.).

Runout Claims Claims for Covered Services incurred by Covered Persons prior to the termination of this Addendum but paid by BCBSKC during the Runout Period. For purposes of clarification, Runout Claims do not include claims incurred after termination of this Addendum.

Runout Period The first twelve (12) months following termination of this Addendum.

Runout Services The services provided by BCBSKC for Runout Claims after termination of this Addendum.

Runout Services Fee The fee payable by Employer to BCBSKC for Runout Services, which is equal to the sum of: (a) ten percent (10%) of Runout Claims during the month; and (b) ten percent (10%) of the difference between billed charges and the Allowable Charge for all Runout Claims (i.e., 10% of network discounts) during the month.

Statutory Assessments Governmental entities assess a variety of fees, taxes, surcharges and/or assessments on employer-sponsored health coverage. These include, but are not limited to, state premium taxes, Affordable Care Act (ACA) assessments, as well as miscellaneous state or local assessments.

Terminal Liability Coverage Coverage for Runout Claims exceeding a specified maximum at termination of this Addendum.

Terminal Liability Coverage Charges The cost associated with the purchase of Terminal Liability Coverage.

Utilization Management Fees The fees associated with utilization management services.

Other Defined Terms Any other capitalized term used in this Addendum and not specifically defined herein, shall have the meaning ascribed to it in the Group Contract(s).

IN WITNESS WHEREOF, BCBSKC and Employer have caused this Addendum to be executed effective as of the Effective Date.

BY: _____
President, Board of Education

BY: _____

NAME: _____

TITLE: _____

DATE _____

DATE _____

Attested by:

BY: _____
Clerk, Board of Education

Approved as to Form:

BY: _____
Attorney, Board of Education

Exhibit A
Cost Plus Provisions

1. This Addendum shall be applicable to:
 X Employer's Group Health Contract: Group Number(s) 14274000
2. The Individual Pooling Limit per Covered Person shall be \$175,000
3. The Access Fee is due and payable with the Monthly Settlement Report and shall be:
\$14.78 per Employee

4. Minimum Annual Claims Limit:

The greater of: (a) \$31,552,201; or (b) 90% of the amounts set forth in the Monthly Claims Limit section of Exhibit B (Rate Exhibit) for each Coverage Class and Product Type combination, multiplied by the number of such Coverage Class and Product Type combinations for the first month of the Contract Period, times the number of months of the Contract Period as defined in Article 7.

Exhibit B
Rate Exhibits

Fixed Premium

1. The Fixed Cost Fees are as follows:

Employee	\$22.93
Employee/Spouse	\$43.39
Employee/Child(ren)	\$38.82
Family	\$59.38

2. Pooling Charges (including Terminal Liability Coverage Charges, if applicable) are as follows:

Employee	\$170.86
Employee/Spouse	\$323.33
Employee/Child(ren)	\$289.25
Family	\$442.43

3. Access Fees are as follows:

\$14.78 Per Employee Per Month

4. Statutory Assessments are as follows:

A. The Patient-Centered Outcomes Research Institute Fee (aka Comparative Effectiveness Fee) is due and payable with the Monthly Settlement Report and shall be \$3.38 per Covered Person (which equals \$0.28 per Covered Person per month).

B. All other Statutory Assessments are due and payable with the Monthly Settlement Report and shall be \$41.05 per Covered Person (which equals \$3.42 per Covered Person per month).

5. Utilization Management Vendor Fees are as follows:

Muscular Skeletal and Cardiac Utilization Management Vendor Fees are as follows:

Orthopedic Muscular Skeletal Case	\$550 per case
Spinal Muscular Skeletal Case	\$1,250 per case
Surgical Cardiac Case	\$1,750 per case
Cardiac Diagnosis Case	\$130 per case

Exhibit B
Rate Exhibits

Rate Factors

1. Monthly Claims Limit Factors are as follows:

PPO Blue Select Plus Plan

Employee	\$762.68
Employee/Spouse	\$1,393.60
Employee/Child(ren)	\$1,251.92
Family	\$1,889.55

PPO Preferred Care Blue Plan

Employee	\$895.18
Employee/Spouse	\$1,694.31
Employee/Child(ren)	\$1,515.88
Family	\$2,318.44

BlueSelect Plus - EPO Plan

Employee	\$1,030.79
Employee/Spouse	\$1,950.96
Employee/Child(ren)	\$1,745.58
Family	\$2,669.86

Preferred-Care Blue - BlueSaver Plan

Employee	\$849.74
Employee/Spouse	\$1,531.04
Employee/Child(ren)	\$1,374.84
Family	\$2,077.77

BlueSelect Plus - SPIRA EPO Plan

Employee	\$861.79
Employee/Spouse	\$1,555.01
Employee/Child(ren)	\$1,391.24
Family	\$2,127.82

BlueSelect Plus - SPIRA BlueSaver - PPO Plan

Employee	\$754.38
Employee/Spouse	\$1,377.12
Employee/Child(ren)	\$1,237.12
Family	\$1,867.17

2. Terminal Liability Factors are as follows:

PPO Blue Select Plus Plan

Employee	\$1,144.02
Employee/Spouse	\$2,090.40
Employee/Child(ren)	\$1,877.89
Family	\$2,834.32

PPO Preferred Care Blue Plan

Employee	\$1,342.77
Employee/Spouse	\$2,541.46
Employee/Child(ren)	\$2,273.82
Family	\$3,477.66

BlueSelect Plus - EPO Plan

Employee	\$1,546.18
Employee/Spouse	\$2,926.44
Employee/Child(ren)	\$2,618.37
Family	\$4,004.79

Preferred-Care Blue - BlueSaver Plan

Employee	\$1,274.62
Employee/Spouse	\$2,296.56
Employee/Child(ren)	\$2,062.26
Family	\$3,116.66

BlueSelect Plus - SPIRA EPO Plan

Employee	\$1,292.69
Employee/Spouse	\$2,332.52
Employee/Child(ren)	\$2,086.86
Family	\$3,191.73

BlueSelect Plus - SPIRA BlueSaver

Employee	\$1,131.57
Employee/Spouse	\$2,065.67
Employee/Child(ren)	\$1,855.68
Family	\$2,800.75

SPIRA CARE DISCLOSURE

ASO AND COST-PLUS GROUP CONTRACTS

You have chosen to participate in Blue Cross and Blue Shield of Kansas City's (Blue KC) Spira Care program. There are some special financial features of Spira Care that we describe here.

Introduction. Spira Care provides a financial incentive to participating healthcare providers to use their medical judgment in a fashion that provides cost effective, appropriate medical care. Spira Care healthcare providers may receive additional compensation if they operate in a fashion that shows a beneficial cost impact (as measured by standards described later in this disclosure).

Provider Partners. Initially, Spira Care will operate through an arrangement with third-party healthcare provider organizations (collectively, the "**Provider Partners**"). Members will go to the Spira Care clinics to receive care from these Provider Partners through the Spira Care program.

Group's Capitation Payments. Your group will pay a per-member per-month ("**Capitation**") amount for services provided to your members through the Spira Care clinics. This Capitation amount will cover your group's expense for services provided through the Spira Care clinics, except for (a) drugs dispensed at the Spira Care clinics, and (b) any behavioral health services that are beyond what must be provided to members without cost-sharing under the Mental Health Parity and Addiction Equity Act. Your group will be required to pay those drug and behavioral health expenses in the normal way under your contract. They will not be covered by the Capitation amount you pay for services provided through the Spira Care clinics.

The Capitation amount of Spira Care will vary by the age and sex of members and may adjust on January 1 of each year, regardless of your group's plan year. And the Capitation amount for those members covered by a qualified high-deductible health plan will generally be less than the Capitation amount for those members not covered by such a plan.

In addition to receiving the Capitation amount, Blue KC and the Provider Partners will charge those members covered by a qualified high-deductible health plan who have not yet satisfied their deductible for the year an allowable charge for each visit involving non-preventive services. Blue KC and the Provider Partners will collect and keep this allowable charge.

Clinic Operating Performance. There are two special financial aspects of Spira Care. The first involves what is called a "**Clinic Operating Expenses**" calculation. The actual expenses in operating the Spira Care clinics (the Clinic Operating Expenses) for a year may be more or less than the total of the Capitation payments and any member cost-sharing payments made to the Provider Partners for the year. Blue KC and/or the Provider Partners will effectively bear responsibility for the clinic operating performance. Your plan will not be required to pay an additional Capitation amount to make up for any Clinic Operating Expense shortfall.

In determining whether there is an operating loss or gain from the Spira Care clinics, the Clinic Operating Expenses will include not only items like rent, utilities, medical record software, drug

acquisition costs, and information technology support, but also the compensation paid to the healthcare professionals associated with the Spira Care clinics for providing care to members who have selected Spira Care. And in determining the income associated with the clinics (for purposes of determining any clinic operating loss or gain), that income will include not only the total of the Spira Care Capitation and member cost-sharing payments made for the year, but also any amounts paid for drugs dispensed at the clinic.

Sharing of Cost Savings (or Losses). The second special financial feature of Spira Care is that one or more of the Provider Partners will, while making appropriate medical decisions, have a financial incentive to generate savings in the total cost of healthcare provided to members who have selected Spira Care. By total cost of healthcare we mean not just the cost of care provided by the Provider Partner but the cost of all covered healthcare provided to members in the Spira Care program, including care provided outside the Spira Care clinics.

In determining whether there have been cost savings, Blue KC will establish a benchmark and compare the Spira Care program's total cost of healthcare provided to members against that benchmark.

Savings. The intent is that the Provider Partners will perform well, as measured by the standard above, generating savings from what one might otherwise have projected healthcare costs to be. If so, one or more of the Provider Partners will receive incentive compensation equal to a percentage of the savings for the year in question (as those savings are determined under the calculations above).

To pay for all or part of any incentive compensation earned by the Provider Partners, groups in the Spira Care program in subsequent years may pay a larger Capitation amount for Spira Care, or Blue KC may charge higher administrative fees, or both. When successful, the group will experience the benefits of the Spira Care program in real time by seeing its healthcare costs decrease from what one might otherwise have projected them to be.

Losses. If the Provider Partners are not successful in generating savings, and the total cost of care for the Spira Care members instead shows a "loss" (determined under the calculations noted above), one or more of the Provider Partners will be required to bear a portion of that loss. In that event, one or more of the Provider Partners will make a payment to Blue KC equal to a percentage of the loss for the year. This payment will not be credited directly to your group. That means your group will have paid a Spira Care Capitation amount, as well as other healthcare expenses, a portion of which will ultimately come back to Blue KC and not back to your group.

Savings and Losses Not Based on Your Individual Group's Experience. Cost savings or losses will be determined across all groups that participate in Spira Care, including both self-insured and insured groups. This means savings or losses will not be determined based on your group's particular experience. And if any savings or losses are reflected in future years' Capitation amounts, the effect on your group will depend on the number of members in your group during the later year for which the Capitation is adjusted. Further, any Capitation adjustments for future years (to reflect savings or losses) may be different for insured groups that are not Cost-Plus groups than for ASO and Cost-Plus groups.

Blue KC's Interest in Provider Partners. Blue KC, or a subsidiary of Blue KC, has an ownership interest in one or more of the Provider Partners, and has the potential to obtain additional ownership in at least one of the Provider Partners. As a consequence, payments made to those Provider Partners may have a financial impact on Blue KC.

Blue KC or Subsidiary. The financial arrangements with the Provider Partners may actually be made between those providers and a subsidiary of Blue KC, rather than with Blue KC directly.

Agreed to and acknowledged:

By: _____
President, Board of Education
Name: _____
Date: _____

Attested by:

By: _____
Clerk, Board of Education

Approved as to Form:

By: _____
Attorney, Board of Education



PURCHASING UNIVERSAL REQUEST

BLUE VALLEY SCHOOL DISTRICT #229

Department/Bldg.:	Custodial Dept	Requested By:	Matt Brooks
Purpose: (please explain in detail why we need the items or services requested)			
Emergency Repair: Had to repair BVH Gym floor due to water damage by a contractor.			
Fund:	Capital Outlay	Account Number:	23999
Funding Year:	2024/2025	Location(s) items or services are for:	BVH
Does this use Bond Funds? (if yes, see below)			
<input type="checkbox"/> This request includes extended warranty, service or maintenance. Please complete the <u>Bond Warranty Agreement Form on page 2</u>		<input type="checkbox"/> This request includes training or consultation. Please complete <u>Bond Consultant Services Form on Page 3</u>	

Check all that apply to this Purchase:

- | | |
|---|--|
| <input type="checkbox"/> This is a New Contract | <input type="checkbox"/> This is a New Bid/RFP |
| <input type="checkbox"/> This is a Renewal Contract | <input type="checkbox"/> This is a Purchase from Bid/RFP # _____ |
| <input type="checkbox"/> This is a Curriculum purchase | <input type="checkbox"/> This Purchase requires BOE Signatures |
| <input checked="" type="checkbox"/> This can be purchased off of <u>Greenbush</u> | Contract # <u>22.4 ESC-SPORTSFLOORING2024</u> |

Begin Date: 7/8/2024	End Date: 7/29/2024
Company: Lankford Enterprises Inc.	Street Address: 20635 Metcalf
Contact Name: Marie Franklin	City: Bucyrus
Telephone: (913) 681-6224	State: KS
Email: marie@lankford-floors.com	Zip Code: 66013
Cost: \$ 33,210.00 Estimated	
Prior Year Cost: N/A - Not Available	
Terms: (Annual, Multi-Year, One-Time): One-Time	

Month:(board meeting) September 2025 **Budget Administrator** Matt Brooks **Date** 8/8/2025



20635 S Metcalf, Bucyrus, KS 66013

8/6/2025

Blue Valley Public Schools

INVOICE 25534

**Attn Accounts Payable
15020 Metcalf Ave
Overland Park, KS 66283-0901**

=====

TERMS: NET 30 DAYS FROM DATE OF INVOICE
Please remit from this invoice. Statement will not be sent.

B V High gym floor Delta Innovations

We removed and replaced 1,250 sq ft of water damaged flooring and subfloor as needed. Then sanded, Sealed, painted lines and finished the repair area.

AMOUNT DUE-----\$ 33,210.00

THANK YOU FOR YOUR BUSINESS

20635 S. Metcalf, Bucyrus, KS 66013
Phone: 1-800-235-8292
913-681-2244
Fax: 913-681-5407



PURCHASING UNIVERSAL REQUEST

BLUE VALLEY SCHOOL DISTRICT #229

Department/Bldg.:	ITS	Requested By:	John Yates
Purpose: (please explain in detail why we need the items or services requested)			
<p>26-014 schools and buildings Switches Purpose; This purchase will support the replacement cycle of building and school network switches. this was bid through E-Rate.</p>			
Fund:	Bond	Account Number:	44110734-0
Funding Year:	2025/2026	Location(s) items or services are for:	District Wide
Does this use Bond Funds? (if yes, see below)		Yes	
<input type="checkbox"/> This request includes extended warranty, service or maintenance. Please complete the <u>Bond Warranty Agreement Form on page 2</u>		<input type="checkbox"/> This request includes training or consultation. Please complete <u>Bond Consultant Services Form on Page 3</u>	

Check all that apply to this Purchase:

- | | |
|---|--|
| <input type="checkbox"/> This is a New Contract | <input type="checkbox"/> This is a New Bid/RFP |
| <input type="checkbox"/> This is a Renewal Contract | <input type="checkbox"/> This is a Purchase from Bid/RFP # _____ |
| <input type="checkbox"/> This is a Curriculum purchase | <input type="checkbox"/> This Purchase requires BOE Signatures |
| <input checked="" type="checkbox"/> This can be purchased off of ERATE | Contract # FCC Form 470 Number 240015170 |

Begin Date: 8/16/2025	End Date: 8/15/2026
Company: CDW Government	Street Address: 75 Remittance Drive, Suite 1515
Contact Name: Brendan Devlieger	City: Chicago
Telephone: (866) 684-4536	State: IL
Email: brendev@cdwg.com	Zip Code: 60675-1515
Cost: \$ 192,250.00	
Prior Year Cost:	
Terms: (Annual, Multi-Year, One-Time): One-Time	

Month:(board meeting) September 2025 **Budget Administrator** Brian Daley **Date** 8/25/2025



Thank you for choosing CDW. We have received your quote.

QUOTE CONFIRMATION

JOHN YATES,

Thank you for considering CDW•G for your technology needs. The details of your quote are below. **If you are an eProcurement or single sign on customer, please log into your system to access the CDW site.** You can search for your quote to retrieve and transfer back into your system for processing.

For all other customers, click below to convert your quote to an order.

Convert Quote to Order

QUOTE #	QUOTE DATE	QUOTE REFERENCE	CUSTOMER #	GRAND TOTAL
PGMP302	1/14/2025	ERATE 4650S	1685938	\$192,250.00

QUOTE DETAILS				
ITEM	QTY	CDW#	UNIT PRICE	EXT. PRICE
Juniper EX4650 48x25GbE+8x100GbE Ethernet Switch	25	5237827	\$7,690.00	\$192,250.00
Mfg. Part#: EX4650-48Y-AFO				
UNSPSC: 43222612				
Contract: MARKET				

SUBTOTAL	\$192,250.00
SHIPPING	\$0.00
SALES TAX	\$0.00
GRAND TOTAL	\$192,250.00

PURCHASER BILLING INFO	DELIVER TO
Billing Address: BLUE VALLEY SCHOOL DISTRICT ACCTS PAYABLE PO BOX 23901 OVERLAND PARK, KS 66283-0901 Phone: (913) 681-4000 Payment Terms: ERATE QUOTES ONLY	Shipping Address: BLUE VALLEY SCHOOL DISTRICT JOHN YATES 7490 W 149TH TER OVERLAND PARK, KS 66223-2240 Shipping Method: DROP SHIP-GROUND
	Please remit payments to: CDW Government 75 Remittance Drive Suite 1515 Chicago, IL 60675-1515



Sales Contact Info

Brendan Devlieger | (866) 684-4534 | brendev@cdwg.com

Need Help?



My Account



Support



Call 800.800.4239

[About Us](#) | [Privacy Policy](#) | [Terms and Conditions](#)

This order is subject to CDW's Terms and Conditions of Sales and Service Projects at

<http://www.cdwg.com/content/terms-conditions/product-sales.aspx>

For more information, contact a CDW account manager.

© 2025 CDW•G LLC, 200 N. Milwaukee Avenue, Vernon Hills, IL 60061 | 800.808.4239

Funding Commitment Decision Letter

Funding Year 2025

Contact Information:

Toby Sykes
BLUE VALLEY UNIF SCH DIST 229
15020 METCALF AVE
OVERLAND PARK, KS 66283
tobysykes@eratesolutions.com

FCC Form 471: 251026545**BEN:** 137622**Wave:** 1**Application Nickname:** BLUE VALLEY UNIF SCH
DIST 229 FY2025.C2

Totals

Total Committed	\$588,300.00
------------------------	---------------------

What is in this letter?

Thank you for submitting your application for Funding Year 2025 Schools and Libraries Program (E-rate) funding. Attached to this letter, you will find the funding statuses for the FCC Form(s) 471, Services Ordered and Certification Form, that you submitted and referenced above.

The Universal Service Administrative Company (USAC) is sending this information to both the associated applicant(s) and the service provider(s) so that you can work together to complete the funding process.

Next Steps

1. Work with your service provider(s) to determine if your bills will be discounted or if you will request reimbursement from USAC after paying the full cost for the services you receive.
2. Review the [Children's Internet Protection Act \(CIPA\)](#) requirements and file the [FCC Form 486](#) (Service Confirmation and CIPA Certification Form). **The deadline to submit this form is 120 days from the date of this letter or from the service start date (whichever is later).**
3. Invoice USAC

- **If you (the applicant) are invoicing USAC:** You must pay your service provider(s) the full cost for the services you receive and file the [FCC Form 472](#), the Billed Entity Applicant Reimbursement (BEAR) Form, to invoice USAC for reimbursement of the discounted amount.
- **If your service provider(s) is invoicing USAC:** The service provider(s) must provide services, bill the applicant for the non-discounted share, and file the [FCC Form 474](#), the Service Provider Invoice (SPI) form, to invoice USAC for reimbursement for the discounted portion of costs. Every funding year, service providers must file an [FCC Form 473](#), the Service Provider Annual Certification Form, to be able to submit invoices and to receive disbursements.
- **To receive an invoice deadline extension, the applicant or service provider must request an extension on or before the last date to invoice. If you anticipate, for any reason, that invoices cannot be filed on time, USAC will grant a one-time, 120-day invoice deadline extension if timely requested.**

How to Appeal or Request a Waiver of a Decision

You can appeal or request a waiver of a decision in this letter **within 60 calendar days** of the date of this letter. Failure to meet this deadline will result in an automatic dismissal of your appeal or waiver request.

Note: The Federal Communications Commission (FCC) will not accept appeals of USAC decisions that have not first been appealed to USAC. However, if you are seeking a waiver of E-rate program rules, you must submit your request to the FCC and not to USAC. USAC is not able to waive the E-rate program rules.

- **To submit your appeal to USAC,** visit the Appeals section in the [E-rate Productivity Center \(EPC\)](#) and provide the required information. USAC will reply to your appeal submissions to confirm receipt. Visit USAC's [website](#) for additional information on submitting an appeal to USAC, including step-by-step instructions.
- **To request a waiver of the FCC's rules,** please submit it to the FCC in proceeding number CC Docket No. 02-6 using the [Electronic Comment Filing System \(ECFS\)](#). Include your contact information, a statement that your filing is a waiver request, identifying information, the FCC rule(s) for which you are seeking a waiver, a full description of the relevant facts that you believe support your waiver request and any related relief, and any supporting documentation.

For appeals to USAC or to the FCC, be sure to keep a copy of your entire appeal, including any correspondence and documentation, and provide a copy to the affected service provider(s).

Obligation to Pay Non-Discount Portion

Applicants are required to pay the non-discount portion of the cost of the eligible products and/or services to their service providers. Service providers are required to bill applicants for the non-discount portion of costs for the eligible products and/or services. The FCC stated that requiring applicants to pay the non-discounted share of costs ensures efficiency and accountability in the program. If using the BEAR invoicing method, the applicant must pay the service provider in full (the non-discount plus discount portion) **before** seeking reimbursement from USAC. If using the SPI invoicing method, the service provider must first bill the applicant **before** invoicing USAC.

Notice on Rules and Funds Availability

The applicants' receipt of funding commitments is contingent on their compliance with all statutory, regulatory, and procedural requirements of the Schools and Libraries Program and the FCC's rules. Applicants who have received funding commitments continue to be subject to audits and other reviews that USAC and/or the FCC may undertake to assure that committed funds are being used in accordance with such requirements. USAC may be required to reduce or cancel funding commitments that were not issued in accordance with such requirements, whether due to action or inaction of USAC, the applicant, or the service provider. USAC, and other appropriate authorities (including but not limited to the FCC), may pursue enforcement actions and other means of recourse to collect improperly disbursed funds.

Funding Commitment Decision Overview

Funding Year 2025

Application Comments for FCC Form 471: #251026545

The applicant did not submit any RAL corrections.

Funding Commitment Decision Overview

Funding Request Number (FRN)	Service Provider Name	Amount Requested	Amount Committed	Status
2599035612	CDW Government LLC	\$588,300.00	\$588,300.00	Funded

FRN 2599035612	Service Type Internal Connections	Status Funded
--------------------------	---	-------------------------

Dollars Committed			
Monthly Cost		One-time Cost	
Months of Service	12		
Total Eligible Recurring Charges	\$0.00	Total Eligible One Time Charges	\$1,470,750.00
Total Pre-discount Charges		\$1,470,750.00	
Discount Rate		40.00%	
Committed Amount		\$588,300.00	

Dates	
Service Start Date	7/1/2025
Contract Expiration Date	9/30/2026
Contract Award Date	3/12/2025
Service Delivery Deadline	9/30/2026
Expiration Date (All Extensions)	

Service Provider and Contract Information	
Service Provider	CDW Government LLC
SPIN (498ID)	143005588
Contract Number	137484
Account Number	
Establishing FCC Form 470	250011237

Consultant Information	
Consultant Name	Toby Sykes
Consultant's Employer	eRate Solutions, L.L.C.
CRN	16024804

Funding Commitment Decision Comments

MR1: Approved as submitted.

E-RATE PURCHASE AGREEMENT

Form – E-Rate FY27 2024-2025

Contract Number: 117577

This E-Rate Customer Purchase Agreement (this “Agreement”) is entered into on April 1, 2024 (“Effective Date”) and is made by and between CDW Government LLC an Illinois limited liability corporation with an office at 230 N. Milwaukee Ave., Vernon Hills, Illinois 60061 (“Seller”), and Blue Valley Unified School District 229, a non-profit school or library eligible for Universal Service funding, as defined below.

E-Rate Contract Number	117577	Spin #	143005588
E-Rate Funding Year	2024	FCC Registration #	0012123287
Customer	Blue Valley Unified School District 229 15020 Metcalf Ave Overland Park, KS, 66283	Seller	CDW Government LLC 230 N. Milwaukee Avenue Vernon Hills, IL 60061
Effective Date	April 1, 2024	Quoted Items (see exhibit 1)	470# 240015170

1. DEFINITIONS

As used in the Agreement, the following terms shall have the meanings set forth below:

- A. “Universal Service Administrative Co.” or “USAC” – The not for profit organization designated by the U.S. Federal Communications Commission (“FCC”) to administer and ensure compliance with the Universal Services Fund.
- B. “SLP” - The Schools and Libraries Program of the Universal Service Fund, which includes the E-Rate Program and that is administered by USAC under the direction of the FCC.
- C. “E-Rate” – The education rate funding program that is a part of SLP that provides discounts to keep students and library patrons connected to broadband and voice services and which is one of the programs that form the Universal Service Program.
- D. “Funding Commitment Decision Letter” or “FCDL” – A letter that a Customer receives from USAC which indicates the applicable discount amount for a specific funding year.
- E. “Products” – E-Rate eligible products or services that include computer related hardware but are not limited to caching servers, routers, switches, wireless access points, installation, and warranty maintenance and other items which are eligible for E-Rate discounts in accordance with the rules issued by USAC.
- F. “Funding Year” – The specific calendar period, as defined by the SLP, during which the Customer is approved for funding or discounts on Products. FY 2023 is in reference to the program year.

2. TERMS AND CONDITIONS

All orders submitted to Seller by Customer for Products under this Agreement are subject to the terms and conditions on Seller’s website at <https://www.cdwg.com/content/cdwg/en/terms-conditions/sales-and-service-projects.html> (the “Sales and Service Projects”), unless otherwise stated herein.

3. PURCHASE AUTHORIZATIONS

A. E-Rate Status

- i. Customer represents and warrants that it qualifies as eligible under the SLP to receive E-Rate funding.
- ii. CUSTOMER FURTHER ACKNOWLEDGES AND AGREES THAT THIS AGREEMENT, WHEN EXECUTED, CONSTITUTES A CONTRACT AS REQUIRED BY USAC and the SLP.

B. E-Rate Purchases

CDW Government LLC

SPIN #143005588

2/16/2024

To the extent allowable, all information and documents hereby submitted in response to the Request for Quote (“RFQ”) furnished by Blue Valley Unified School District 229 are the Proprietary and Confidential property of CDW Government LLC (“CDW•G”).

© CDW Government LLC 2023

E-RATE PURCHASE AGREEMENT

Form – E-Rate FY27 2024-2025

Contract Number: 117577

- i. Payment terms are subject to continuing credit approval by Seller. Seller may change credit or payment terms at any time when, in Seller's opinion, Customer's financial condition, previous payment record, or the nature of Customer's relationship with Seller so warrants.
- ii. Seller may discontinue performance under this Agreement (i) if Customer fails to pay any sum when due under this Agreement or any other agreement with Seller until payment is received or (ii) if Customer is in violation of applicable laws and regulations.

A. Price

The Price shall be as set forth on the Customer's quote from Seller and which is in the form attached hereto as Exhibit I, and as amended from time to time. All prices are exclusive of federal, state, local, or other taxes, which shall be the responsibility of the Customer.

Payment Terms

- i. All payments, regardless of method, shall be submitted to "Accounts Receivable", please contact your account manager for payment method options.
- ii. CUSTOMER MAY EITHER WAIT TO PLACE AN ORDER PRIOR TO OR AFTER RECEIPT OF ITS FCDL. IN THE EVENT THAT CUSTOMER PLACES AN ORDER PRIOR TO RECEIPT OF THE FCDL, CUSTOMER SHALL BE RESPONSIBLE FOR PAYMENT OF THE ENTIRE PURCHASE PRICE WITHOUT REGARD TO SLP FUNDING.
- iii. Customer must choose one of the following payment methods. However, Customers that choose to order Products prior to receiving their FCDL must follow the BEAR payment method.
 - Form 474 Service Provider Invoice (SPI) Method**
Seller will invoice the Customer for the Product price, as set forth on the Product quote, net of the FCDL amount. Customer shall be responsible for making payment within thirty (30) days from date of invoice.
 - Form 472 Billed Entity Applicant Reimbursement (BEAR) Method**
Seller will invoice Customer, upon Product shipment, for the total purchase price without regard to any SLP funding applied to that purchase price for the Products. Customer shall pay the invoiced amount within thirty (30) days from the date of invoice.
- iv. Seller accepts BEAR orders beginning April 1 before the beginning of the Funding Year. Seller accepts SPI orders beginning July 1 of the Funding Year when Customer has received its FCDL and completed the FCC Form 486, Seller DOES NOT accept SPI orders before July 1 of the Funding Year, or prior to the Form 486 approval by USAC.

6. NON-ASSIGNABILITY AGREEMENT

Customer shall not assign or otherwise transfer its rights or delegate its obligations under this Agreement without Seller's advance written consent. Any attempted assignment, transfer or delegation without such consent shall be void.

The term of this Agreement shall commence on April 1, 2024 ("Effective Date") and be valid through the later of the Funding Year 2024 or 9/30/2025.

- i. Seller may terminate this Agreement at any time for any reason upon thirty (30) days prior written notice to the Customer.

Customer may terminate this Agreement or withdraw an order upon written notice to Seller if: (a) funds are not appropriated to Customer under this program, or (b) Customer's School Board rejects this Agreement ("Termination Notice"). In the event that Customer terminates this Agreement due to non-appropriation of funds, or termination for convenience, then Seller may immediately cease performance. However, the Customer shall remain liable for any Products that have shipped or services, already provided, or have been subscribed or purchased prior to Seller's receipt of the Termination Notice. Customer shall also be responsible for any of Seller's out-of-pocket costs arising as a result of any such termination.

CDW Government LLC

SPIN #143005588

2/16/2024

To the extent allowable, all information and documents hereby submitted in response to the Request for Quote ("RFQ") furnished by Blue Valley Unified School District 229 are the Proprietary and Confidential property of CDW Government LLC ("CDW•G").
© CDW Government LLC 2023

E-RATE PURCHASE AGREEMENT

Form – E-Rate FY27 2024-2025

Contract Number: 117577

IN WITNESS WHEREOF, the parties hereto have executed this Agreement the day and year first above written.

CDW Government LLC

Blue Valley Unified School District 229

(Authorized Signature)

(Authorized Signature)

Printed Name

Printed Name

Title: _____

Title: CIO

Date: _____

Date: 3-20-24



Thank you for choosing CDW. We have received your quote.

Hardware Software Services IT Solutions Brands Research Hub

QUOTE CONFIRMATION

JOHN YATES,

Thank you for considering CDW•G for your technology needs. The details of your quote are below. **If you are an eProcurement or single sign on customer, please log into your system to access the CDW site.** You can search for your quote to retrieve and transfer back into your system for processing.

For all other customers, click below to convert your quote to an order.

Convert Quote to Order

QUOTE #	QUOTE DATE	QUOTE REFERENCE	CUSTOMER #	GRAND TOTAL
NSWJ415	2/12/2024	BVSD ERATE	1685938	\$1,606,500.00

QUOTE DETAILS

ITEM	QTY	CDW#	UNIT PRICE	EXT. PRICE
Juniper Networks EX Series EX2300-C-12P - switch - 12 ports - managed - rac Mfg. Part#: EX2300-C-12P UNSPSC: 43222612 Contract: MARKET	100	4174696	\$547.00	\$54,700.00
Juniper EX3400 48 Ports Compact Access Ethernet Switch Mfg. Part#: EX3400-48P UNSPSC: 43222612 Contract: MARKET	100	4111095	\$1,987.00	\$198,700.00
Juniper Switch - 12X10G - 36X2.5G - 2X100G Mfg. Part#: EX4400-48MP Contract: MARKET	100	6875745	\$4,660.00	\$466,000.00
Juniper Networks - power supply - hot-plug redundant - 1600 Watt Mfg. Part#: JPSU-1600-C-AC-AFO Contract: MARKET	100	6875749	\$513.00	\$51,300.00
Juniper EX4650 48x25GbE+8x100GbE Ethernet Switch Mfg. Part#: EX4650-48Y-AFO UNSPSC: 43222612 Contract: MARKET	50	5237827	\$8,460.00	\$423,000.00
Juniper Networks QFX Series QFX5120-48Y - switch - 48 ports - managed - rac Mfg. Part#: QFX5120-48Y-AFO2 Contract: MARKET	50	5798140	\$8,256.00	\$412,800.00

SUBTOTAL \$1,606,500.00

E-Rate Order Process

1. Ordering

Purchase orders shall be submitted through electronic means (email, electronic data interchange (EDI), etc.) directly to Customer's dedicated account manager. Alternatively, if a copy must be sent via mail, common courier, etc., please reach out to your account manager for the appropriate mailing address.

2. Required Information

All orders must include

- a. Contact name, Phone number
- b. Purchase order number
- c. Part number, Product description
- d. Pre-discount and discounted product price
- e. Percentage Customer owes and percentage SLD owes (SPI – Form 474 Method)
- f. Ship to location, Bill to location
- g. FCC Form 471 Number (also known as Application Number)
- h. FRN (Funding Request Number) for each part number
- i. Billing method (BEAR – Form 472 or SPI – Form 474)

SEPARATE PURCHASE ORDERS SHOULD BE SUBMITTED FOR PRODUCTS THAT ARE NOT ELIGIBLE FOR E-RATE FUNDING. ALL ORDERS ARE SUBJECT TO ACCEPTANCE BY SELLER.

PO TOTAL SHOULD REFLECT FULL PURCHASE PRICE OF ORDER

3. Assistance With Order

Customer may call 1-800-328-4239 for assistance on any purchase order. Any terms or conditions stated in or on the Customer's purchase order which are not consistent with or in addition to the terms and conditions in this Agreement or the Product Sales Terms and Conditions shall be null and void and shall not be applicable hereto or binding on Seller. IN THE CASE OF CHANGES TO PRODUCTS AFTER A CUSTOMER ORDER HAS BEEN ACCEPTED BUT BEFORE THE PRODUCT HAS SHIPPED, SELLER WILL MAKE REASONABLE EFFORTS TO MAKE AVAILABLE TO THE CUSTOMER A COMPARABLE OR BETTER PRODUCT AT THE SAME OR LESSER PRICE WHEN OR IF AVAILABLE, UPON APPROVAL FROM SLD ON PRODUCT SUBSTITUTION.

4. Price and Payment Terms

a. Price

Price shall be as stated in the quotation attached hereto as Exhibit I by Seller's Account Manager. Prices are exclusive of federal, state, local, or other taxes, which shall be the responsibility of the Customer. Any taxes will be listed separately on the invoice.

b. Payment Terms (Customer must choose one)

i. Form 474 Service Provider Invoice (SPI) Method

➤ Seller will invoice Customer for their portion of the Products upon shipment of Product and Customer shall pay the invoiced amount (discounted amount owed by Customer) within thirty (30) days from date of invoice.

ii. Form 472 Billed Entity Applicant Reimbursement (BEAR) Method

➤ Seller will invoice Customer for pre-discount portion of the Products upon shipment of Product and Customer shall pay the invoiced amount (full amount owed by Customer) within thirty (30) days from the date of invoice.

5. Payment Method

In adherence to Federal E-rate compliance regulations, CDW-G's quoted price is all-inclusive of any and all discounts, if applicable. No further discounts will be applied during time of invoice.

All payments for both methods shall be submitted to the address presented below WHERE APPLICABLE:

ACH PAYMENT INFORMATION:	CHECK PAYMENT INFORMATION:
E-mail Remittance To: gachremittance@cdw.com	CDW Government
THE NORTHERN TRUST	75 Remittance Drive Suite 1515
50 SOUTH LASALLE STREET	Chicago, IL 60675-1515
CHICAGO, IL 60675	
ROUTING NO.: 071000152	
ACCOUNT NAME: CDW GOVERNMENT	
ACCOUNT NO.: 91057	

i. Payment terms are subject to continuing credit approval by Seller. Seller may change credit or payment terms at any time when, in Seller's opinion, Customer's financial condition, previous payment record, or the nature of Customer's relationship with Seller so warrants.

ii. Seller may discontinue performance under this Agreement (i) if Customer fails to pay any sum when due under this Agreement or any other agreement with Seller until payment is received or (ii) if Customer is in violation of applicable regulations.

NOTWITHSTANDING ANYTHING TO THE CONTRARY, CUSTOMER IS RESPONSIBLE FOR PAYMENT OF 100% THE PRICE OF PRODUCTS IN THE CASE WHERE CUSTOMER PLACES ORDER FOR PRODUCTS SLD DISALLOWS CUSTOMER'S REQUEST FOR DISCOUNT AND



PURCHASING UNIVERSAL REQUEST

BLUE VALLEY SCHOOL DISTRICT #229

Department/Bldg.:	Grounds	Requested By:	Caleb Clements
Purpose: (please explain in detail why we need the items or services requested)			
Grass Seed for the district.			
Fund:	Capital Outlay	Account Number:	23987
Funding Year:	2025/2026	Location(s) items or services are for:	BG
Does this use Bond Funds? (if yes, see below)			
<input type="checkbox"/> This request includes extended warranty, service or maintenance. Please complete the <u>Bond Warranty Agreement Form on page 2</u>		<input type="checkbox"/> This request includes training or consultation. Please complete <u>Bond Consultant Services Form on Page 3</u>	

Check all that apply to this Purchase:

- | | |
|--|--|
| <input type="checkbox"/> This is a New Contract | <input checked="" type="checkbox"/> This is a New Bid/RFP |
| <input type="checkbox"/> This is a Renewal Contract | <input checked="" type="checkbox"/> This is a Purchase from Bid/RFP # <u>26008</u> |
| <input type="checkbox"/> This is a Curriculum purchase | <input type="checkbox"/> This Purchase requires BOE Signatures |
| <input type="checkbox"/> This can be purchased off of _____ Contract # _____ | |

Begin Date: 9/8/2025	End Date: 10/31/2025
Company: Grass Pad Inc.	Street Address: 425 N. Rawhide
Contact Name: Todd Winkelman	City: Olathe
Telephone: (913) 660-3429	State: KS
Email: todd@grasspad.com	Zip Code: 66061
Cost:	\$ 90,972.80
Prior Year Cost:	N/A
Terms: (Annual, Multi-Year, One-Time): One-Time	

Month:(board meeting) September 2025 **Budget Administrator** Caleb Clements **Date** 8/25/2025

26008 - Grass Seed																
Line Item	Quantity	Description	Reinders, Inc			Rare Agricultural Products, LLP				GRASS PAD INC.			Harrell's, LLC			
			Unit Cost	Unit Measure (50lb Bags)	Extended Price	Unit Cost	Unit Measure (50lb Bags)	Extended Price	Additional Information	Unit Cost	Unit Measure (50lb Bags)	Extended Price	Unit Cost	Unit Measure (50lb Bags)	Extended Price	Additional Information
1	160	Grass Seed Mix 80/20 Purity Variety/Kind 39.70% NIGHTCRAWLERTALL FESCUE 90% Germination WA 39.65% FAYETTE TALL FESCUE 90% Germination WA 19.81% FIELDER KENTUCKY BLUEGRASS 85% Germination WA 00.00% Other Crop Seeds 00.77% Inert Matter 00.00% Weed Seeds Noxious Weed Seeds: None Certified Blue Tag Seed No Coating (8000lbs Total)	\$ 72.50	50lb/Bag	\$11,600.00	\$ 104.98	50 lb bags	\$16,796.80	We also have 2000 lb totes	\$ 62.80	#50	\$10,048.00	\$ 76.00	50lb bag	\$12,160.00	Harrells Matrix Plus 90/10 Fescue/ Blue
2	1100	Grass Seed Mix 50/30/20 Purity Variety/Kind 29.63% TETRASPORT PERENNIAL RYEGRASS 90% Germination OR 24.88% NIGHTCRAWLER TALL FESCUE 90% Germination WA 24.76% FAYETTE TALL FESCUE 90% Germination WA 19.83% FIELDER KENTUCKY BLUEGRASS 85% Germination WA 00.00% Other Crop Seeds 00.90% Inert Matter 00.00% Weed Seeds Noxious Weed Seeds: None Certified Blue Tag Seed No Coating (22000 lbs. Total)	\$ 74.50	50lb/Bag	\$81,950.00	\$ 105.84	50 lb bags	\$116,424.00		\$ 63.97	#50	\$70,367.00		no bid		no bid
3	20	TALL FESCUE-PERENNIAL RYE GRASS-MICROCLOVER SEED MIXTURE Purity Variety/Kind 29.96% HOUNDOG & TALL FESCUE 90% Germination 90% Germination+Hard Seed OR 27.43% ROWDIER TALL FESCUE 90% Germination 90% Germination+Hard Seed WA 27.35% GARRISON TALL FESCUE 90% Germination 90% Germination+Hard Seed OR 09.9L% FIESTA CI NCO PERENNIALRYEGRASS 90% Germination 90% Germination+Hard Seed OR 02.41% PIPOLINA MICROCLOVER BRAND WHITECLOVER 76% Germination 14% Hard Seed 90% Germination+Hard Seed NZ/OR 00.08% Other Crop Seeds 2.86% Inert Matter (includes 2.58% Nitro-Coat coating) 00.00% Weed Seeds Noxious Weed Seeds: None Certified Blue Tag Seed Clover needs coating (rest of seed does not) (1000 lbs. Total)	\$ 101.50	50lb/Bag	\$2,030.00	\$ 134.65	50 lb bags	\$2,693.00		\$ 89.93	#50	\$1,798.60		no bid		no bid
4	80	GRASS SEED MIXTURE Purity Variety/Kind 33.58% MERCURY KENTUCKY BLUEGRASS 85% Germination ID 33.12% JACKRABBIT KENTUCKY BLUEGRASS 85% Germination WA 32.45% NORTHERN EXPOSURE KENTUCKY BLUEGRASS 85% Germination WA 00.03% Other Crop Seeds 00.79% Inert Matter 00.03% Weed Seeds Noxious Weed Seeds: None Certified Blue Tag Seed No Coating (4000 lbs. Total)	\$ 122.50	50lb/Bag	\$9,800.00	\$ 134.98	50 lb bags	\$10,798.40		\$ 109.49	#50	\$8,759.20	\$ 318.3300	50lb bag	\$25,466.40	Bid Mountain View 3655S bluegrass blend
Totals:					\$105,380.00			\$146,712.20			\$90,972.80		Incomplete		\$37,626.40	



PURCHASING UNIVERSAL REQUEST

BLUE VALLEY SCHOOL DISTRICT #229

Department/Bldg.:	Grounds	Requested By:	Caleb Clements
Purpose: (please explain in detail why we need the items or services requested)			
Purchase of new grounds trailer.			
Fund:	Capital Outlay	Account Number:	26695
Funding Year:	2025/2026	Location(s) items or services are for:	SSC
Does this use Bond Funds? (if yes, see below)		No	
<input type="checkbox"/> This request includes extended warranty, service or maintenance. Please complete the <u>Bond Warranty Agreement Form on page 2</u>		<input type="checkbox"/> This request includes training or consultation. Please complete <u>Bond Consultant Services Form on Page 3</u>	

Check all that apply to this Purchase:

- | | |
|--|--|
| <input type="checkbox"/> This is a New Contract | <input checked="" type="checkbox"/> This is a New Bid/RFP |
| <input type="checkbox"/> This is a Renewal Contract | <input checked="" type="checkbox"/> This is a Purchase from Bid/RFP # <u>26009</u> |
| <input type="checkbox"/> This is a Curriculum purchase | <input type="checkbox"/> This Purchase requires BOE Signatures |
| <input type="checkbox"/> This can be purchased off of _____ Contract # _____ | |

Begin Date: 9/8/2025	End Date: 3/31/2026
Company: Hoyt's Trailer Center	Street Address: 2613 NW Stina Court
Contact Name: Nathan Moore	City: Topeka
Telephone: (785) 235-1086	State: KS
Email: mnathan@hoytstc.com	Zip Code: 66618
Cost:	\$ 28,850.00
Prior Year Cost:	N/A
Terms: (Annual, Multi-Year, One-Time): One-Time	

Month:(board meeting) September 2025 **Budget Administrator** Jake Slabodnik **Date** 8/25/2025

26009 - Grounds Trailer																								
Line Item	Description	Quantity	Hoyt's Trailer Center				Legacy Brothers Inc				Midwest Peterbilt Group					Coleman Equipment, Inc.					Roadbuilders Machinery & Supply Co., Inc.			
			Manufacturer	Model	Unit Cost	Extended Cost	Manufacturer	Model	Unit Cost	Extended Cost	Manufacturer	Model	Unit Cost	Extended Cost	Additional Information	Manufacturer	Model	Unit Cost	Extended Cost	Additional Information	Manufacturer	Model	Unit Cost	Extended Cost
1	New Diamond C Trailer Model DET or Equal GVWR - 208 Package (18K GVWR) Length/Width - 24' x 102" - 208 pkg Axles - 2 - 8000 lb. Oil-Bath standard Brakes - Electric Over Hydraulic Disc Suspension - Torsion Axles Pull Type - Bumper Pull standard Frame - Engineered Beam Frame standard Tilt - Electric/Hydraulic Powered Tilt standard Deck - 4' Stationary Deck at Front Paint Type - DM Difference Maker Coating System standard Paint Color - Onyx Black standard Floor - Blackwood Lumber Full Cross-Members - 3" I-Beam on 14" Centers standard Jack - 20000 lb Hydraulic Jack Coupler - 2-5/16" - 21000 lb. Demco EZ-Latch Flat-Mount standard Storage - HD V-Tongue Lid standard Storage - Underslung Component Box standard Storage - 10' x 12' x 53" Underslung Box Winch - 12K Pop-Up Winch Box with Bed Roller Winch - Winch Upgrade - Crown 27HDC Battery Upgrade Battery/Charger - Crown 27HDC Battery Upgrade Battery/Charger - Solar Charging System 7 watts Lace Rail - 5" Channel - 3/8" Rub Rail w/ Stake Pockets & Pipe Spools standard, Slide Track & Ratchets - No Slide Track standard Tie Downs - 5/8" D-Rings (8) Steps - Front Retractable Steps standard Steps - Mid Turn Light/Step Combo standard Lights - All LED Lights standard Lights - Extra 3/4" Clearance Lights (2) Tie Size - 215/75R17.5 18 Ply Radial standard Wheel Color - Black standard Spare Mount - Under-Frame Spare Mount standard	1	Diamond C	DET 208	\$ 28,850.00	\$28,850.00	Diamond C	DET	\$ 30,686.00	\$30,686.00	Behnke	GDFB8X24TPT-XL-20E	\$ 35,657.00	\$35,657.00	Lead time is approximately 14 weeks from the date of order.	Redi Haul	RH20-204FS	\$ 38,000.00	\$38,000.00	only difference is we have stronger axels. (20K GVWR)	Holden Industries Inc.	HTB18	\$ 41,755.00	\$41,755.00
Totals:					\$28,850.00			\$30,686.00					\$35,657.00					\$38,000.00					\$41,755.00	
Describe the standard warranty period and what is covered. Describe how we submit a warranty claim and include who would perform warranty repairs.			2 year component warranty and 6 year structure defect warranty				Please see full warranty information attached to packet.				Behnke Trailers come with a prorated 5 year warranty: Year 1: 100% Year 2: 80% Year 3: 60% Year 4: 40% Year 5: 20% Trailer finish is warrantied for a period of 120 days. This warranty does not cover winches, lights, couplers, brakes, tongue jacks, springs and tires or wheels. This warranty also excludes all other component parts. Specifically, and without limitation, Company provides no warranty, express or implied, of any type related to the tires, brakes or wheel bearings of any trailer. Manufacturer of said components should be contacted regarding warranty on said items. Warranty issues could be handled by either reaching out to myself and I can arrange the claim through Behnke, or by the school district reaching out to Behnke directly. Warranty repairs can be made through Behnke directly or through a Behnke approved service provider.					LIFETIME LIMITED WARRANTY REDI HAUL TRAILERS warrants your trailer will be free from defects in materials and workmanship, to the original purchaser. The trailer warranted hereunder must be operated by the purchaser in accordance with the practice approved by REDI HAUL TRAILERS, with loads not exceeding the manufacturer's rated capacities and subject to all terms and conditions of this limited warranty. For warranty claim consideration please get with the service department at Coleman Equipment to start the process and perform any warranty repairs.					Warranty period is 1 year all parts and labor, unlimited mileage. Claim can be submitted directly to the manufacturer, Holden Industries, or Roadbuilders Machinery & Supply Co., Inc. Either company can provide repairs.			
Does your bid meet minimum requirements? Please describe any deviations.			yes				Yes				Nonconformities: Make/Model: Behnke GDFB8X24TPT-XL-20E GVWR: 20k Frame: Behnke does NOT use an engineered beam Coating: Metal components will be powder coated Flooring: Full composite rubber decking is quoted Crossmembers: 3" channels on 16" centers Underslung component box: 12"x12"x36" tool box located on RH side of trailer Battery: Includes standard Behnke battery					Yes					Meets complete spec with no deviations.			
Must be able to deliver to Blue Valley USD 229 Grounds Department, 7484 W. 149th Terrace, Overland Park 66223. Can you meet this requirement?			yes				Yes				Quoted price includes delivery to Blue Valley UDS 229 Grounds Department.					Yes					Yes			



PURCHASING UNIVERSAL REQUEST

BLUE VALLEY SCHOOL DISTRICT #229

Department/Bldg.:	Grounds	Requested By:	Caleb Clements
Purpose: (please explain in detail why we need the items or services requested)			
Fertilizer for the district. Reinders - \$12,312.00 Grass Pad - \$8,075.20			
Fund:	Capital Outlay	Account Number:	32901
Funding Year:	2025/2026	Location(s) items or services are for:	BG
Does this use Bond Funds? (if yes, see below)			
<input type="checkbox"/> This request includes extended warranty, service or maintenance. Please complete the <u>Bond Warranty Agreement Form on page 2</u>		<input type="checkbox"/> This request includes training or consultation. Please complete <u>Bond Consultant Services Form on Page 3</u>	

Check all that apply to this Purchase:

- | | |
|--|--|
| <input type="checkbox"/> This is a New Contract | <input checked="" type="checkbox"/> This is a New Bid/RFP |
| <input type="checkbox"/> This is a Renewal Contract | <input checked="" type="checkbox"/> This is a Purchase from Bid/RFP # <u>26010</u> |
| <input type="checkbox"/> This is a Curriculum purchase | <input type="checkbox"/> This Purchase requires BOE Signatures |
| <input type="checkbox"/> This can be purchased off of _____ Contract # _____ | |

Begin Date: 9/8/2025	End Date: 10/31/2025
Company: Various	Street Address:
Contact Name:	City:
Telephone:	State:
Email:	Zip Code:
Cost:	\$ 20,387.20
Prior Year Cost:	N/A
Terms: (Annual, Multi-Year, One-Time): One-Time	

Month:(board meeting) September 2025 **Budget Administrator** Caleb Clements **Date** 8/25/2025

26010 - Fertilizer		GRASS PAD INC.				Reinders, Inc			Harrell's, LLC												
Line Item	Quantity	Description	Unit Cost	Unit Measure (1,000# Super Sacks)	Extended Price	Additional Information	Unit Cost	Unit Measure (1,000# Super Sacks)	Extended Price	Unit Cost	Unit Measure (1,000# Super Sacks)	Extended Price	Additional Information								
19		15-5-15 Turf Fertilizer with Polymer Coated Urea	\$ 539.00	1000#			\$ 648.00	1000lb/Tote	\$12,312.00	\$ 614.25	1000lb sack	\$11,670.75	On the 15-5-15 Total Nitrogen (N)..... 15.0% 2.805% Ammoniacal Nitrogen 12.006% Urea Nitrogen* 0.189% Water Insoluble Nitrogen Available Phosphate (P2O5) 5.00% Soluble Potash (K2O) 15.00% Sulfur (S) 6.220% 6.220% Combined Sulfur Boron (B) 0.290% Copper (Cu) 0.290% Iron (Fe) 1.810% Manganese (Mn) 0.720% Molybdenum (Mo) 0.007% Zinc (Zn) 0.670% DERIVED FROM: Polymer Coated Urea Ammonium Sulfate Diammonium Phosphate Sulfate of Potash Sodium Borate Copper Oxide Copper Sulfate Iron Oxide Ferrous Sulfate Manganese Oxide Manganese Sulfate Molybdic Oxide Zinc Oxide Zinc Sulfate and Activated Sewage *12.000% Slowly available urea nitrogen from Polymer Coated Urea. ALSO CONTAINS NON-PLANT FOOD INGREDIENTS: Soil Amending Ingredients 7.00% Humic Acid (derived from Leonardite) 93.00% Total Other Ingredients (including nutrients) Purpose: May aid in the uptake of micronutrients (15000 lbs. Total)								On the 15-5-15 200lbs of micro mix per ton which resulted in the following: 8.62% S .13% B .27% Cu 53%Fe .27% Mn .003% Mo .27% Zn No Humic Acid. Total Nitrogen (N)..... 15.0% 2.676% Ammoniacal Nitrogen 0.081% Other/Water-Soluble Nitrogen 11.523% Urea Nitrogen* 0.72% Water Insoluble Nitrogen Available Phosphate (P2O5)..... 5.0% Soluble Potash (K2O)..... 15.0% Sulfur (S) 6.3% 6.3% Combined Sulfur (S) Boron (B) 0.28% Copper (Cu) 0.28% Iron (Fe) 1.93% Manganese (Mn) 0.72% Zinc (Zn) 0.67% Derived From: Ammonium Phosphate, Biosolids, Polymer Coated Urea, Sulfate of Ammonia, Sulfate of Potash, Copper Oxide, Ferric Oxide, Manganous Oxide, Sodium Borate, Zinc Oxide * 11.52% coated slow release Nitrogen (N) from Polymer Coated Urea NOTICE - Product contains Boron(B). Do not apply to Boron sensitive crops. Chlorine (Cl), Not more than..... 0.3% F352 Density - 61lb./cu. ft.
16		24-00-24 Turf Fertilizer with Polymer Coated Urea	\$ 504.70	1000#	\$8,075.20	Same	\$ 595.00	1000lb/Tote	\$8,925.00	\$ 620.06	1000lb sack	\$9,300.90									
2		Total Nitrogen (N) 24.00% 24.000% Urea Nitrogen* Soluble Potash (K2O) 24.00% Sulfur (S) 4.080% 4.080% Combined Sulfur DERIVED FROM: Urea Polymer Coated Urea Muriate of Potash and Sulfate of Potash. *14.400% Slowly available urea nitrogen from Polymer Coated Urea. (15000 lbs. Total)																			
Bid Totals:					\$17,811.50				\$21,237.00			\$20,971.65									
Awarded Totals:			\$20,387.20		\$8,075.20				\$12,312.00												
			GRASS PAD INC.			Reinders, Inc			Harrell's, LLC												
Can you meet the specifications? Please explain any exceptions.			Yes, With a difference in % of the Micro Mix, with "No Humic			Yes			Yes we can meet specifications, see attached labels												
Do you have the ability to delivery by September 30, 2025?			Yes			Yes			Yes												
All product will be ordered on one purchase order. Prefer the ability to offload using a forklift or something similar into warehouse. Can you meet these delivery requirements?			Yes			Yes			Yes												



PURCHASING UNIVERSAL REQUEST

BLUE VALLEY SCHOOL DISTRICT #229

Department/Bldg.:	Grounds	Requested By:	Caleb Clements
Purpose: (please explain in detail why we need the items or services requested)			
Purchase of new grounds tractor.			
Fund:	Capital Outlay	Account Number:	34765
Funding Year:	2025/2026	Location(s) items or services are for:	SSC
Does this use Bond Funds? (if yes, see below)		No	
<input type="checkbox"/> This request includes extended warranty, service or maintenance. Please complete the <u>Bond Warranty Agreement Form on page 2</u>		<input type="checkbox"/> This request includes training or consultation. Please complete <u>Bond Consultant Services Form on Page 3</u>	

Check all that apply to this Purchase:

- | | |
|--|--|
| <input type="checkbox"/> This is a New Contract | <input checked="" type="checkbox"/> This is a New Bid/RFP |
| <input type="checkbox"/> This is a Renewal Contract | <input checked="" type="checkbox"/> This is a Purchase from Bid/RFP # <u>26011</u> |
| <input type="checkbox"/> This is a Curriculum purchase | <input type="checkbox"/> This Purchase requires BOE Signatures |
| <input type="checkbox"/> This can be purchased off of _____ Contract # _____ | |

Begin Date: 9/8/2025	End Date: 3/31/2025
Company: Coleman Equipment, Inc.	Street Address: 24000 W 43rd Street
Contact Name: Aaron Skaggs	City: Shawnee
Telephone: (913) 422-3040	State: KS
Email: askaggs@colemanequip.com	Zip Code: 66226
Cost:	\$ 53,600.00
Prior Year Cost:	N/A
Terms: (Annual, Multi-Year, One-Time): One-Time	

Month:(board meeting) September 2025 **Budget Administrator** Jake Slabodnik **Date** 8/25/2025

26011 - Utility Cab Tractor																												
		Coleman Equipment, Inc.					McConnell Machinery Co.				KanEquip, Inc.				Romans Outdoor Power					Pereira Sales Company, Inc.								
Line Item	Description	Quantity	Manufacturer	Model	Unit Cost	Extended Cost	Additional Information	Manufacturer	Model	Unit Cost	Extended Cost	Manufacturer	Model	Unit Cost	Extended Cost	Manufacturer	Model	Unit Cost	Extended Cost	Additional Information	Manufacturer	Model	Unit Cost	Extended Cost	Additional Information			
1	New Kubota Tractor M4-071HDC12 Kubota V3307 Direct Injection 3.3L (203 cu. in.) 4 Cyl EPA Tier 4 Emission Certified SAE Gross HP:74.3 Engine Net HP: 68.7 Max . PTO HP: 60 Common Rail Electronic Fuel Electronic Engine Management Constant RPM Management Turbocharged 130 Amp Alternator 12V 900 CCA Battery CAB (Ultra Grand Cab Category II) Front Tires - 9.50-24 R3 All Weather TI Rear Tires - 18.4-26 R3 (ANS) 17mm Holes ADD ONS: Creep Speed Kit Flow Control+SCD Valve 2nd Position Lever Kit with Float Detent Valve 3rd Position Lever Kit with Float Detent Valve Front Weight Bumper 10 Weight Max Bolt Kit- bumper Air Ride Seat Suspension Upgrade Kit MS Air Ride Seat Wiring Harness PNF Rear Window Wiper Kit w/ Washer Rear Window Defogger Kit M4 Inside Mirror Kit for MS Cab Tractor PNF External 3PT Controller Kit M4 Kubota NOW Telematics Grille Guard Kit Front Suitcase Weight	1	Kubota	M4-071HDC12	\$ 53,600.00	\$53,600.00		Kubota	M4-071HDC12	\$ 55,600.0000	\$55,600.00	NEW HOLLAND	WORKMASTER 75	\$ 60,081.15	\$60,081.15	Kubota	M4-071HDC12	\$ 64,913.00	\$64,913.00		Kubota	M4-071HDC12	\$ 72,990.92	\$72,990.92				PLEASE NOTE: this is the UNIT COST. It does not include the 2YR warranty price listed below.
2	Provide optional 2 year extended warranty price		2 Year Extended Warranty	2 Year or 4000 Hour	\$ 2,500.00		2500 additional for the extended warranty.	Kubota	2-Year	\$ 2,500.0000		NEW HOLLAND	2 YR EXT WARRANTY	\$ 3,181.00		Kubota	2 year ext. warranty	\$ 2,500.00		4000 hours max coverage	Orange Protection Program	M4-2YR	\$ 2,500.00				PLEASE NOTE: This is not included in the unit price of the Kubota tractor. Subtotal should be 75490.92	
Totals:					\$53,600.00					\$55,600.00				\$60,081.15				\$64,913.00						\$72,990.92				
		Coleman Equipment, Inc.					McConnell Machinery Co.				KanEquip, Inc.				Romans Outdoor Power					Pereira Sales Company, Inc.								
Describe the standard warranty period and what is covered. Describe how we submit a warranty claim and include who would perform warranty repairs		Basic Standard Limited - 24 Months or 2000 Hours (whichever occurs first) Limited Powertrain - 36 Months or 3000 Hours (whichever occurs first) You will contact your local Coleman Equipment dealership for warranty submission and repairs.					Basic Standard Limited 24 Months or 2000 Hours (whichever occurs first) Limited Powertrain 36 Months or 3000 Hours (whichever occurs first) Contact our service department and they will submit the warranty claim and perform the warranty repairs.				The warranty is 2 year/2,000 hour which ever comes first. It is a full bumper to bumper warranty that covers any manufacture defects. If there is a warranty issue, Blue Valley would call us and we would come pick the tractor up, come on site with our service truck, or Blue Valley could arrange to haul it in. Warranty will NOT pay for hauling or the trip charge for the service truck. One of my New Holland certified technicians will perform the warranty repairs				3 year total warranty coverage. ie; first 2 years bumper to bumper; then last 3rd year powertrain only. Only dealers will submit a warranty claim. Romans can and will perform warranty work.					2 year / 2000 hours								
Does your bid meet minimum requirements? Please describe any deviations.		Yes it meets the bid requirements.					Yes				Yes				yes.					Yes								
Must be able to deliver to Blue Valley USD 229 Grounds Department, 7484 W. 149th Terrace, Overland Park 66223. Provide training/overview of tractor upon delivery. Can you meet this requirement?		Yes					Yes				Yes. I (the salesman) will deliver the tractor or come with the truck driver to provide a walk around and training.				We will deliver to the address you provided at no cost. And give a brief overview of the tractor.					Yes								
Service location must be within a 50 mile radius of Blue Valley USD 229. Can you meet this requirement? Please describe your service location.		Yes, 24000 W 43rd Street, Shawnee, KS 66226					Yes				The Topeka location is located 71 miles from the district office. The Ottawa location is located 43 Miles from the district office. Service repairs can be done at Ottawa. Warranty repairs would have to be done at the Topeka location. The Ottawa location is not a New Holland dealer but would be able to work on the tractor				Yes. Louisburg, KS.					No- Local dealer can perform.								



PURCHASING UNIVERSAL REQUEST

BLUE VALLEY SCHOOL DISTRICT #229

Department/Bldg.:	Facility & Operations	Requested By:	Andy Spruill
Purpose: (please explain in detail why we need the items or services requested)			
Purchase of three maintenance vehicles.			
Fund:	Capital Outlay	Account Number:	016000460-7027
Funding Year:		Location(s) items or services are for:	SSC
Does this use Bond Funds? (if yes, see below)		No	
<input type="checkbox"/> This request includes extended warranty, service or maintenance. Please complete the <u>Bond Warranty Agreement Form on page 2</u>		<input type="checkbox"/> This request includes training or consultation. Please complete <u>Bond Consultant Services Form on Page 3</u>	

Check all that apply to this Purchase:

- | | |
|--|--|
| <input type="checkbox"/> This is a New Contract | <input checked="" type="checkbox"/> This is a New Bid/RFP |
| <input type="checkbox"/> This is a Renewal Contract | <input checked="" type="checkbox"/> This is a Purchase from Bid/RFP # <u>26012</u> |
| <input type="checkbox"/> This is a Curriculum purchase | <input type="checkbox"/> This Purchase requires BOE Signatures |
| <input type="checkbox"/> This can be purchased off of _____ Contract # _____ | |

Begin Date: 9/8/2025	End Date: 3/31/2026
Company: Shawnee Mission Ford Inc	Street Address: 11501 Shawnee Mission Parkway
Contact Name: Jay Cooper	City: Shawnee
Telephone: (913) 248-2287	State: KS
Email: jay.cooper@shawneemissionford.com	Zip Code: 66203
Cost:	\$ 207,549.00
Prior Year Cost:	N/A
Terms: (Annual, Multi-Year, One-Time): One-Time	

Month:(board meeting) September 2025 **Budget Administrator** Jake Slabodnik **Date** 8/25/2025

26012 - Transit Van

Line Item	Description	Quantity	Shawnee F LLC DBA Shawnee Mission Ford				OLATHE FORD SALESK, INC				Laird Noller Automotive Inc				Drivege Vehicle Innovations, LLC				ALAMEX INC				
			Year	Model	Unit Cost	Extended Cost	Year	Model	Unit Cost	Extended Cost	Year	Model	Unit Cost	Extended Cost	Year	Model	Unit Cost	Extended Cost	Additional Information (if necessary)	Year	Model	Unit Cost	Extended Cost
1	2026 Ford Transit Vans (High Roof) Upfitting to include: General Contractor trade package, cargo lighting, hard rubber flooring, 3-bar double drop down ladder racks. Plus four extra keys	3	2026	Ford Transit T350 HR AWD 148 WB	\$ 69,183.00	\$207,549.00	26	Transit	\$ 67,010.00	\$201,030.00	2026	Transit	\$ 70,239.00000	\$210,717.00	2026	Ford Transit F6X 350 Hi Roof LWB Cargo AWD	\$ 70,941.00	\$212,823.00	per the issued addenda: The speed-limiting governor has been removed from required specification	2026	Ford T350HD High Roof Long Wheelbase	\$ 74,616.00	\$223,848.00
Totals:					\$207,549.00		Did not include upfit		\$201,030.00				\$210,717.00				\$212,823.00					\$223,848.00	



PURCHASING UNIVERSAL REQUEST

BLUE VALLEY SCHOOL DISTRICT #229

Department/Bldg.:	CTE	Requested By:	Adam Wessel
Purpose: (please explain in detail why we need the items or services requested)			
these are items from PLTW to support the Honors Principles of Engineering at BVW, a new course offering for 25-26 school year			
Fund:	Capital Outlay	Account Number:	034000114-6038
Funding Year:	2025-2026	Location(s) items or services are for:	Blue Valley West
Does this use Bond Funds? (if yes, see below)			
<input type="checkbox"/> This request includes extended warranty, service or maintenance. Please complete the <u>Bond Warranty Agreement Form on page 2</u>		<input type="checkbox"/> This request includes training or consultation. Please complete <u>Bond Consultant Services Form on Page 3</u>	

Check all that apply to this Purchase:

- | | |
|--|--|
| <input checked="" type="checkbox"/> This is a New Contract | <input checked="" type="checkbox"/> This is a New Bid/RFP |
| <input type="checkbox"/> This is a Renewal Contract | <input checked="" type="checkbox"/> This is a Purchase from Bid/RFP # <u>26013</u> |
| <input type="checkbox"/> This is a Curriculum purchase | <input type="checkbox"/> This Purchase requires BOE Signatures |
| <input type="checkbox"/> This can be purchased off of _____ Contract # _____ | |

Begin Date: 9-1-25	End Date: NA
Company: PLTW	Street Address: 5939 Castle Creek Parkway North Drive
Contact Name: NA	City: Indianapolis
Telephone: 877-335-PLTW	State: Indiana
Email:	Zip Code: 46250
Cost: 32,466.80	
Prior Year Cost: NA	
Terms: (Annual, Multi-Year, One-Time): <u>one-time</u>	

Month:(board meeting) September 2025 **Budget Administrator** Adam Wessel **Date** 8/25/2025

26013 - Engineering Classroom Supplies					Project Lead The Way, Inc.		
Line Item	Location	Description	Quantity	Manufacturer Model	Vendor Part		
				No.	No.	Unit Price	Extended Price
1	BVW	Beakers 600 mL 6 pack	3	470149-356		\$ 29.50	\$88.50
2	BVW	Funnel Set 5x small and 5x large	2	44PWEE564		\$ 33.00	\$66.00
3	BVW	Golf Balls 12 pack	1	44PWEE574		\$ 18.50	\$18.50
4	BVW	Plastic Flex Tubing for 10mL Syringes 100 ft	1	44PWEE576		\$ 20.20	\$20.20
5	BVW	Rubber Bands 1/4 lb Assorted	2	470149-734		\$ 4.80	\$9.60
6	BVW	Solenoid 12v with Male Pins 10 pack	1	44PWEE578		\$ 59.00	\$59.00
7	BVW	Vernier Go Direct Wireless Force and Acceleration Sensor	6	GDX-FOR		\$ 127.50	\$765.00
8	BVW	270-7921 Vex V5 POE/CIM CUSTOM KIT	12	270-7921		\$ 2,620.00	\$31,440.00
Total:							\$32,466.80



PURCHASING UNIVERSAL REQUEST

BLUE VALLEY SCHOOL DISTRICT #229

Department/Bldg.:	Academic Services	Requested By:	Adam Wessel
Purpose: (please explain in detail why we need the items or services requested)			
This purchase is for new 3D printers for all our HS industrial tech programs and carbon fiber for use with printers.			
Fund:	Capital Outlay	Account Number:	
Funding Year:		Location(s) items or services are for:	High Schools
Does this use Bond Funds? (if yes, see below)			
<input type="checkbox"/> This request includes extended warranty, service or maintenance. Please complete the <u>Bond Warranty Agreement Form on page 2</u>		<input type="checkbox"/> This request includes training or consultation. Please complete <u>Bond Consultant Services Form on Page 3</u>	

Check all that apply to this Purchase:

- | | |
|--|--|
| <input type="checkbox"/> This is a New Contract | <input checked="" type="checkbox"/> This is a New Bid/RFP |
| <input type="checkbox"/> This is a Renewal Contract | <input checked="" type="checkbox"/> This is a Purchase from Bid/RFP # <u>26014</u> |
| <input type="checkbox"/> This is a Curriculum purchase | <input type="checkbox"/> This Purchase requires BOE Signatures |
| <input type="checkbox"/> This can be purchased off of _____ Contract # _____ | |

Begin Date: 8/9/2025	End Date: 12/31/2025
Company: Staples, Inc.	Street Address: PO Box 95230
Contact Name: Chris Pappas	City: Chicago
Telephone: (407) 475-4523	State: IL
Email: christopher.pappas@staples.com	Zip Code: 60694
Cost:	\$ 27,752.55
Prior Year Cost:	
Terms: (Annual, Multi-Year, One-Time): One-Time	

Month:(board meeting) September 2025 **Budget Administrator** Adam Wessel **Date** 9/3/2025

26014 - 3D Printers

		Staples Inc.				Best Buy Stores, L.P.			Aztek Computers LLC			DEPCO Enterprises LLC			
<u>Line</u> <u>Item</u>	<u>Item Description</u>	<u>Quantity</u>	<u>Unit Cost</u>	<u>Total Cost</u>	<u>Vendor</u> <u>Model No.</u>	<u>Unit Cost</u>	<u>Total Cost</u>	<u>Vendor</u> <u>Model No.</u>	<u>Unit Cost</u>	<u>Total Cost</u>	<u>Vendor</u> <u>Model No.</u>	<u>Unit Cost</u>	<u>Total Cost</u>	<u>Vendor Model</u> <u>No.</u>	<u>Additional</u> <u>Information</u>
1	3D Printers Preferred: Ultimaker S5 3D model Product No. 218252 or Equal	7	\$ 3,026.52	\$21,185.64	218252	\$ 3,072.59	\$21,508.13	218252	\$ 4,572.17	\$32,005.19	218252	\$ 4,999.00	\$34,993.00	Ultimaker S5	This matches the Promo price that Ultimaker is currently offering
2	Carbon Fiber Expansion Kit Preferred: Ultimaker PET	7	\$ 938.13	\$6,566.91	235438	\$ 911.4700	\$6,380.29	235438	\$ 1,128.00	\$7,896.00	235438	\$ 1,025.00	\$7,175.00	PETCF Bundle Model# 235438	This is current pricing
Totals:			\$27,752.55					\$27,888.42			\$39,901.19			\$42,168.00	

		3D Universe, LLC			JAG TECH ENTERPRISES LLC			E-LOGIC			Beckatt Solutions, LLC			
<u>Line</u> <u>Item</u>	<u>Item Description</u>	<u>Quantity</u>	<u>Unit Cost</u>	<u>Total Cost</u>	<u>Vendor</u> <u>Model No.</u>	<u>Unit Cost</u>	<u>Total Cost</u>	<u>Vendor</u> <u>Model No.</u>	<u>Unit Cost</u>	<u>Total Cost</u>	<u>Vendor</u> <u>Model No.</u>	<u>Unit Cost</u>	<u>Total Cost</u>	<u>Vendor Model</u> <u>No.</u>
1	3D Printers Preferred: Ultimaker S5 3D model Product No. 218252 or Equal	7	\$ 4,999.00	\$34,993.00	218252	\$ 5,248.95	\$36,742.65	#218252	\$ 5,908.79	\$41,361.53	218252	\$ 6,950.00	\$48,650.00	218252
2	Carbon Fiber Expansion Kit Preferred: Ultimaker PET	7	\$ 1,025.00	\$7,175.00	235438	\$ 1,076.26	\$7,533.82	#235438	\$ 1,228.02	\$8,596.14	235438	\$ 1,025.00	\$7,175.00	235438
Totals:				\$42,168.00			\$44,276.47			\$49,957.67			\$55,825.00	



PURCHASING UNIVERSAL REQUEST

BLUE VALLEY SCHOOL DISTRICT #229

Department/Bldg.:	Custodial Dept	Requested By:	Matt Brooks
Purpose: (please explain in detail why we need the items or services requested)			
Yearly gym floor maintenance coat for the east half of the district.			
Fund:	Capital Outlay ▼	Account Number:	23999
Funding Year:	2025/2026 ▼	Location(s) items or services are for:	East Half Gym Floors
Does this use Bond Funds? (if yes, see below)		No	
<input type="checkbox"/> This request includes extended warranty, service or maintenance. Please complete the <u>Bond Warranty Agreement Form on page 2</u>		<input type="checkbox"/> This request includes training or consultation. Please complete <u>Bond Consultant Services Form on Page 3</u>	

Check all that apply to this Purchase:

- | | |
|--|--|
| <input type="checkbox"/> This is a New Contract | <input type="checkbox"/> This is a New Bid/RFP |
| <input type="checkbox"/> This is a Renewal Contract | <input type="checkbox"/> This is a Purchase from Bid/RFP # _____ |
| <input type="checkbox"/> This is a Curriculum purchase | <input type="checkbox"/> This Purchase requires BOE Signatures |
| <input checked="" type="checkbox"/> This can be purchased off of TIPS | <input checked="" type="checkbox"/> Contract # #230103 |

OK NH 8/19/25

Begin Date: 11/7/2025	End Date: 3/21/2026
Company: 4J Facility Supply LLC	Street Address: 20475 Linwood Rd
Contact Name: Eric Johnson	City: Lindwood
Telephone: (913) 593-3667	State: ks
Email: ejohnson@4jfacilitiesupply.com	Zip Code: 66052
Cost: \$ 35,000.00 Estimated ▼	
Prior Year Cost: N/A - Not Availa ▼	
Terms: (Annual, Multi-Year, One-Time):	

Month:(board meeting) August 2025 **Budget Administrator** Matt Brooks **Date**8/19/2025

East half

DATE	LOCATION	FACILITY	REASON	EMS PERMIT #	Estimated Square Ft	NOTES/COMMENTS
3/13-3/21	BVA	Gym	Maintenance Coat		8,415	Reservation #115827
3/13-3/21	BVM	Gym	Maintenance Coat		9,316	Reservation #115809
3/13-3/21	LKM	Gym	Maintenance Coat		9,096	Reservation #115811
3/13-3/21	LMS	Gym	Maintenance Coat		8730	Reservation #115812
3/13-3/21	OTM	Gym	Maintenance Coat		8,415	Reservation #115815
3/13-3/21	PSM	Gym	Maintenance Coat		9,300	Reservation #115818
11/7-11/9	BVH	South Gym (new)	Maintenance Coat		13,191	Reservation #115833
XXXXXX	BVH	North Gym	No work			10,767
Dec 23-27	BVH	Aux Gym	Maintenance Coat		6,993	Reservation #115821
11/14-11/16	BVN	Main Gym	Maintenance Coat		14,190	Reservation #115842
Dec 23-27	BVN	Aux Gym (original)	Maintenance Coat		7,107	Reservation #115843
3/13-3/21	BVN	New Aux Gym	Maintenance Coat		10,000	Reservation #115844
XXXXXX	BVN	Commons Floor	No work			Not this year 1900
Cost per sqft					104,753	Total SqFt
\$ 0.315					\$ 32,997.20	Total Estimated Cost



PURCHASING UNIVERSAL REQUEST

BLUE VALLEY SCHOOL DISTRICT #229

Department/Bldg.:	ITS	Requested By:	Nathaniel Chipman
Purpose: (please explain in detail why we need the items or services requested)			
26-012 Hilltop Exterior Cameras This purchase will add cameras to the exterior of the Hilltop learning Center building.			
Fund:	Bond	Account Number:	40825700-0
Funding Year:	2025/2026	Location(s) items or services are for:	HLC
Does this use Bond Funds? (if yes, see below)		Yes	
<input type="checkbox"/> This request includes extended warranty, service or maintenance. Please complete the <u>Bond Warranty Agreement Form on page 2</u>		<input checked="" type="checkbox"/> This request includes training or consultation. Please complete <u>Bond Consultant Services Form on Page 3</u>	

Check all that apply to this Purchase:

- | | |
|--|--|
| <input type="checkbox"/> This is a New Contract | <input type="checkbox"/> This is a New Bid/RFP |
| <input type="checkbox"/> This is a Renewal Contract | <input type="checkbox"/> This is a Purchase from Bid/RFP # _____ |
| <input type="checkbox"/> This is a Curriculum purchase | <input type="checkbox"/> This Purchase requires BOE Signatures |
| <input checked="" type="checkbox"/> This can be purchased off of TIPS | Contract # 240101 |
| | OK NH 8/25/25 |

Begin Date: 9/10/2025	End Date: 12/31/2025
Company: American Digital Security LLC	Street Address: 140 Westwoods Dr.
Contact Name: Rob Behrens	City: Liberty
Telephone: (816) 415-4237	State: MO
Email: rob@securitybyads.com	Zip Code: 64068
Cost: \$ 28,643.49 Estimated	
Prior Year Cost:	
Terms: (Annual, Multi-Year, One-Time): One-Time	

Month:(board meeting) September 2025 **Budget Administrator** Brian Daley **Date** 8/25/2025

Only complete this page if this is a Bond Fund Purchase



**DESCRIPTION OF CONSULTANT SERVICES
PROVIDED FROM CAPITAL (BOND)
EXPENDITURE FUNDS**

Service to be provided by:

Business name: American Digital Security

Address: 140 Westwoods Dr. Liberty MO 64068

Please give a detailed description of the services being provided:

25-110 ES Pod Cameras

This purchase will upgrade cameras to the exterior of the Hilltop learning Center building.

Budget manager signature *Brian Daley*

Bid or RFP number, if applicable _____

Bond compliance use:

Capital expenditure approved?	Date	Signature/Initials



American Digital Security
 140 Westwoods Dr.
 Liberty MO 64068
 United States
 (816) 415-4237

Estimate

#EST0018307

07/31/2025

Bill To

Nate Chipman / 2501980
 Blue Valley Schools
 14950 Metcalf Avenue
 Overland Park KS 66223-
 United States

Ship To

Hilltop Campus
 7700 W 143rd Street
 Shawnee Mission KS 66223
 United States

TOTAL

\$28,643.49

Expires: 09/14/2025

Terms	Expires	PO #	Sales Rep	Title	Memo
Due on receipt	09/14/2025		Rob E Behrens	Hilltop Exterior Cameras Upgrade	TIPS CONTRACT #240101

Quantity	Item	Options	Rate	Amount
3	32C-H5A-4MH H5A Multisensor 32MP Camera Module 3.3-5.7mm		\$2,691.10	\$8,073.30
1	24C-H5A-3MH H5A Multisensor 24MP Camera Module 3.3-5.7mm		\$2,253.35	\$2,253.35
2	8.0C-H6A-DO1-IR 8MP H6A Outdoor IR Dome Camera with 4.4-9.3mm Lens		\$1,569.71	\$3,139.42
2	16.0C-H6ADH-DO1-IR 2x 8MP H6A Dual Head Outdoor Camera		\$1,827.50	\$3,655.00
4	WLMT-1001 Wall Mount for large pendant camera		\$111.61	\$446.44
4	H5AMH-AD-PEND1 Outdoor pendant mount adapter		\$169.39	\$677.56
4	H5AMH-DO-COVR1 Dome bubble and cover; for outdoor surface mount or pendant mount; clear		\$169.39	\$677.56
4	H4AMH-AD-IRIL1 IR Illuminator Ring for H4 Multisensor		\$330.99	\$1,323.96
4	POE60U-1BTE Gigabit 802.3bt 60 W PoE Injector		\$150.45	\$601.80
3	CRNMT-1001 CORNER MNT FOR LRGE PENDT WLMT-1001		\$133.40	\$400.20
2	NPTA-1201 1.5 inch NPT Adapter for Dual Head Cameras		\$59.50	\$119.00
4	WLMT-1021 Mount; Pendant Arm; 20cm Long; 1.5 NPT		\$89.25	\$357.00
2	H6A-MT-NPTA1 Pendant adapter; NPT; H6A		\$51.00	\$102.00
15	LT-FLEX-NM-1/2-CUT-REEL Non-Metallic Per Foot		\$1.06	\$15.90
500	CAT6P-GRN 23-4P UNS SOL CMP C6 Grn Jkt		\$0.47	\$235.00



EST0018307



American Digital Security
 140 Westwoods Dr.
 Liberty MO 64068
 United States
 (816) 415-4237

Estimate

#EST0018307

07/31/2025

Quantity	Item	Options	Rate	Amount
1	Project Engineering		\$125.00	\$125.00
1	Hardware100		\$100.00	\$100.00
40	ADSLABOR Installation		\$130.00	\$5,200.00
4	ADSPROJECTMANAGEMENT		\$145.00	\$580.00
1	Shipping and Handling Charge		\$561.00	\$561.00

Subtotal	\$28,643.49
Tax Total (\$)	\$0.00
Total	\$28,643.49



EST0018307



PURCHASING UNIVERSAL REQUEST

BLUE VALLEY SCHOOL DISTRICT #229

Department/Bldg.:	Custodial Services	Requested By:	Matthew Brooks
Purpose: (please explain in detail why we need the items or services requested)			
This request is to purchase 10 new Kaivac machines for restroom cleaning.			
Fund:	Capital Outlay	Account Number:	23963
Funding Year:	2025/2026	Location(s) items or services are for:	Middle schools
Does this use Bond Funds? (if yes, see below)		No	
<input type="checkbox"/> This request includes extended warranty, service or maintenance. Please complete the <u>Bond Warranty Agreement Form on page 2</u>		<input type="checkbox"/> This request includes training or consultation. Please complete <u>Bond Consultant Services Form on Page 3</u>	

Check all that apply to this Purchase:

- | | |
|---|--|
| <input type="checkbox"/> This is a New Contract | <input type="checkbox"/> This is a New Bid/RFP |
| <input type="checkbox"/> This is a Renewal Contract | <input type="checkbox"/> This is a Purchase from Bid # _____ |
| <input type="checkbox"/> This is a Curriculum purchase | <input type="checkbox"/> This Purchase requires BOE Signatures |
| <input checked="" type="checkbox"/> This can be purchased off of Greenbush | Contract # 24.7 ESC-Facility Solutions2024 |
- Contract verified 8/26/2025 tlv

Begin Date: 7/1/2025	End Date: 6/30/2026
Company: Brady Industries of Kansas LLC	Street Address: 1200 N Erie
Contact Name: Jill Ward	City: Kansas City
Telephone: (316) 214-3616	State: MO
Email: jill.ward@bradyplus.com	Zip Code: 64116
Cost: \$ 44,429.50 Estimated	
Prior Year Cost: 0 Estimated	
Terms: (Annual, Multi-Year, One-Time): Annual	

Month:(board meeting) September 2025 **Budget Administrator** Matt Brooks **Date** 8/22/25



(Formerly BradyIFS)

Wichita, KS
 Phone: 316-942-9494
 BradyPLUS.com

QUOTATION

#9709754

8/22/2025

Quote Expires On: 10/21/2025

ORDERED BY: BLUE VALLEY SCHOOL DISTRICT
 P O BOX 23901
 OVERLAND PARK, KS 66283-0901
 USA

SHIP TO: BLUE VALLEY WAREHOUSE
 7480 W 149th Ter
 Overland Park, KS 66223-2240
 US

Customer ID: 238284	Ship To ID: 241534
Order #: 9709754	Entered By: JILL.WARD
Customer PO #:	

Qty	B/O	Item ID	Description	UoM	Unit Price	Ext Price
<p>Order Note: Pricing based off Green Bush Coop 24.7 ESC-Facility Solutions2024</p> <p>Delivery Instructions: ***PLEASE CALL ROCKY DEANGELO 816-217-8727 BEFORE DELIVERY ***</p> <p>PULL UP TO GARAGE DOORS, GO IN DOOR ON FAR LEFT OF BUILDING. SOMEBODY INSIDE WILL TELL YOU WHERE TO DROP.</p>						
10.00	10.00	KL-577535	VERSA 17 GAL 500 PSI 120VAC CORDED	EACH	4,442.950	44,429.50
6.00	6.00	PT107783	GOFIT 6 4AH XOVER 2-PC WAND	EACH	863.000	5,178.00
10.00	10.00	PT-107683	GOFIT CORDLESS 4AH BATTERY	EACH	399.000	3,990.00
FUEL:						0.00

SUB-TOTAL:		53,597.50
TAX:		0.00
BALANCE DUE:		53,597.50
<i>Total Lines:</i>		



PURCHASING UNIVERSAL REQUEST

BLUE VALLEY SCHOOL DISTRICT #229

Department/Bldg.:	ITS	Requested By:	John Yates
Purpose: (please explain in detail why we need the items or services requested)			
<p>26-013 Network Switches Purpose; This purchase of network equipment will support the paging replacement project in the elementary schools.</p>			
Fund:	Bond	Account Number:	44110734-0
Funding Year:	2025/2026	Location(s) items or services are for:	District Wide
Does this use Bond Funds? (if yes, see below)		Yes	
<input type="checkbox"/> This request includes extended warranty, service or maintenance. Please complete the <u>Bond Warranty Agreement Form on page 2</u>		<input type="checkbox"/> This request includes training or consultation. Please complete <u>Bond Consultant Services Form on Page 3</u>	

Check all that apply to this Purchase:

- | | |
|--|--|
| <input type="checkbox"/> This is a New Contract | <input type="checkbox"/> This is a New Bid/RFP |
| <input type="checkbox"/> This is a Renewal Contract | <input type="checkbox"/> This is a Purchase from Bid/RFP # _____ |
| <input type="checkbox"/> This is a Curriculum purchase | <input type="checkbox"/> This Purchase requires BOE Signatures |
| <input checked="" type="checkbox"/> This can be purchased off of Greenbush Contract # 022-G
Contract verified 8/26/2025 tlv | |

Begin Date: 8/16/2025	End Date: 8/15/2026
Company: CDW Government Inc	Street Address: 75 Remittance Drive, Suite 1515
Contact Name: Brendan Devlieger	City: Chicago
Telephone: (866) 684-4536	State: IL
Email: brendev@cdwg.com	Zip Code: 60675-1515
Cost: \$ 83,080.00	
Prior Year Cost:	
Terms: (Annual, Multi-Year, One-Time): One-Time	

Month:(board meeting) September 2025 **Budget Administrator** Brian Daley **Date** 8/25/2025



Thank you for choosing CDW. We have received your quote.

QUOTE CONFIRMATION

JOHN YATES,

Thank you for considering CDW•G for your technology needs. The details of your quote are below. **If you are an eProcurement or single sign on customer, please log into your system to access the CDW site.** You can search for your quote to retrieve and transfer back into your system for processing.

For all other customers, click below to convert your quote to an order.

Convert Quote to Order

QUOTE #	QUOTE DATE	QUOTE REFERENCE	CUSTOMER #	GRAND TOTAL
PNLT701	8/5/2025	3400S	1685938	\$83,080.00

QUOTE DETAILS				
ITEM	QTY	CDW#	UNIT PRICE	EXT. PRICE
Juniper EX3400 48 Ports Compact Access Ethernet Switch	40	4111095	\$2,077.00	\$83,080.00
Mfg. Part#: EX3400-48P UNSPSC: 43222612 advertised: 6978.50 greenbush: 6559.79 Contract: SEKESC Blue Valley School District (022-G)				

SUBTOTAL	\$83,080.00
SHIPPING	\$0.00
SALES TAX	\$0.00
GRAND TOTAL	\$83,080.00

PURCHASER BILLING INFO	DELIVER TO
Billing Address: BLUE VALLEY SCHOOL DISTRICT ACCTS PAYABLE PO BOX 23901 OVERLAND PARK, KS 66283-0901 Phone: (913) 681-4000 Payment Terms: NET 30 Days-Govt/Ed	Shipping Address: BLUE VALLEY SCHOOL DISTRICT JOHN YATES 7490 W 149TH TER OVERLAND PARK, KS 66223-2240 Shipping Method: DROP SHIP-GROUND
Please remit payments to:	
CDW Government 75 Remittance Drive Suite 1515 Chicago, IL 60675-1515	



Sales Contact Info

Brendan Devlieger | (866) 684-4534 | brendev@cdwg.com

Need Help?



My Account



Support



Call 800.800.4239

[About Us](#) | [Privacy Policy](#) | [Terms and Conditions](#)

This order is subject to CDW's Terms and Conditions of Sales and Service Projects at

<http://www.cdwg.com/content/terms-conditions/product-sales.aspx>

For more information, contact a CDW account manager.

© 2025 CDW•G LLC, 200 N. Milwaukee Avenue, Vernon Hills, IL 60061 | 800.808.4239



PURCHASING UNIVERSAL REQUEST

BLUE VALLEY SCHOOL DISTRICT #229

Department/Bldg.:	Facilities and Operations	Requested By:	Caleb Clements
Purpose: (please explain in detail why we need the items or services requested)			
Landscaping and Athletic Field Services			
Fund:	Capital Outlay ▼	Account Number:	32897
Funding Year:	2025/2026 ▼	Location(s) items or services are for:	District Wide
Does this use Bond Funds? (if yes, see below)			
<input type="checkbox"/> This request includes extended warranty, service or maintenance. Please complete the <u>Bond Warranty Agreement Form on page 2</u>		<input type="checkbox"/> This request includes training or consultation. Please complete <u>Bond Consultant Services Form on Page 3</u>	

Check all that apply to this Purchase:

- | | |
|---|---|
| <input type="checkbox"/> This is a New Contract | <input type="checkbox"/> This is a New Bid/RFP |
| <input type="checkbox"/> This is a Renewal Contract | <input type="checkbox"/> This is a Purchase from Bid/RFP # _____ |
| <input type="checkbox"/> This is a Curriculum purchase | <input type="checkbox"/> This Purchase requires BOE Signatures |
| <input checked="" type="checkbox"/> This can be purchased off of Greenbush | <input checked="" type="checkbox"/> Contract # 25.4 ESC-lawngroundsmaint2025 |

Begin Date: 9/2/2025	End Date: 6/30/2026
Company: Goodwin Pro Turf Inc	Street Address: 6945 W. 152nd Terrace
Contact Name: Steve Goodwin	City: Overland Park
Telephone: (913) 685-1000	State: KS
Email: Steve@goodwinproturf.com	Zip Code: 66223
Cost: \$ 450,000.00 Estimated	▼
Prior Year Cost:	
Terms: (Annual, Multi-Year, One-Time):	

Month:(board meeting) September 2025 **Budget Administrator** Jake Slabodnik **Date**8/27/2025



PURCHASING UNIVERSAL REQUEST

BLUE VALLEY SCHOOL DISTRICT #229

Department/Bldg.:	Custodial Dept	Requested By:	Matt Brooks
Purpose: (please explain in detail why we need the items or services requested)			
Yearly gym floor maintenance coat for the west half of the district.			
Fund:	Capital Outlay ▼	Account Number:	23999
Funding Year:	2025/2026 ▼	Location(s) items or services are for:	West Half Gym Floors
Does this use Bond Funds? (if yes, see below)		No	
<input type="checkbox"/> This request includes extended warranty, service or maintenance. Please complete the <u>Bond Warranty Agreement Form on page 2</u>		<input type="checkbox"/> This request includes training or consultation. Please complete <u>Bond Consultant Services Form on Page 3</u>	

Check all that apply to this Purchase:

- | | |
|--|--|
| <input type="checkbox"/> This is a New Contract | <input type="checkbox"/> This is a New Bid/RFP |
| <input type="checkbox"/> This is a Renewal Contract | <input type="checkbox"/> This is a Purchase from Bid/RFP # _____ |
| <input type="checkbox"/> This is a Curriculum purchase | <input type="checkbox"/> This Purchase requires BOE Signatures |
| <input checked="" type="checkbox"/> This can be purchased off of TIPS | <input checked="" type="checkbox"/> Contract # #230103 |

OK NH 8/19/25

Begin Date: 11/7/2025	End Date: 3/21/2026
Company: Hillyard Kansas City	Street Address: 10809 N Pomona
Contact Name: Jon Woelk	City: Kansas City
Telephone: (913) 579-2344	State: MO
Email: jwoelk@hillyard.com	Zip Code: 64153
Cost: \$ 35,000.00 Estimated ▼	
Prior Year Cost: \$75,000.00 Estimated ▼	
Terms: (Annual, Multi-Year, One-Time): One-Time	

Month:(board meeting) August 2025 **Budget Administrator** Matt Brooks **Date**8/19/2025



Hillyard Kansas City NWMO

10809 North Pomona

Kansas City, MO 64153

www.hillyard.com

tel: 888.420.7380

fax: 816.569.0909

Wednesday, July 16th, 2025

Matthew Brooks,

Hillyard will be utilizing the TIPS GPO for our gym floor bid this year. TIPS Contract #230103 specifies a 15% discount from .55 per square foot for screen and 1 coat of Trophy H2O. Which would be .46 cents per square foot. Due to the volume and competitive nature of this bid Hillyard is providing screen and recoat services at .32 cents.

We appreciate the opportunity to work with Blue Valley School District.

Thank you,

Jon Woelk
Hillyard KC
913-579-2344
Jwoelk@hillyard.com

West Half

DATE	LOCATION	FACILITY	REASON	EMS PERMIT #	Estimated Square Ft	NOTES/COMMENTS
3/13-3/21	ABM	Gym	Maintenance Coat		10,715	Reservation #115807 (main gym only)
3/13-3/21	HMS	Gym	Maintenance Coat		8,316	Reservation #115810
3/13-3/21	OMS	Gym	Maintenance Coat		8,450	Reservation #115814
3/13-3/21	OTM	Gym	Maintenance Coat		8,415	Reservation #115815
3/13-3/21	PRM	Gym	Maintenance Coat		8,750	
3/13-3/21	STI	Gym	Maintenance Coat		4,290	Reservation #115819
11/14-11/16	BVNW	Main Gym (new)	Maintenance Coat		13,191	Reservation #115819
Dec 23-27	BVNW	Old Main Gym	Maintenance Coat		11,817	Reservation #115837
Dec 23-27	BVNW	Aux Gym	Maintenance Coat		7,236	Reservation #115837
11/7-11/9	BVSW	Main Gym	Maintenance Coat		14,136	Reservation #115855
11/7-11/9	BVSW	Aux Gym	Maintenance Coat		7,980	Reservation #115855
				Cost per sqft	103,296	Total SqFt
				\$ 0.32	\$ 33,054.72	Total Estimated Cost



PURCHASING UNIVERSAL REQUEST

BLUE VALLEY SCHOOL DISTRICT #229

Department/Bldg.:	Business Operations	Requested By:	Jason Gillam
Purpose: (please explain in detail why we need the items or services requested)			
Purchase of chairs for District office staff			
Fund:	Bond	Account Number:	47037730-0
Funding Year:	2025/2026	Location(s) items or services are for:	District Office
Does this use Bond Funds? (if yes, see below)		Yes	
<input type="checkbox"/> This request includes extended warranty, service or maintenance. Please complete the <u>Bond Warranty Agreement Form on page 2</u>		<input type="checkbox"/> This request includes training or consultation. Please complete <u>Bond Consultant Services Form on Page 3</u>	

Check all that apply to this Purchase:

- | | |
|--|--|
| <input type="checkbox"/> This is a New Contract | <input type="checkbox"/> This is a New Bid/RFP |
| <input type="checkbox"/> This is a Renewal Contract | <input type="checkbox"/> This is a Purchase from Bid/RFP # _____ |
| <input type="checkbox"/> This is a Curriculum purchase | <input type="checkbox"/> This Purchase requires BOE Signatures |
| <input checked="" type="checkbox"/> This can be purchased off of <u>Omnia Partners</u> Contract # <u>R240117</u> | |
| OK NH 8/27/25 | |

Begin Date: 9/1/2025	End Date: 12/31/2025
Company: HON Company	Street Address: 200 Oak Street
Contact Name: Tyler Bosley	City: 4000 Washington Street
Telephone: (816) 810-3735	State: MO
Email: tbosley@fre3dom.net	Zip Code: 64111
Cost: \$ 32,899.20	
Prior Year Cost: N/A	
Terms: (Annual, Multi-Year, One-Time): One-Time	

Month:(board meeting) September 2025 **Budget Administrator** Jason Gillam **Date** 7/15/2025



Proposal

QUOTE NUMBER	4947
DATE	08/05/2025
EXPIRATION DATE	
CUSTOMER NAME	Blue Valley Schools
SALESPERSON	House Sales
ACCOUNT MANAGER	
TERMS	NET 30
PAGE	1 of 4

CUSTOMER
Blue Valley Schools 15020 Metcalf Ave Overland Park, KS 66223
ATTN: Accounts Payable Email: acctspayable@bluevalleyk12.org

SHIP TO
Blue Valley School District Office 15020 Metcalf Ave Overland Park, KS 66223
ATTN: Nicole Hogan Phone: 913-239-4203 Email: nhogan@bluevalleyk12.org

Line	Quantity	Description	Unit Price	Extended Amount
1	1.00	CONTRACT INFO CONTRACT: C073; Estimated Ship Date 3-4 weeks from order placement.	0.00	0.00
2	95.00	H1WMM--Y0-A-H-IM-(1)-CU-10-BL-SB-T Ignition 2 Task Mid-back, ilira back OPTION: .Y0:Simple Synchro-Tilt Control OPTION: .A:Height and Width Adj. Arm OPTION: .H:Hard Caster OPTION: .IM:4-Way Black OPTION: \$(1):Grade 1 Uph OPTION: .CU:Centurion OPTION: 10:Black OPTION: .BL:Black Adjustable Lumbar OPTION: .SB:Standard Base OPTION: .T:Black	317.36	30,149.20
3	1.00	LABOR Labor to receive, deliver, and install task chairs at BVSD District Office. Assumes regular business hours, no stair carry, and no product removal.	2,750.00	2,750.00
			SUB-TOTAL :	\$32,899.20
			TOTAL :	\$32,899.20



Proposal

QUOTE NUMBER	4947
DATE	08/05/2025
EXPIRATION DATE	
CUSTOMER NAME	Blue Valley Schools
SALESPERSON	House Sales
ACCOUNT MANAGER	
TERMS	NET 30
PAGE	2 of 4

TERMS & CONDITIONS OF SALE

PAYMENT TERMS: A deposit of 50% is required with all orders and is due at the time the order is received. Buyer agrees to pay the net balance in 30 days from receipt of invoice. A 10% retainer is optional at the request of the Buyer and with written agreement by the Seller for outstanding punch list items. Retainer is due within 10 days of completion of punch list. Payment by credit card is accepted, but a convenience charge of 3% will be added to the invoice. Buyer agrees to pay a finance charge of 1-1/2% per month on the unpaid balance of each invoice for each month it is past due. This amounts to an average finance charge of 18% on all delinquent invoices. Buyer additionally agrees to pay all expenses, attorney fees and court costs which Seller incurs by reason of Buyer's default or non-payment. Acceptance of delivery constitutes acceptance of the merchandise as delivered.

TAXES: Prices may or may not include any applicable sales, use or any other tax. Any applicable taxes will be added to price at the time of invoicing and Buyer agrees to pay same. If tax is not added, payment of tax is the responsibility of the Buyer as due to the receiving State. Applicable sales tax will be included on the invoice unless a valid Sales Tax Exemption Certificate or valid Resale Certificate is provided.

FREIGHT AND TARIFFS: Prices may not include all freight or tariff charges. Additional charges that will be billed to Seller after the acceptance of this proposal will be so noted. These costs will be added to price at the time of invoicing and are the responsibility of the Buyer. Buyer agrees to pay same.

DELIVERY AND INSTALLATION: In the event that delivery and/or installation is required as a part of the proposal, the following provisions shall apply.

1. **CONDITION OF JOB SITE** – The job site shall be clean, clear, and free of debris prior to installation. A contingency fee equal to 10% of all installation costs, based on job site conditions, may be added to the final invoice. This fee will only be added after a discussion with and approval from the Buyer. Installation of any product will only occur after the jobsite has received either a Certificate of Occupancy or Temporary Certificate of Occupancy, and all other trades are off the jobsite or within the same locality.
2. **JOB SITE SERVICE** – Electric current, heat, hoisting and/or elevator service will be provided without charge to Seller. Adequate facilities for off-loading, staging, moving, and handling of merchandise shall be provided. Any move-in fees, loading dock fees, elevator reservation fees or the like will be Buyer's responsibility. Buyer also agrees that any fees or labor costs incurred by Seller as a result of move-in, loading dock, or elevator delays will be at Buyer's expense. Buyer is responsible for any mechanical, electrical, or plumbing connections to the building unless otherwise noted above. Any electrical connection from the building power to the furniture is not included in the pricing and must be performed by a licensed electrician, unless otherwise noted.
3. **ELETRICAL CODE** – Seller will specify product to meet required electric code. When Chicago or New York City electric code is required, the Seller will provide the back boxes, but hardwiring the boxes will be at the Buyer's expense.
4. **SPECIAL PACKAGING OR HANDLING** – If special packaging or handling is required that is not contained in the specification, it will be subject to an extra charge to the Buyer. Unless otherwise and previously noted, and when applicable, a completely accessible and operable elevator will be available for use by the installation crew during normal business hours as stated below. A "stair-carry" will result in additional charges and will be added to the final invoice. Buyer is responsible for coordination and receiving of product directly shipped to site, offloading and unpacking, unless otherwise noted.
5. **DELIVERY DURING NORMAL BUSINESS HOURS** – Delivery, receiving of product at the job site, installation will be made during normal working hours (Monday – Friday 8:00 AM – 4:00 PM). Overtime work performed at the Buyer's request will be billed at 1.5 times the hourly rate for evenings and Saturday and 2 times the hourly rate for Sundays. All labor services are priced as (1) single phase delivery and installation, Non-union non-prevailing wage labor, unless otherwise noted. Additional trip charges may result in added costs to the buyer.
6. **DAMAGE** – After arrival at the site, any loss or damage by weather, or trades, such as painting or plastering, by fire or other element shall be the responsibility of the Buyer, and the Buyer agrees to hold Seller harmless from loss for such reasons.
7. **DELAYS** – Seller is not responsible for delays in delivery due to conditions beyond our control, which includes manufacturer's ability to complete production and shipping. Buyer is responsible for delays if site is not ready for installation as scheduled, additional charges for double handling will be added to the final invoice for any product redirected and stored at a warehouse. Any change to an order, including but not limited to, date moves, product changes, product deletions, or ship to changes may incur additional fees once the order has been placed.

WARRANTY AND LIMITATION OF REMEDIES: The only warranties which are provided are those of the manufacturer. The Seller hereby EXPRESSLY DISCLAIMS ALL OTHER WARRANTIES INCLUDING BUT NOT LIMITED TO, THE IMPLIED WARRANTIES OF MERCHANTABILITY AND FITNESS FOR A PARTICULAR PURPOSE. Resort to the manufacturer's warranty constitutes the Buyer's exclusive



Proposal

QUOTE NUMBER	4947
DATE	08/05/2025
EXPIRATION DATE	
CUSTOMER NAME	Blue Valley Schools
SALESPERSON	House Sales
ACCOUNT MANAGER	
TERMS	NET 30
PAGE	3 of 4

remedy. In any event, no consequential or incidental damages are recoverable from the Seller.

WAREHOUSE AND STORAGE: Merchandise is ordered to meet specific installation schedules and based on current manufacturer lead times at the time this document is signed. If the Buyer delays delivery beyond the original agreed installation date, the Buyer will be billed as set forth in the billing provision below, and merchandise will be stored for future delivery. The Buyer agrees to pay all storage and restocking fees that may result from any revision, by the Buyer, to any part of an order related to this proposal.

CONCEALED DAMAGES: Buyer is held responsible for inspection of product received directly to customer site within (3) business days of delivery and/or proof of delivery. If Buyer does not provide a response in a timely manner, Buyer may incur charges related to concealed damages outside the manufacturer covered concealed damage policy. If the Buyer delays delivery beyond the original agreed installation date and the product must be stored awaiting installation, the Buyer may incur charges related to concealed damages outside the manufacturer policy.

INSURANCE: Seller agrees to furnish adequate insurance for products stored in Seller's facilities or in transit in Seller's trucks. Buyer agrees to provide adequate insurance coverage for products that are on-site at Buyer's location including work-in-process, stored materials, and finished products.

SUBSTANTIAL COMPLETION: Substantial completion occurs on the date when the work covered by this agreement is sufficiently complete so that Buyer can occupy or utilize the Project work area or designated portion thereof for it's intended use.

BILLING: All merchandise will bill immediately upon delivery unless otherwise provided herein. All direct shipments and C.O.M. charged from factory to Buyer are billed immediately upon shipment notification from the supplier. All merchandise ordered is to be delivered upon receipt. Upon receipt of the merchandise by Seller, if Buyer delays delivery beyond the original agreed installation date, for any reason, Buyer will be billed 90% of the total sales price including taxes and shipping cost. The remaining 10% of the total sales price will be billed upon delivery or installation of the merchandise. In addition, if the delivery of the merchandise is delayed for more than 30 days beyond the original agreed installation date, the Buyer will be charged a storage fee of 1 ½% per month of the total sales price including taxes and shipping cost. Should any product be missing or damaged, payment for this product may be withheld until the product has been produced or reproduced and installed. Payment for installation services is due upon completion of said services.

ACCEPTANCE: This proposal for the purchase of merchandise must be approved and submitted to the Seller within 10 days to ensure firm prices, unless otherwise agreed upon. Time is of the essence.

CANCELLATION: In the event that this proposal is approved and submitted by the Buyer to the Seller and becomes an order, it is understood and agreed that it cannot be cancelled or changed except by written mutual consent. All orders are non-returnable and non-refundable, unless otherwise noted.

ANY MERCHANDISE ORDERED AS SPECIAL: For special installations, products upholstered with specifically chosen colors of fabrics and/or metal colors or specific wood finishes ARE NOT RETURNABLE.

DESIGN: All design coordinated layouts, equipment suggestions and colors are the exclusive property of Seller and use of them by other parties is prohibited.

SECURITY INTEREST: Buyer hereby grants to Seller a security interest in all items or goods furnished pursuant to this contract and in the proceeds thereof (the "Collateral"), to secure the payment of all charges hereunder including, but not limited to, the purchase price for all such items or goods, costs of storage, and costs of collection including without limitation reasonable attorneys' fees and expenses. In the event of any default, Seller may enter upon the premises where the Collateral is located and immediately repossess same, and dispose of same by private or public sales after five (5) calendar days written notice to Buyer, and the proceeds of such disposition shall be first applied to any attorneys' fees or expenses of collection incurred by Seller and the balance applied to any amounts then owed by Buyer to Seller by reason of goods or services work, labor or material furnished pursuant to this document. By signing below, Customer acknowledges that this contract serves as a security agreement within the meaning of the Uniform Commercial Code (UCC), and Customer agrees that Company may file such UCC financing statements as are appropriate to perfect Company's security interest in the Equipment. In addition to all other rights that it may possess, Seller shall have the right, at any time for credit reasons, or because of any Buyer default or defaults, to withhold shipments, in whole or in part, and to recall goods in transit, retake same and repossess all goods which may be stored with Seller for Buyer's account, without the necessity of taking any other proceedings, and Buyer consents that all the goods so recalled, retaken, or repossessed shall become the absolute property of Seller, as to such default. In the event Buyer is in default of any of its obligations hereunder or of any other obligations to Seller, Seller may, in addition to any other rights or remedies provided for herein or available to Seller at law or in equity: (i) withhold performance of any obligation of Seller hereunder or any other obligation of Seller to Buyer, including delivery and/or installation of any other goods, and (ii) set-off against any amount owed Buyer an amount equal to the damages incurred by Seller arising out of Buyer's default hereunder or under any other obligation of Buyer to Seller.

MEDIATION AND ARBITRATION: All disputes between the Parties arising out of this Agreement shall be resolved by submission to Mediation on



Proposal

QUOTE NUMBER	4947
DATE	08/05/2025
EXPIRATION DATE	
CUSTOMER NAME	Blue Valley Schools
SALESPERSON	House Sales
ACCOUNT MANAGER	
TERMS	NET 30
PAGE	4 of 4

the following terms: The parties shall attempt in good faith to mediate such dispute and use their best efforts to reach agreement on the matters in dispute. After a written demand for non-binding mediation which shall specify in detail the facts of the dispute, and within ten (10) days from the date of delivery of the demand, the matter shall be referred to a mediator selected by mutual agreement. The Mediator shall hear the matter and provide an informal opinion and advice, none of which shall be binding upon the parties, but is expected by the parties to help resolve the dispute. Said informal opinion and advice shall be submitted to the parties within forty (40) days following written demand for Mediation. The Mediator's fee shall be shared equally by the parties. Should any dispute not be resolved by Mediation, the dispute shall be submitted to arbitration in Kansas City, Missouri, pursuant to the rules of the American Arbitration Association.

NO OTHER AGREEMENTS: The parties covenant by their signature hereto and specifically represent that they have read and reviewed this document in its totality and that it sets forth the entire agreement the parties regarding the transaction set forth herein. Specifically, the parties agree there are no other terms, conditions, or agreements, express or implied, other than those set forth herein except those set forth in the specifications, delivery, and installation schedules of the Seller. To the extent that the Buyer has submitted any terms, conditions, or agreements which differ from those set forth in this document, those terms, conditions, and agreements are hereby objected to and rejected by the Seller. The terms and conditions of this agreement cannot be varied except upon the written approval of both Buyer and Seller.

Thank you for giving us the opportunity to help create your new workplace. We look forward to a longstanding, successful partnership. To provide you with the highest quality service, we need the following:

- Signed Proposal with 50% Deposit (if applicable)
- 25% Progress Payment (applicable to most projects) upon shipment of merchandise from suppliers.
- Balance payment within 30 days of final invoicing

I agree to the terms and conditions above.

Buyer Company Name: _____

Authorized Signature: _____

Name: _____

Title: _____

Date: _____



PURCHASING UNIVERSAL REQUEST

BLUE VALLEY SCHOOL DISTRICT #229

Department/Bldg.:	Facilities	Requested By:	Andy Spruill
Purpose: (please explain in detail why we need the items or services requested)			
Handicap ramp for stages used at all facilities.			
Fund:	Capital Outlay	Account Number:	016001810-7014
Funding Year:	2025/2026	Location(s) items or services are for:	District wide
Does this use Bond Funds? (if yes, see below)		No	
<input type="checkbox"/> This request includes extended warranty, service or maintenance. Please complete the <u>Bond Warranty Agreement Form on page 2</u>		<input type="checkbox"/> This request includes training or consultation. Please complete <u>Bond Consultant Services Form on Page 3</u>	

Check all that apply to this Purchase:

- | | |
|--|--|
| <input type="checkbox"/> This is a New Contract | <input type="checkbox"/> This is a New Bid/RFP |
| <input type="checkbox"/> This is a Renewal Contract | <input type="checkbox"/> This is a Purchase from Bid/RFP # _____ |
| <input type="checkbox"/> This is a Curriculum purchase | <input type="checkbox"/> This Purchase requires BOE Signatures |
| <input checked="" type="checkbox"/> This can be purchased off of <u>Omnia Partners</u> Contract # <u>R240120</u> | |
| OK NH 08/19/25 | |

Begin Date: 8/19/2025	End Date: 12/31/2025
Company: Wenger Corporation	Street Address: 555 Park Drive
Contact Name: Lisa Lewis	City: Owatonna
Telephone: (507) 455-4100	State: MN
Email: lisa.lewis@wengercorp.com	Zip Code: 55060
Cost: \$ 21,799.33	
Prior Year Cost:	
Terms: (Annual, Multi-Year, One-Time): One-Time	

Month:(board meeting) September 2025 **Budget Administrator** Jake Slabodnik **Date** 8/19/2025

Wenger Corporation
 555 Park Drive
 Owatonna, MN 55060-4940
 United States



Phone: 507-455-4100
 Fax: 507-455-4258

Quote Number: 3357018

QUOTE

Date: 04/23/2025
 Page: 1 of 2
 Cust #: 00082057

StageTek 24" ADA Ramp w/ Right Hand Landing

<p>Quote To: William Waisner Blue Valley Unif Sch Dist 229 PO Box 23901 Overland Park KS 66283-0901 United States</p> <p>Phone: (913) 239-4069 Fax: E-Mail: wwaisner@bluevalleyk12.org</p>	<p>Date: 4/23/2025 Expires: 5/23/2025 Reference: Terms: Net 30 Days Created By: Erynne Reyes</p> <p>Salesperson: Lisa Lewis Phone: E-Mail: Lisa.Lewis@wengercorp.com</p>
---	--

Quote Comments:

 * Wenger is an approved vendor for Region 4 ESC/OMNIA Partners, Public Sector. All items on this quotation are available through Contract #R240120. This contract is in effect through 12/31/2027. Payment shall be made after satisfactory performance, in accordance with all the provisions thereof, and upon receipt of a properly completed invoice. All transactions, purchase orders, etc. will occur directly between the Supplier, authorized distributor/dealer, general contractor, as agreed to by each Participating Public Agency. Per OMNIA participation requirements, all purchase orders issued to Wenger Corporation must reference OMNIA contract #R240120.

Customer to check and verify all items before ordering.

Freight quoted is for a one-time shipment. As a result, once orders placed, delivery dates may change. Customer-requested split shipments will result in an additional freight charge.

Wenger Corporation expressly incorporates by reference all of the terms and conditions as specified at: (www.wengercorp.com/terms-and-conditions.php) and makes them part of this quotation.

Current estimated lead-time is 6-7 week(s) plus transit, subject to change.

Tariffs, Taxes, Duties, Fees and Permits Imposed: With respect to any product purchase hereunder, if any federal, state or local Tariff, Tax, Duty, Fee or Permit is imposed by Applicable Law on the Seller in connection with any such purchase, then the Buyer shall be required to pay to Seller such additional costs.

Line	PartNum/Description	Qty	Net Price	Ext. Price
1.00	282A015 RAMP,24"ELEV,RH LNDG	1 EA	\$18,198.00	\$18,198.00
	**Optional Mid-Rails are Recommended			
2.00	113K001 Staging Universal Deck & Rail Cart	3 EA	\$929.00	\$2,787.00

Wenger Corporation
 555 Park Drive
 Owatonna, MN 55060-4940
 United States



C O R P O R A T I O N

Phone: 507-455-4100
 Fax: 507-455-4258

Quote Number: 3357018

QUOTE

Date: 04/23/2025
 Page: 2 of 2
 Cust #: 00082057

StageTek 24" ADA Ramp w/ Right Hand Landing

3.00	281A600 LEG STORAGE CLIP,STAGETEK INDOOR,4 PK	6 EA	\$15.00	\$90.00
4.00	Freight Freight Services	1 EA	\$724.33	\$724.33

TAILGATE DELIVERY with STAGING:

Freight reflected in this quotation is for common carrier shipment with tailgate delivery. Tailgate delivery will require your staff to unload the truck, move the product into the building and complete any assembly or installation.

**LIFTGATE DELIVERY NOT AVAILABLE FOR STAGING, See unloading recommendations.
 DO YOU REQUIRE INSIDE DELIVERY OR INSTALLATION SERVICES?**

If you do not have a loading dock or staff available to unload the products from the common carrier trailer, then contact your Wenger sales representative to discuss these delivery methods and to find out the additional charges.

If you are a tax-exempt organization and quote includes tax, please send a copy of your tax-exempt certificate and we will remove the sales tax. Thank you.

Lines Total \$21,799.33
 Total Taxes \$0.00

Quote Total \$21,799.33



MUSIC EDUCATION AND PERFORMING ARTS

Owatonna Office: Phone 800.4WENGER (493-6437) Worldwide +1.507.455.4100 | Parts & Service 800.887.7145 | wengercorp.com | 555 Park Drive, PO Box 448 | Owatonna | MN 55060-0448

Syracuse Office: Phone 800.836.1885 Worldwide +1.315.451.3440 | jrclancy.com | 7041 Interstate Island Road | Syracuse | NY 13209-9713

ATHLETICS Phone 800.493.6437 | email gearboss@wengercorp.com | gearboss.com | 555 Park Drive, PO Box 448 | Owatonna | MN 55060-0448



PURCHASING UNIVERSAL REQUEST

BLUE VALLEY SCHOOL DISTRICT #229

Department/Bldg.:	Business Office	Requested By:	Jason Gilliam
Purpose: (please explain in detail why we need the items or services requested)			
This purchase is to move EMS software from a local server supported license to a cloud license to allow for access to EMS across all computer platforms across the district. This is a three-year subscription paid upfront.			
Fund:	General Fund	Account Number:	23087
Funding Year:	2025/2026	Location(s) items or services are for:	District Wide
Does this use Bond Funds? (if yes, see below)		No	
<input type="checkbox"/> This request includes extended warranty, service or maintenance. Please complete the <u>Bond Warranty Agreement Form on page 2</u>		<input type="checkbox"/> This request includes training or consultation. Please complete <u>Bond Consultant Services Form on Page 3</u>	

Check all that apply to this Purchase:

- This is a New Contract
- This is a Renewal Contract
- This is a Curriculum purchase
- This can be purchased off of _____ Contract # _____
- This is a New Bid/RFP
- This is a Purchase from Bid/RFP # _____
- This Purchase requires BOE Signatures

Begin Date: 11/1/2025	End Date: 6/30/2028
Company: Accruent LLC	Street Address: 11501 Domain Dr Suite 160
Contact Name: Billie Hawkins	City: Austin
Telephone: (513) 861-0726	State: TX
Email: billie.hawkins@accruent.com	Zip Code: 78758
Cost: \$ 100,253.50 Estimated	
Prior Year Cost: N/A	
Terms: (Annual, Multi-Year, One-Time): Multi-Year	

Month:(board meeting) September 2025 **Budget Administrator** _____ **Date** 8/27/2025



Client Information

Client Name:	Blue Valley School District	Client Contact Name:	Jim Ryan
Bill To:	Accounts Payable PO Box 23901 Overland Park, KS 66283 United States	Client Contact Email:	jpryan@bluevalleyk12.org
Ship To:	Accounts Payable 14950 Metcalf Avenue Overland Park, KS 66283 United States	Client Contact Phone:	(913) 239-4258
Billing Email:	kgillam@bluevalleyk12.org	Account Number:	A-00136577

Quote Information

Quote #:	Q-307055-5	Quote Expiration:	9/12/2025
Invoice Frequency:	Annual	PO Number:	
Project Name:	EMS Cloud Migration		

Product Information and Fees

Product	Quantity	Period 11/1/2025 - 10/31/2026	Period 11/1/2026 - 10/31/2027	Period 11/1/2027 - 10/31/2028	Total Fees
EMS Enterprise Events Hosted - Package Fee	1 Subscription(s)	19,500.00	19,500.00	20,475.00	USD 59,475.00
Room, Workspace & Event Scheduling Platform Includes: Desktop Client, WebApp, HR Toolkit, Integrated Authentication, Exchange Integration, Hosting Services & Accruent Academy					
EMS Advanced Users	9,999 User(s)	4,000.00	4,000.00	4,200.00	USD 12,200.00
EMS End Users	9,999 User(s)	3,750.00	3,750.00	3,937.50	USD 11,437.50
EMS Room Sign Subscription	20	2,520.00	2,520.00	2,646.00	USD 7,686.00

Product	Quantity	Period 11/1/2025 - 10/31/2026	Period 11/1/2026 - 10/31/2027	Period 11/1/2027 - 10/31/2028	Total Fees
EMS Calendaring Integration - MS 365 - Outlook	1 License(s)	3,100.00	3,100.00	3,255.00	USD 9,455.00
Includes access to EMS for Outlook					
Total		USD 32,870.00	USD 32,870.00	USD 34,513.50	USD 100,253.50

Services Fees

Fixed Fee Services

Service Description	Net Total Price
EMS Cloud Migration	USD 6,800.00
EMS - HR Toolkit Migration	USD 2,900.00
TOTAL:	USD 9,700.00

Additional Terms

- 1 Accruent shall grant a license to access the SaaS Services for the non-cancelable period listed above ("Committed SaaS Term"). The maximum annual increase to fees during the Committed SaaS Term shall not exceed percent. Thereafter, the SaaS Services shall automatically renew at the then current fees.
- 2 If the invoice period reflects a term of less than 12 months, the recurring fees are prorated and will renew as permitted under the Agreement at the annualized rate.
- 3 Unless Client has a separate negotiated master services agreement or other binding agreement in place with Accruent, by signing below, Client agrees that this Order Document is subject to the end user license agreement set forth at: https://www.accruent.com/end_user_license_agreement.
- 4 Client shall continue to pay for its Maintenance and Support and/or Licensing Fees for its On-Premise License per until the Start Date of this Order Document. Upon the Start Date, all Term On-Premise Licenses and the Maintenance and Support for all On-Premise Licenses shall be terminated.
- 5 The Order Document has an effective date of _____ ("Start Date").
- 6 Unless otherwise specified herein, Professional Services are governed by the terms set forth at: http://www.accruent.com/professional_services_terms.
- 7 Fixed Fee Services and Time & Materials Services ordered hereunder will be available to Client for 90 days from the Start Date. After such date, any unused portion of the Services defined will be forfeited unless otherwise agreed upon by both parties through Change Control process.
- 8 If Client has ordered educational services, the Accruent Academy Terms shall apply, available at: http://www.accruent.com/academy_terms.

Acknowledged and Agreed by the Duly Authorized Representatives of the Parties

Client: Blue Valley School District	Accruent, LLC
Signature:	Signature:
Print Name:	Print Name:
Title:	Title:
Date:	Date:
Accruent requires a PO, send PO to your Accruent representative or customerpo@accruent.com. To avoid invoicing issues or a potential disruption in your services, please include the Quote # above in your PO.	
If you are tax exempt, provide exemption certification to your Accruent representative or salestax@accruent.com.	

Exhibit 1 – Statement of Work

PROJECT OVERVIEW	
Product:	EMS
Offering Delivered:	Migration - Cloud
Summary:	Accruent will provide professional services to migrate client’s existing on-premise EMS production database to the Accruent cloud.
Duration:	Estimated project duration is up to 5 weeks from project start. Accruent will assign a project when client has indicated readiness by confirming the pre-migration steps outlined below are complete.
Delivery:	Remote engagement only.

CLOUD MIGRATION PLAN AND TIMELINE		
Timeline	Task	Roles/Responsibilities
Migration Preparation		
Pre-Migration	Prepare for Migration	<p>Client reviews system prerequisites for end user components; meets with stakeholders to align on project schedule and responsibilities.</p> <p>https://success.emssoftware.com/Content/System%20Requirements/SystemRequirements_Home.htm?tocpath=System%20Requirements%7C_0</p> <p>If in scope, Client reviews HR Toolkit specifications and prepares modifications to user provisioning export.</p>
Technical Session & Migration in Test		
Week 1	<p>Project Overview & Technical Review call</p> <p>Test Migration Executed</p> <p>Environment Review Session</p>	<p>Client provides description of current EMS environment, including modules in-use in production and description of intended use.</p> <p>Project Manager and Client collaborate on dates for migration activities.</p> <p>Client provides current backups of their on-premise production databases for upgrade and migration into Sandbox EMS Cloud.</p> <p>Accruent Technical Engineer completes migration of each module identified by Client as in production-use in current environment and licensed for use. (New modules are not configured or tested as part of the migration package).</p>
Integration Review and Configuration		
Week 2	Integration(s) Working Session	Project Team reviews and configures integration points in Test: User Provisioning (HR Toolkit), Authentication, and Exchange Integration as applicable.
Workflow Testing		
Weeks 3-4	Client completes UAT/Workflow Testing	Client accesses EMS Test system and completes testing of existing workflows. Client documents any issues found during testing that did not already exist and reports those issues to the Accruent team.

Production Migration		
Week 5	Production Migration Executed Production Integration Configuration Go-Live Stabilization Calls I and II	Client provides current backups of their databases for upgrade and migration into Production EMS Cloud. Accruent Technical Engineer completes migration of each module identified by Client as in production-use in current environment and licensed for use. (New modules are not configured or tested as part of the migration package). Project Team configures applicable integration points in Production

ASSUMPTIONS & RESPONSIBILITIES

1. The Client project team should consist of the following roles. Technical resources and Business Owners with knowledge of the EMS application are critical for an effective engagement.

Client Implementation Team

Role	Responsibilities
Project Manager	Will work hand in hand with EMS Project Manager, assist in creation of project plan, coordinate project resources, and assist to drive project timeline.
IT	Will provide database backups. Will prepare for deployment of end user applications: EMS Desktop Client application and EMS for Outlook add-in. Will provide expertise on authentication methods, Exchange integration information, and mail administration as applicable. If currently using HR Toolkit on-premise, will update user provisioning data to current cloud specifications.
Business Owners	Will participate in UAT to ensure current workflows are intact following the migration/upgrade.

2. Accruent EMS project team will consist of the following resources as applicable to the scope of the engagement:

Accruent Implementation Team

Role	Responsibilities
Accruent Project Sponsor	Is accountable for project success; determines project success criteria and monitors project performance. Role fulfilled by Professional Services Manager.
Accruent Project Manager	Works hand in hand with Client Project Manager to draft and maintains Project Plan; drives timeline and ensures scope completion; keeps Client up to date on project progress, risks, and issues. Closes out project and transitions to Customer Support.
Accruent Technical Engineer	Provides technical guidance; Upgrades client database and migrates to Cloud Sandbox and Production environments. Works with client on any integrations including Exchange, Authentication, and Account Provisioning (HR Toolkit). Advises on application deployment.

3. Client has reviewed system prerequisites for installation of EMS end user components in scope (example: EMS Desktop Client and EMS for Outlook) and reviewed configuration specifications for integration points as applicable to scope (example: HR Toolkit, Exchange, Teams, Zoom, Webex). Client has technical resources familiar with SQL, IIS, and Exchange in conjunction with scope of implementation.

https://success.emssoftware.com/Content/System%20Requirements/SystemRequirements_Home.htm?tocpath=System%20Requirements%7C_____0

4. The Migration will be performed for specific EMS modules and services running in Production. If additional modules are licensed or included in the Cloud package, they will be provisioned, but not configured or tested unless specifically outlined as additional scope.

5. Accruent Cloud licensing includes only 1 EMS Data Database. If client has more than one data database, client must procure additional licensing or plan to merge the databases into one.
6. Accruent will provide an SFTP link for the Client to upload their database for test/production migrations. Client will provide database backups on agreed upon date and time to facilitate migration activities. Unless otherwise specified, this project assumes a single EMS data database and single EMS Master database.
7. Accruent will provide an SFTP link for the Client to upload their HR Toolkit data file(s) on an ongoing basis once EMS is migrated to the cloud. The upload cadence will be at the Client's discretion; however, a nightly upload is recommended. The data file(s) must be in a flat file format.
8. EMS Campus Clients are required to host the EMS Campus Web Service on their own servers. Accruent will work with client team to connect the cloud instance of EMS to the on-premise Campus Web Service. The Campus Web Service will be maintained by the Client.
9. Client will fully test applicable workflows currently executed in EMS. Client will identify user testing participants and collect test responses.

AFTER HOURS ENGAGEMENT

Accruent and Client Project Managers will collaborate and agree to specified dates and times for services to be delivered during standard business hours Monday – Thursday (Friday, non-production only) to maximize availability of Professional Services and non-emergency team members. Any services delivered outside of those hours will be subject to availability and invoiced an after-hours fee of \$15,000 account for the additional overtime staffing and resourcing required to provide the after-hours activities. If applicable, this premium will be documented and executed via change order.



PURCHASING UNIVERSAL REQUEST

BLUE VALLEY SCHOOL DISTRICT #229

Department/Bldg.:	SPED	Requested By:	Dr. Mark Schmidt
Purpose: (please explain in detail why we need the items or services requested)			
Student (AT) will attend private school at Behavioral Health Allies Academy based on an IEP decision.			
Fund:	Special Education	Account Number:	26090
Funding Year:	2025/2026	Location(s) items or services are for:	BHA Academy
Does this use Bond Funds? (if yes, see below)		No	
<input type="checkbox"/> This request includes extended warranty, service or maintenance. Please complete the <u>Bond Warranty Agreement Form on page 2</u>		<input type="checkbox"/> This request includes training or consultation. Please complete <u>Bond Consultant Services Form on Page 3</u>	

Check all that apply to this Purchase:

- | | |
|--|--|
| <input type="checkbox"/> This is a New Contract | <input type="checkbox"/> This is a New Bid/RFP |
| <input type="checkbox"/> This is a Renewal Contract | <input type="checkbox"/> This is a Purchase from Bid/RFP # _____ |
| <input type="checkbox"/> This is a Curriculum purchase | <input type="checkbox"/> This Purchase requires BOE Signatures |
| <input type="checkbox"/> This can be purchased off of _____ Contract # _____ | |

Begin Date: 7/1/2025	End Date: 6/30/2026
Company: Behavioral Health Allies	Street Address: 10330 Hickman Mills Dr
Contact Name: Ian Hanover	City: Kansas City
Telephone: (816) 994-2600	State: MO
Email: ian.hanover@behavioralhealth.org	Zip Code: 64137
Cost: \$ 97,000.00 Estimated	
Prior Year Cost: \$ 82,395.25	
Terms: (Annual, Multi-Year, One-Time): Annual	

Month:(board meeting) September 2025 **Budget Administrator** Dr. Mark Schmidt **Date** 8/21/2025



PURCHASING UNIVERSAL REQUEST

BLUE VALLEY SCHOOL DISTRICT #229

Department/Bldg.:	SPED	Requested By:	Dr. Mark Schmidt
Purpose: (please explain in detail why we need the items or services requested)			
Student (AT) will be transported to Behavioral Health Allies Academy from their home, and student (AM) will be transported from Behavioral Health Allies to KVC Academy.			
Fund:	Special Education	Account Number:	26133
Funding Year:	2025/2026	Location(s) items or services are for:	BHA Academy
Does this use Bond Funds? (if yes, see below)		No	
<input type="checkbox"/> This request includes extended warranty, service or maintenance. Please complete the <u>Bond Warranty Agreement Form on page 2</u>		<input type="checkbox"/> This request includes training or consultation. Please complete <u>Bond Consultant Services Form on Page 3</u>	

Check all that apply to this Purchase:

- | | |
|--|--|
| <input type="checkbox"/> This is a New Contract | <input type="checkbox"/> This is a New Bid/RFP |
| <input checked="" type="checkbox"/> This is a Renewal Contract | <input type="checkbox"/> This is a Purchase from Bid/RFP # _____ |
| <input type="checkbox"/> This is a Curriculum purchase | <input type="checkbox"/> This Purchase requires BOE Signatures |
| <input type="checkbox"/> This can be purchased off of _____ Contract # _____ | |

Begin Date: 9/1/2025	End Date: 8/31/2026
Company: Behavioral Health Allies	Street Address: 10330 Hickman Mills Drive
Contact Name: Ian Hanover	City: Kansas City
Telephone: (816) 994-2600	State: MO
Email: ian.hanover@behavioralhealth.org	Zip Code: 64137
Cost: \$ 207,120.00 Estimated	
Prior Year Cost: N/A	
Terms: (Annual, Multi-Year, One-Time): Annual	

Month:(board meeting) September 2025 **Budget Administrator** Dr. Mark Schmidt **Date** 8/22/2025



PURCHASING UNIVERSAL REQUEST

BLUE VALLEY SCHOOL DISTRICT #229

Department/Bldg.:	SPED	Requested By:	Dr. Mark Schmidt
Purpose: (please explain in detail why we need the items or services requested)			
Student (BF) will attend Brighthouse Academy for the 25-26 school year. This is an IEP decision.			
Fund:	Special Education ▼	Account Number:	26090
Funding Year:	2025/2026 ▼	Location(s) items or services are for:	Brighthouse Academy
Does this use Bond Funds? (if yes, see below)			
<input type="checkbox"/> This request includes extended warranty, service or maintenance. Please complete the <u>Bond Warranty Agreement Form on page 2</u>		<input type="checkbox"/> This request includes training or consultation. Please complete <u>Bond Consultant Services Form on Page 3</u>	

Check all that apply to this Purchase:

- | | |
|--|--|
| <input checked="" type="checkbox"/> This is a New Contract | <input type="checkbox"/> This is a New Bid/RFP |
| <input type="checkbox"/> This is a Renewal Contract | <input type="checkbox"/> This is a Purchase from Bid/RFP # _____ |
| <input type="checkbox"/> This is a Curriculum purchase | <input type="checkbox"/> This Purchase requires BOE Signatures |
| <input type="checkbox"/> This can be purchased off of _____ Contract # _____ | |

Begin Date: 8/18/2025	End Date: 8/18/2026
Company: Brighthouse Academy LLC	Street Address: 4601 E Douglas Ave, Ste 150
Contact Name: Grant Solomon	City: Wichita
Telephone:	State: KS
Email: grantsolomon@thebighthouseacademy.com	Zip Code: 67218
Cost: \$ 99,000.00 Estimated ▼	
Prior Year Cost: n/a	
Terms: (Annual, Multi-Year, One-Time): Annual	

Month:(board meeting) September 2025 **Budget Administrator** Dr. Mark Schmidt **Date** 9/3/2025

The Brighthouse Academy
SCHOOL CONTRACT SERVICE AGREEMENT

This contract made effective as of the 08/18/2025 by and between The Brighthouse Academy LLC (herein after termed “Provider”) with its practice location at 10001 W 88th St, Overland Park, KS 66212, and Blue Valley School District (hereinafter termed the “Client”) with their locations within Johnson County, KS, and

WITNESSETH

WHEREAS, the Client desires to provide services (as hereinafter described) to benefit students and,

WHEREAS, the Provider has appropriate programs/services, capacity, and competence to provide the services hereinafter described for the Client;

NOW, THEREFORE, in consideration of the premises and the mutual agreements contained herein, the parties hereby agree as follows:

1. **Scope of Services.** The Provider may provide the following services:

- Provide special education and related services as outlined in student(s) IEP, attend IEP meetings, when necessary, assist with programming including data monitoring, assist with the creation and implementation of behavior programs and plans, communicate with the Client designated special education administrator and parent(s) as appropriate.
- General education curriculum and instruction shall be delivered through a virtual education platform, with oversight and assistance from the Provider’s staff. Upon request, “Client” will provide access to a suitable virtual platform, and the monthly charge will be decreased by the actual cost “Client” expends on one virtual seat.
- Provide functional behavior assessments for integration into student IEP (if applicable).
- Provide individualized behavior plans outlining goals and objectives targeting maladaptive behavior and skill deficits.
- Provide transitional plans and programming support within the district school setting.
- Provide individualized and student-specific trainings for District Staff throughout the transition period.
- All services shall be performed within the general scope of community standards, meeting all applicable federal, state, and local regulations and standards in a professional, ethical, and competent manner and as prescribed by such professional associations as are applicable to the Provider’s services. The Provider shall provide services to students without regard to race, creed, color, religion, age, sex, disability, marital status, or sexual or affectional preference. The Provider represents that it is qualified to and capable of performing the

services listed herein.

- The Provider represents and warrants that it operates, and it agrees that it will continue to operate, in compliance with all applicable federal, state, and local laws and regulations, including but not limited to, the Family Educational Rights and Privacy Act (“FERPA”), the Individuals with Disabilities Education Act (“IDEA”), Section 504 Rehabilitation Act, all the applicable civil rights laws, and a Federal Work Authorization Program. The Provider further agrees that it will abide by the terms of District policies and procedures. The Provider further acknowledges receipt of the District’s policies and procedures and acknowledges that any violation of District policies and procedures is cause for immediate termination of this contract and any services related thereto.
- Services will be performed in accordance with any IEPs and other qualification standards. The District shall provide The Provider with each student’s most recent IEP upon initiation of this Contract. The Provider shall be responsible for maintaining adequate communication with the District as required for evaluation of the student(s).
- The Provider’s employees shall be fingerprinted and background checked in accordance with the background checks required pursuant to Kansas Teacher Licensure Procedures. Passing said background check is a condition precedent to the Provider’s employees’ provision of services under this Contract.

2. Confidentiality. On and after the date of this agreement, Provider shall keep confidential all information relating to Clients and any student referred to Provider by Client, including, but not limited to, any medical, clinical, and academic information, in whatever form. The Provider shall be responsible for ensuring that caregivers have consented to the service, delivery, and sharing of confidential student information. Client shall keep confidential all information relating to Provider’s work for Client or its students, including, but not limited to, any clinical and academic training or services in whatever form. Client agrees that the clinical and academic services provided by Provider are trade secrets of Provider as that term is defined in the Kansas Uniform Trade Secrets Act.

3. Payment. Payments for services will be at the rate of \$8,250.00 per full-time student per month and \$4,500.00 per half-day student per month, for 12 months. These rates apply from the Effective Date through August 18, 2026. Invoices are due within 60 days of receipt. Any partial month will be billed pro rata. Monthly payment for contracted services will be sent to Provider at 10001 W 88th St, Overland Park, KS 66212 or to the provided banking information. If Provider files suit to collect any payment due hereunder, then in addition to the amount owed under this Agreement, Provider will be entitled as additional damages to collect its reasonable attorney fees incurred enforcing this Agreement.

4. Term and Termination. The term of this contract shall run from the effective date of the contract as stated above through August 18, 2026. This contract will automatically renew for successive one-year terms with a 3% increase in the per student fees unless a party terminates it

under this provision or negotiates a different rate change. Either party may terminate the agreement for cause immediately. Either party shall have the right to terminate this contract at any time, with or without cause, upon 30 days' prior written notice to the other party.

5. **Independent Contractor.** The parties acknowledge that each party hereto is independent of the other and shall not be construed as an agent or representative of the other and shall have no liability for the acts or omissions of the other party. The Provider is acting as an independent contractor and is retained by the Client, solely for the provision of the personal and professional services described herein. Neither party, nor any of its employees, agents, or subcontractors, shall be deemed to be employees or agents of the other party. Therefore, neither party nor any of its employees, agents, or subcontractors shall be entitled to unemployment compensation, workers' compensation, or employee benefits of the other party under this contract, nor shall either party be responsible for income tax or other withholding as to the other party, its employees, or agents by virtue hereof.

6. **Insurance.** The Provider agrees to obtain and keep in force professional liability insurance in a minimum amount of one million dollars (\$1,000,000) per occurrence and three million dollars (\$3,000,000) aggregate and to furnish proof of such insurance to the Client when requested.

7. **Ownership of Materials, etc.** All written or oral materials, documents, pamphlets, handouts, forms, and other information provided by either party shall be the sole and exclusive property of the party providing the item, whether copyrighted or not. Items shall not be used or reproduced without the prior written approval of the party with whom they originated. No tape-recording or videotaping shall be done without the consent of both parties.

8. **Non-Solicitation.** During the term and for 12 months following termination, the District shall not directly hire or solicit for employment any Provider employee who provided services under this Agreement without Provider's written consent.

9. **Integration and Amendment.** This contract constitutes the entire agreement between the parties and contains all the agreements between the parties with respect to the subject matter hereof, except as otherwise indicated herein. This contract supersedes all prior contracts, either oral or written, between the parties with respect to the subject matter of this contract. No amendment or variation of this contract shall be valid unless it is written and signed by all parties.

IN WITNESS WHEREOF, the parties have executed the above-written contract on the date and

year listed below, but effective as of the date first written above.

The Brighthouse Academy, LLC

By: Rebecca Chapin

Date:

Blue Valley School District

By:

Blue Valley School District Representative

Date:



PURCHASING UNIVERSAL REQUEST

BLUE VALLEY SCHOOL DISTRICT #229

Department/Bldg.:	Facilities and Operations	Requested By:	Jake Slobodnik
Purpose: (please explain in detail why we need the items or services requested)			
<p><i>TEMPORARY EASEMENT AGREEMENT- Construction easement for future improvements</i></p> <p><i>This agreement is between Blue Valley School District and the City of Overland Park to dedicate a temporary construction easement to the City. This easement is required for the new middle school project.</i></p>			
Fund:	NA	Account Number:	NA
Funding Year:	2025/2026	Location(s) items or services are for:	175th Street, Overland Park
Does this use Bond Funds? (if yes, see below)		No	
<input type="checkbox"/> This request includes extended warranty, service or maintenance. Please complete the <u>Bond Warranty Agreement Form on page 2</u>		<input type="checkbox"/> This request includes training or consultation. Please complete <u>Bond Consultant Services Form on Page 3</u>	

Check all that apply to this Purchase:

- | | |
|--|--|
| <input checked="" type="checkbox"/> This is a New Contract | <input type="checkbox"/> This is a New Bid/RFP |
| <input type="checkbox"/> This is a Renewal Contract | <input type="checkbox"/> This is a Purchase from Bid/RFP # _____ |
| <input type="checkbox"/> This is a Curriculum purchase | <input type="checkbox"/> This Purchase requires BOE Signatures |
| <input type="checkbox"/> This can be purchased off of _____ Contract # _____ | |

Begin Date: 8/29/2025	End Date:
Company: City of Overland Park	Street Address: 8500 Santa Fe Drive
Contact Name: Leslie Karr	City: Overland Park
Telephone: (913) 895-6196	State: KS
Email: leslie.karr@opkansas.org	Zip Code: 66212
Cost:	\$ 0.00
Prior Year Cost:	
Terms: (Annual, Multi-Year, One-Time):	

Month:(board meeting) September 2025 **Budget Administrator** Jake Slobodnik **Date** _____

DO NOT WRITE, TYPE OR STAMP ANYTHING ABOVE THIS LINE OR IN THE MARGINS.
REMOVE THIS BOX PRIOR TO PRINTING.

Project No.
Tract No.

TEMPORARY CONSTRUCTION EASEMENT (LONG TERM)

KNOW ALL PERSONS BY THESE PRESENTS, that _____,
hereinafter the Grantor, for the sum of ten dollars (\$10.00) and other valuable considerations, receipt and
sufficiency of which is hereby acknowledged, does grant to the **CITY OF OVERLAND PARK**, a municipal
corporation in the County of Johnson, State of Kansas, hereinafter the **Grantee**, its successors and
assigns, a Temporary Construction Easement over, under and through the following described real
estate, to wit:

SEE ATTACHMENT 'A'

The above described easement is to be used for the purpose of constructing, grading, improving,
reconstructing and inspecting 175th Street to thoroughfare standards (the
"Improvement"). This Temporary Construction Easement includes the right of ingress and egress over
and through the above-described real estate. Grading within the temporary construction may result in a
grade change.

Grantor, its successors and assigns, hereby waive and release **Grantee** from any and all claims for
damages or compensation either now or in the future arising by reason of the use of said real estate for
the purpose herein described. The **Grantee**, its contractors or assigns shall not be held liable for damage
to or removal of landscaping, fencing, median islands, entrance monuments and appurtenances thereto
which damage or removal is caused or necessitated by the Improvement. The **Grantee**, its contractors or
assigns shall not be responsible for the replacement or reconstruction of these amenities should they be
damaged or destroyed by **Grantee** or its contractors or assigns in the process of constructing the
Improvement.

This Temporary Construction Easement shall commence upon written notification by the **Grantee** of the
commencement of construction of the Improvement and shall expire twenty-four (24) months after the
completion and acceptance of construction of the Improvement.

This Temporary Construction Easement shall be binding upon the heirs, executors, administrators,
successors and assigns of Grantor and shall be recorded with the Johnson County Department of
Records and Tax Administration.

TO THESE COVENANTS, the Grantor does hereby consent and agree.

Rev. Oct. 2016

DO NOT WRITE, TYPE OR STAMP ANYTHING BELOW THIS LINE.
REMOVE THIS BOX PRIOR TO PRINTING.

EXHIBIT "A"
(Page 1 of 2)

Project No.: 023-01202
Blue Valley Middle School #11
January 31, 2025
V_EXH36_TEMP CONST ESMT_02301202

Temporary Construction Easement Description:

All that part of Lot 1, together with part of Tract A, together with part of Tract B, Blue Valley Middle School #11, a subdivision in the City of Overland Park, Kansas, all lying in the North Half of Section 25, Township 14 South, Range 24 East, more particularly described by Michael J. Bogina, Kansas PS-1655 of Olsson, Inc., LS-114, on January 31, 2025, as follows:

BEGINNING at the Northeast corner of said Tract B; thence South 02 degrees 12 minutes 34 seconds East, on the East line of said Tract B, a distance of 30.00 feet to a point; thence South 88 degrees 02 minutes 46 seconds West, departing said East line, a distance of 432.62 feet to a point; thence South 41 degrees 25 minutes 06 seconds West a distance of 172.48 feet to a point; thence North 76 degrees 10 minutes 13 seconds West a distance of 30.00 feet to a point; thence North 28 degrees 44 minutes 50 seconds West a distance of 131.31 feet to a point; thence South 88 degrees 02 minutes 46 seconds West a distance of 432.89 feet to a point; thence South 88 degrees 02 minutes 44 seconds West a distance of 605.18 feet to a point on the West line of said Lot 1; thence North 02 degrees 19 minutes 10 seconds West, on said West line, a distance of 30.00 feet to the Northwest corner of said Lot 1, said point also lying on the South line of 175th Street right of way, as established in said Blue Valley Middle School #11; thence North 88 degrees 02 minutes 44 degrees East, departing said West line, on said South line, a distance of 605.37 feet to a point; thence North 88 degrees 02 minutes 46 seconds East, continuing on said South line, a distance of 1071.88 feet to the POINT OF BEGINNING, containing 64,713 Square Feet or 1.4856 Acres, more or less.

(As depicted on EXHIBIT "A", Page 2 of 2, attached and incorporated herein.)



DWG: F:\2021\03001-03500\021-03344\40-Design\Survey\SRV\1\Sheets\1\TEMP CONST ESMT_02103344.dwg USER: mjbogina
 DATE: Jan 31, 2025 5:30pm XREFS:

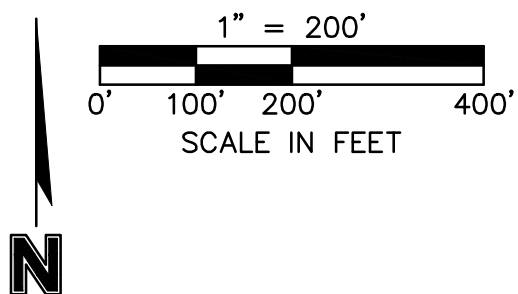

Area: 64,713 S.F.
 1.4856 Ac., ±

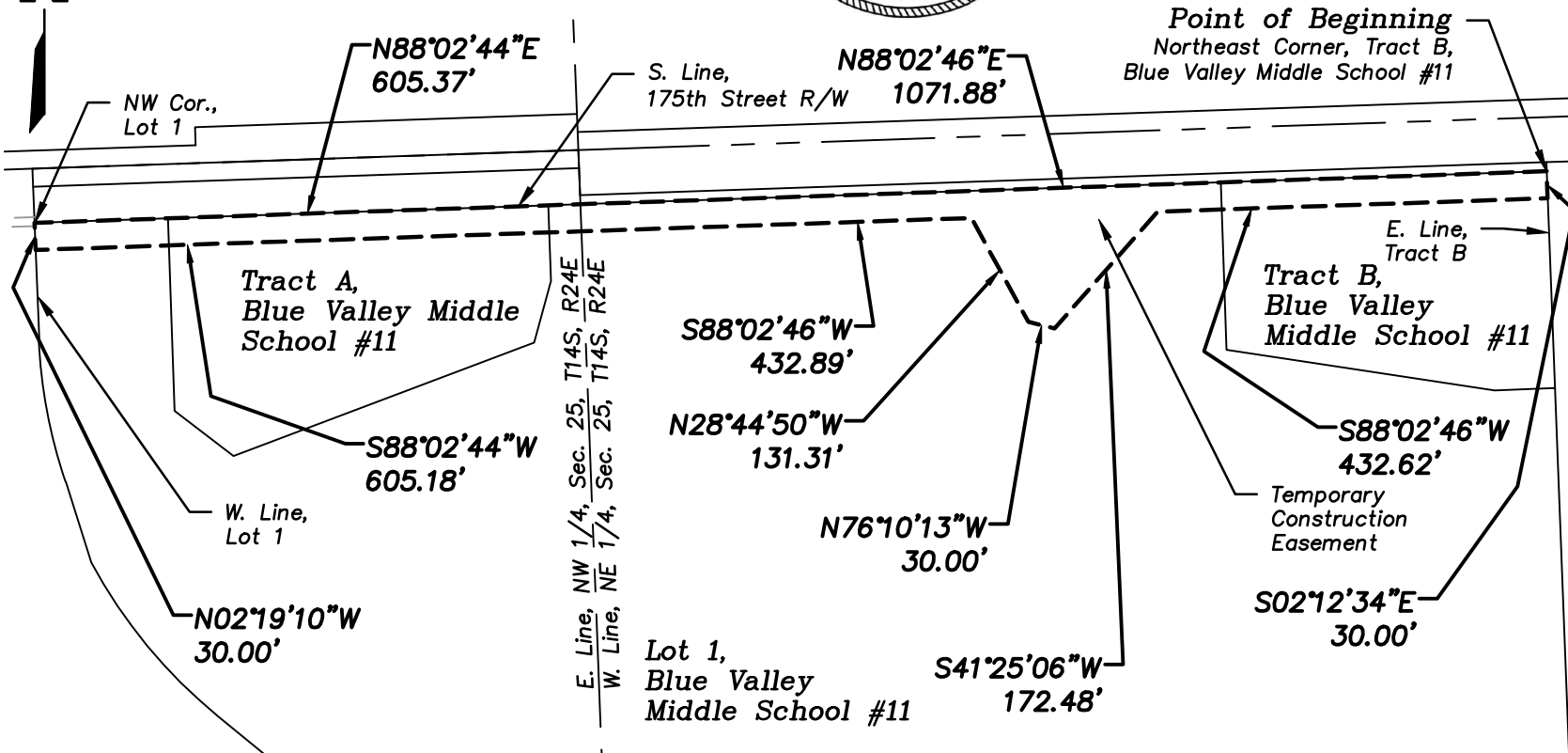

PROJECT NO:	023-01202
DRAWN BY:	TWT
DATE:	01-31-2025

**Temporary Construction
 Easement Exhibit**

olsson

7301 West 133rd Street
 Suite 200
 Overland Park, KS 66213-4750
 TEL 913.381.1170

EXHIBIT
 "A"
 (Page
 2 of 2)



PURCHASING UNIVERSAL REQUEST

BLUE VALLEY SCHOOL DISTRICT #229

Department/Bldg.:	Facilities and Operations	Requested By:	Jake Slobodnik
Purpose: (please explain in detail why we need the items or services requested)			
<p><i>UTILITY EASEMENT AGREEMENT- Private Service Line at Blue Valley Recreation Activity Center</i></p> <p><i>This agreement is between Blue Valley School District and the City of Overland Park to dedicate a private water service line easement to the water utility company, WaterOne. This easement is related to the expansion of the Blue Valley Recreation Activity Center.</i></p>			
Fund:	NA	Account Number:	NA
Funding Year:	2025/2026	Location(s) items or services are for:	BVRC
Does this use Bond Funds? (if yes, see below)		No	
<input type="checkbox"/> This request includes extended warranty, service or maintenance. Please complete the <u>Bond Warranty Agreement Form on page 2</u>		<input type="checkbox"/> This request includes training or consultation. Please complete <u>Bond Consultant Services Form on Page 3</u>	

Check all that apply to this Purchase:

- | | |
|--|--|
| <input checked="" type="checkbox"/> This is a New Contract | <input type="checkbox"/> This is a New Bid/RFP |
| <input type="checkbox"/> This is a Renewal Contract | <input type="checkbox"/> This is a Purchase from Bid/RFP # _____ |
| <input type="checkbox"/> This is a Curriculum purchase | <input type="checkbox"/> This Purchase requires BOE Signatures |
| <input type="checkbox"/> This can be purchased off of _____ Contract # _____ | |

Begin Date: 8/11/2025	End Date:
Company: City of Overland Park	Street Address: 8500 Santa Fe Drive
Contact Name: Leslie Karr	City: Overland Park
Telephone: (913) 895-6196	State: KS
Email: leslie.karr@opkansas.org	Zip Code: 66212
Cost: \$ 0.00	
Prior Year Cost:	
Terms: (Annual, Multi-Year, One-Time):	

Month:(board meeting) September 2025 **Budget Administrator** Jake Slobodnik **Date** _____

PRIVATE WATER SERVICE LINE

EASEMENT AGREEMENT

THIS EASEMENT AGREEMENT is made and entered into as of the 21 day of August, 2025, by and between Bank of New York Mellon Trust Company NA Trustee, and Unified School District NO 229.

Recitals of Fact

A. Grantor is the fee simple owner of certain real property situated in the City of Overland Park, Johnson County, Kansas, as depicted on **Exhibit "B"** attached hereto and incorporated herein by this reference "the **"Servient Tenement"**").

B. Grantee is the fee simple owner of certain real property situated in the City of Overland Park, Johnson County, Kansas, as depicted on on **Exhibit "C"** attached hereto and incorporated herein by this reference "the **"Dominant Tenement"**").

C. Grantor desires to grant to Grantee and Grantee desires to receive from Grantor an exclusive easement for the benefit of Grantee, lying over the Servient Tenement and serving the Dominant Tenement.

Agreement

NOW, THEREFORE, in consideration of the mutual promises and agreements contained herein and in consideration of the payment to Grantor by Grantee of the sum of Ten and no/100 Dollars, the receipt and sufficiency of which is hereby acknowledged by Grantor, and for other good and valuable consideration, Grantor and Grantee hereby grant, covenant and agree as follows:

1. **Representation and Warranty.** Grantor hereby represents and warrants that it has full right and authority to convey the easement rights which this Easement Agreement purports to convey upon the terms stated in this Easement Agreement.

2. **Grant of Easement.** Grantor hereby grants, bargains, sells and conveys to Grantee, its successors and assigns, an exclusive easement over, upon, across and under the real property legally described and depicted in **Exhibit "A"** attached hereto and incorporated herein by this reference (the **"Easement Tract"**) with the right to erect, construct, grade, and install, and thereafter use, operate, repair, maintain and replace a domestic water service line and a fire protection water service line (hereinafter **"Improvements"**). This easement shall encumber the Servient Tenement and shall bind all future owners of all or any part of the Servient Tenement which the easement affects. This easement is appurtenant to the Dominant Tenement, shall benefit the Dominant Tenement, and shall "run with the land" and inure to the benefit of all future owners of all or any part of the Dominant Tenement.

3. **Easement Drawing.** Also included on Exhibit "C" or attached as a separate Exhibit "D" is a drawing showing the complete dimensions of the easement as legally described and the dimensioned relationship to the property lines of the Grantor's and the Grantee's property lines.

4. **Duration and Termination.** This Easement Agreement shall be perpetual in duration.

5. **Construction of Improvements.** Grantee agrees that at the sole cost and expense of the Grantee, Grantee may erect, construct, install, and lay the Improvements.

6. **Damage to Property.** Grantor and Grantee acknowledge and agree that any and all damage to the property of Grantor which is caused by the construction, installation, or operation of the Improvements, shall be repaired at the sole cost and expense of and by the Grantee.

7. **Maintenance and Repair.** Grantee shall be responsible for all maintenance and repair of the Improvements, and all insurance of the Improvements, during the term of the Easement Agreement. Grantor shall have no responsibility or liability for any such matters whatsoever.

8. **Successors and Assigns.** This Easement Agreement shall be binding upon the parties hereto, their successors and assigns, including without limitation future owner(s) of all or any portion of the Dominant Tenement and the Servient Tenement as set forth in Section 2 above, and shall inure to the benefit of the Grantee, its employees, contractors, tenants, licensees, agents and invitees.

9. **Miscellaneous.** This Agreement shall be governed by the laws of the State of Kansas. The captions of the paragraphs of this Agreement are inserted for convenience only and shall not be used in the interpretation hereof. If any provisions hereof are found unenforceable, the remaining provisions of this Agreement shall remain in full force and effect and shall be enforceable to the extent unaffected.

IN WITNESS WHEREOF, the parties hereto, intending to be fully and absolutely bound hereby, have executed this Easement Agreement as of the day and year first above written.

Grantor:

By: [Signature]

Print Name: Quintanna L. Walker
Vice President

Print Title: _____

STATE OF NEW YORK)
) ss:
COUNTY OF NEW YORK)

BE IT REMEMBERED, that on this 21st day of AUGUST, 2025, before me, the undersigned, A Notary Public in and for the County and State aforesaid, personally appeared Quintanna L. Walker, who is personally known to me to be the same person who executed the within instrument of writing, and duly acknowledged the execution of the same.

IN WITNESS WHEREOF, I have hereunto set my hand and affixed my official seal the day and year first above written.

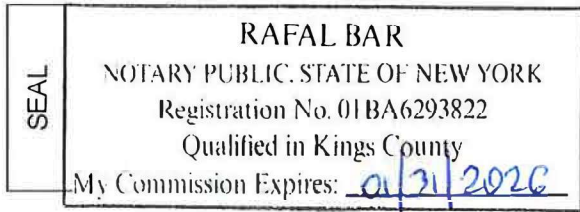

[Signature]
NOTARY PUBLIC SIGNATURE

My appointment expires:

01/31/2026

Grantee:

By: _____

Print Name: _____

Print Title: _____

STATE OF _____)
) ss:
COUNTY OF _____)

BE IT REMEMBERED, that on this _____ day of _____, 20____, before me, the undersigned, A Notary Public in and for the County and State aforesaid, personally appeared _____, who is personally known to me to be the same person who executed the within instrument of writing, and duly acknowledged the execution of the same.

IN WITNESS WHEREOF, I have hereunto set my hand and affixed my official seal the day and year first above written.



NOTARY PUBLIC SIGNATURE

My appointment expires:

EXHIBIT "A"
(Page 1 of 3)

File No. 024-03492
Blue Valley Aquatic Center
July 9, 2025
V_EXH5_02403492

Water Utility Easement Description:

All that part of an unplatted tract of land, lying in the Northwest Quarter of Section 8, Township 14 South, Range 25 East, in the City of Overland Park, Johnson County, Kansas, described by Michael J. Bogina, Kansas PS-1655, of Olsson, KSLs-114, on July 9, 2025, as follows:

COMMENCING at the Northeast corner of Lot 1, Blue Valley Aquatic Center, a subdivision in the City of Overland Park, Johnson County, Kansas, said corner also lying on the South line of 151st Street right-of-way, as established in Book 6245, Page 124; thence South 02 degrees 10 minutes 09 seconds East, on the East line of said Lot 1, a distance of 15.00 feet to a point, said point being the POINT OF BEGINNING; thence North 87 degrees 40 minutes 15 seconds East, departing the East line of said Lot 1, a distance of 28.79 feet to a point; thence South 02 degrees 19 minutes 45 seconds East, a distance of 115.84 feet to a point; thence South 30 degrees 12 minutes 58 seconds West, a distance of 54.36 feet to a point to be known as Point "A" on said East line of said Lot 1; thence North 02 degrees 10 minutes 09 seconds West, on said East line, a distance of 28.01 feet to a point; thence North 30 degrees 12 minutes 58 seconds East, departing the East line of said Lot 1, a distance of 26.33 feet to a point; thence North 02 degrees 19 minutes 45 seconds West, a distance of 84.64 feet to a point; thence South 87 degrees 40 minutes 16 seconds West to a point on the East line of said Lot 1, a distance of 13.87 feet; thence North 02 degrees 10 minutes 09 seconds West on the East line of said Lot 1, a distance of 26.82 feet to the POINT OF BEGINNING, containing 2,680.80 Square Feet or 0.0615 Acres, more or less.

AND

COMMENCING at Point "A" on said East line of said Lot 1, Blue Valley Aquatic Center; thence South 02 degrees 10 minutes 09 seconds East on the East line of said Lot 1, a distance of 59.24 feet to a point, said point being the POINT OF BEGINNING; thence South 47 degrees 48 minutes 55 seconds East, departing the East line of said Lot 1, a distance of 21.90 feet to a point; thence North 87 degrees 21 minutes 56 seconds East, a distance of 39.27 feet to a point; thence South 02 degrees 38 minutes 04 seconds East, a distance of 21.43 feet to a point; thence South 87 degrees 21 minutes 56 minutes West, a distance of 10.00 feet to a point; thence North 02 degrees 38 minutes 04 minutes West, a distance of 11.43 feet to a point; thence South 87 degrees 21 minutes 56 seconds West, a distance of 33.39 feet to a point; thence North 47 degrees 48 minutes 55 seconds West a distance of 16.24 feet to a point on the East line of said Lot 1,; thence North

02 degrees 10 minutes 09 seconds West on the East line of said Lot 1, a distance of 13.99 feet to the POINT OF BEGINNING, containing 718.30 Square Feet or 0.0165 Acres, more or less.

Aggregate total of 3,398.90 Square Feet or 0.0780 Acres.

(As depicted on EXHIBIT "A" (Page 2 of 2), attached and incorporated herein.)



F:\2024\103001-035001024-03492\40-Design\Survey\SRVY\Xref\BVRAC SITE CAD - 07.09.2025 CLH.dwg
 DATE: Jul 29, 2025 8:42am USER: cheller2

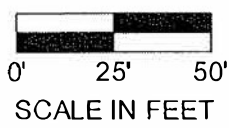
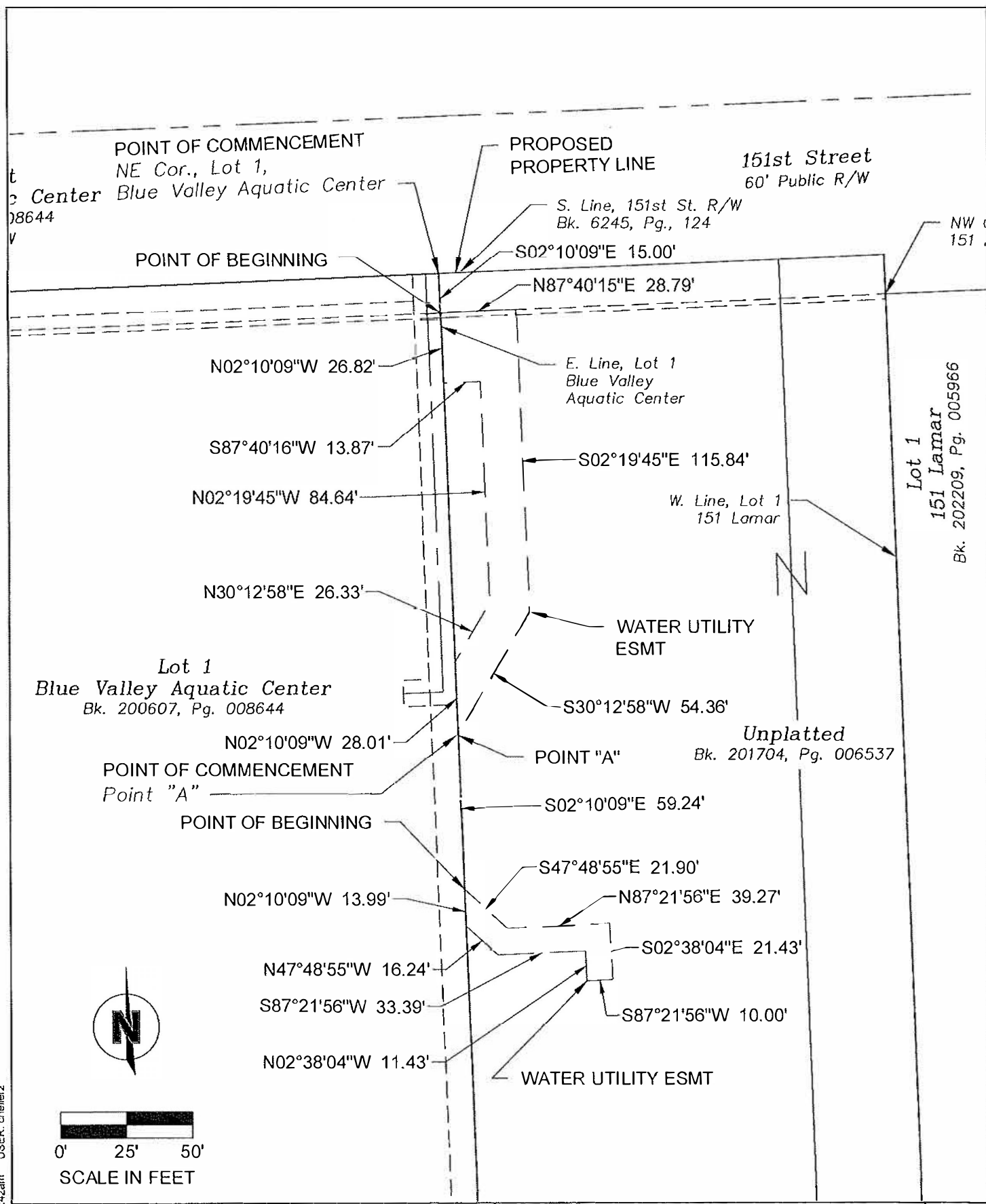

PROJECT NO:	024-03492
DRAWN BY:	CLH
DATE:	07.11.2025

**WATER UTILITY
 EASEMENT**



7301 West 133rd Street
 Suite 200
 Overland Park, KS 66213
 olsson.com
 TEL 913.381.1170
 Olsson - Survey
 Kansas COA #LS-114

EXHIBIT	A
---------	---



PURCHASING UNIVERSAL REQUEST

BLUE VALLEY SCHOOL DISTRICT #229

Department/Bldg.:	Facilities & Operations	Requested By:	Caleb Clements
Purpose: (please explain in detail why we need the items or services requested)			
Playground/Athletic Field Turf Repairs and Cleaning - District wide.			
Playground (account 23990) \$20,000.00			
Athletic Fields (account 23901) \$20,000.00			
Fund:	Capital Outlay	Account Number:	various
Funding Year:	2025/2026	Location(s) items or services are for:	District Wide
Does this use Bond Funds? (if yes, see below)		Yes	
<input type="checkbox"/> This request includes extended warranty, service or maintenance. Please complete the <u>Bond Warranty Agreement Form on page 2</u>		<input type="checkbox"/> This request includes training or consultation. Please complete <u>Bond Consultant Services Form on Page 3</u>	

Check all that apply to this Purchase:

- | | |
|--|--|
| <input type="checkbox"/> This is a New Contract | <input type="checkbox"/> This is a New Bid/RFP |
| <input type="checkbox"/> This is a Renewal Contract | <input type="checkbox"/> This is a Purchase from Bid/RFP # _____ |
| <input type="checkbox"/> This is a Curriculum purchase | <input type="checkbox"/> This Purchase requires BOE Signatures |
| <input type="checkbox"/> This can be purchased off of _____ Contract # _____ | |

Begin Date: 8/27/2025	End Date: 6/30/2026
Company: Fix a Field, LLC	Street Address: PO Box 881
Contact Name: Brandon	City: Baldwin
Telephone: (785) 766-3634	State: KS
Email: brandon@fixafieldllc.com	Zip Code: 66006
Cost: \$ 40,000.00 Estimated	
Prior Year Cost:	
Terms: (Annual, Multi-Year, One-Time):	

Month:(board meeting) September 2025 **Budget Administrator** Jake Slabodnik **Date** 8/27/2025



PURCHASING UNIVERSAL REQUEST

BLUE VALLEY SCHOOL DISTRICT #229

Department/Bldg.:	SPED	Requested By:	Dr. Mark Schmidt
Purpose: (please explain in detail why we need the items or services requested)			
Contracted Level 4 ASL interpreting services for student GM at BVM.			
Fund:	Special Education	Account Number:	30260
Funding Year:	2025/2026	Location(s) items or services are for:	BVM
Does this use Bond Funds? (if yes, see below)			
<input type="checkbox"/> This request includes extended warranty, service or maintenance. Please complete the <u>Bond Warranty Agreement Form on page 2</u>		<input type="checkbox"/> This request includes training or consultation. Please complete <u>Bond Consultant Services Form on Page 3</u>	

Check all that apply to this Purchase:

- | | |
|--|--|
| <input type="checkbox"/> This is a New Contract | <input type="checkbox"/> This is a New Bid/RFP |
| <input checked="" type="checkbox"/> This is a Renewal Contract | <input type="checkbox"/> This is a Purchase from Bid/RFP # _____ |
| <input type="checkbox"/> This is a Curriculum purchase | <input type="checkbox"/> This Purchase requires BOE Signatures |
| <input type="checkbox"/> This can be purchased off of _____ Contract # _____ | |

Begin Date: 9/1/2025	End Date: 6/30/2026
Company: Interpreting Solutions LLC	Street Address: 31348 S Loop
Contact Name: Wendy Bertone	City: Grove
Telephone: (913) 980-4120	State: OK
Email: wendy.bertone@yahoo.com	Zip Code: 74344
Cost: \$ 80,000.00 Estimated	
Prior Year Cost: n/a	
Terms: (Annual, Multi-Year, One-Time): Annual	

Month:(board meeting) September 2025 **Budget Administrator** Dr. Mark Schmidt **Date** 8/26/2025



PURCHASING UNIVERSAL REQUEST

BLUE VALLEY SCHOOL DISTRICT #229

Department/Bldg.:	Career Ready Programs	Requested By:	Adam Wessel
Purpose: (please explain in detail why we need the items or services requested)			
This is an extension of the MOU for our Career Ready partnership with Johnson County Community College. This partnership allows high school juniors and seniors to attend courses at JCCC.			
Fund:	General Fund ▼	Account Number:	034000051-5603
Funding Year:	2025/2026 ▼	Location(s) items or services are for:	
Does this use Bond Funds? (if yes, see below)		No ▼	
<input type="checkbox"/> This request includes extended warranty, service or maintenance. Please complete the <u>Bond Warranty Agreement Form on page 2</u>		<input type="checkbox"/> This request includes training or consultation. Please complete <u>Bond Consultant Services Form on Page 3</u>	

Check all that apply to this Purchase:

- | | |
|--|--|
| <input type="checkbox"/> This is a New Contract | <input type="checkbox"/> This is a New Bid/RFP |
| <input checked="" type="checkbox"/> This is a Renewal Contract | <input type="checkbox"/> This is a Purchase from Bid/RFP # _____ |
| <input type="checkbox"/> This is a Curriculum purchase | <input type="checkbox"/> This Purchase requires BOE Signatures |
| <input type="checkbox"/> This can be purchased off of _____ Contract # _____ | |

Begin Date: 8/1/2025	End Date: 7/31/2026
Company: Johnson County Community College	Street Address: 12345 College Blvd.
Contact Name: Amy Sellers	City: Overland Park
Telephone: (913) 469-8500	State: KS
Email: aseller3@jccc.edu	Zip Code: 66210
Cost:	\$ 450,000.00
Prior Year Cost:	\$ 310,088.68
Terms: (Annual, Multi-Year, One-Time): Annual ▼	

Month:(board meeting) September 2025 **Budget Administrator** Adam Wessel **Date** 8/18/2025



PURCHASING UNIVERSAL REQUEST

BLUE VALLEY SCHOOL DISTRICT #229

Department/Bldg.:	SPED	Requested By:	Dr. Mark Schmidt
Purpose: (please explain in detail why we need the items or services requested)			
This is for an LPN to provide nursing services for student (AW) at ACCESS.			
Fund:	Special Education	Account Number:	26088
Funding Year:	2025/2026	Location(s) items or services are for:	ACCESS
Does this use Bond Funds? (if yes, see below)		No	
<input type="checkbox"/> This request includes extended warranty, service or maintenance. Please complete the <u>Bond Warranty Agreement Form on page 2</u>		<input type="checkbox"/> This request includes training or consultation. Please complete <u>Bond Consultant Services Form on Page 3</u>	

Check all that apply to this Purchase:

- | | |
|--|--|
| <input type="checkbox"/> This is a New Contract | <input type="checkbox"/> This is a New Bid/RFP |
| <input checked="" type="checkbox"/> This is a Renewal Contract | <input type="checkbox"/> This is a Purchase from Bid/RFP # _____ |
| <input type="checkbox"/> This is a Curriculum purchase | <input type="checkbox"/> This Purchase requires BOE Signatures |
| <input type="checkbox"/> This can be purchased off of _____ Contract # _____ | |

Begin Date: 8/12/2025	End Date: 6/30/2026
Company: Maxim Healthcare Services Inc	Street Address: 10881 Lowell, Ste 100
Contact Name: Hal Oberholzer	City: Overland Park
Telephone: (316) 201-9401	State: KS
Email: haoberho@maxhealth.com	Zip Code: 66210
Cost: \$ 72,000.00 Estimated	
Prior Year Cost: N/A	
Terms: (Annual, Multi-Year, One-Time): Annual	

Month:(board meeting) September 2025 **Budget Administrator** Dr. Mark Schmidt **Date** 8/6/2025



PURCHASING UNIVERSAL REQUEST

BLUE VALLEY SCHOOL DISTRICT #229

Department/Bldg.:	SPED	Requested By:	Dr. Mark Schmidt
Purpose: (please explain in detail why we need the items or services requested)			
A nurse (RN) is needed to provide services for a student (BB) at BVN.			
Fund:	Special Education	Account Number:	26088
Funding Year:	2025/2026	Location(s) items or services are for:	BVN
Does this use Bond Funds? (if yes, see below)		No	
<input type="checkbox"/> This request includes extended warranty, service or maintenance. Please complete the <u>Bond Warranty Agreement Form on page 2</u>		<input type="checkbox"/> This request includes training or consultation. Please complete <u>Bond Consultant Services Form on Page 3</u>	

Check all that apply to this Purchase:

- | | |
|--|--|
| <input type="checkbox"/> This is a New Contract | <input type="checkbox"/> This is a New Bid/RFP |
| <input checked="" type="checkbox"/> This is a Renewal Contract | <input type="checkbox"/> This is a Purchase from Bid/RFP # _____ |
| <input type="checkbox"/> This is a Curriculum purchase | <input type="checkbox"/> This Purchase requires BOE Signatures |
| <input type="checkbox"/> This can be purchased off of _____ Contract # _____ | |

Begin Date: 8/12/2025	End Date: 6/30/2026
Company: Maxim Healthcare Services Inc	Street Address: 10881 Lowell, Ste 100
Contact Name: Hal Oberholzer	City: Overland Park
Telephone: (316) 201-9401	State: KS
Email: haoberho@maxhealth.com	Zip Code: 66210
Cost: \$ 76,000.00 Estimated	
Prior Year Cost: n/a	
Terms: (Annual, Multi-Year, One-Time): Annual	

Month:(board meeting) August 2025 **Budget Administrator** Dr. Mark Schmidt **Date** 7/15/2025



PURCHASING UNIVERSAL REQUEST

BLUE VALLEY SCHOOL DISTRICT #229

Department/Bldg.:		SPED	Requested By:		Dr. Mark Schmidt
Purpose: (please explain in detail why we need the items or services requested)					
Student (AM) attending KVC Academy for the 25-26 school year per IEP decision.					
Fund:	Special Education		Account Number:	26090	
Funding Year:	2025/2026	<input type="checkbox"/>	Location(s) items or services are for:	KVC Academy	
Does this use Bond Funds? (if yes, see below)			No		
<input type="checkbox"/> This request includes extended warranty, service or maintenance. Please complete the <u>Bond Warranty Agreement Form on page 2</u>			<input type="checkbox"/> This request includes training or consultation. Please complete <u>Bond Consultant Services Form on Page 3</u>		

Check all that apply to this Purchase:

- | | |
|--|--|
| <input checked="" type="checkbox"/> This is a New Contract | <input type="checkbox"/> This is a New Bid/RFP |
| <input type="checkbox"/> This is a Renewal Contract | <input type="checkbox"/> This is a Purchase from Bid/RFP # _____ |
| <input type="checkbox"/> This is a Curriculum purchase | <input type="checkbox"/> This Purchase requires BOE Signatures |
| <input type="checkbox"/> This can be purchased off of _____ Contract # _____ | |

Begin Date: 8/1/2025	End Date: 6/30/2026
Company: Niles Home for Children	Street Address: 21350 W 153rd St
Contact Name: Yahna Gibson	City: Olathe
Telephone: (816) 241-3448	State: KS
Email: ygibson@kvc.org	Zip Code: 66061
Cost: \$ 44,100.00 Estimated	<input type="checkbox"/>
Prior Year Cost: n/a	
Terms: (Annual, Multi-Year, One-Time): Annual	<input type="checkbox"/>

Month:(board meeting) September 2025 **Budget Administrator** Dr. Mark Schmidt **Date**8/21/2025

Education Services Agreement
Between
Blue Valley Schools (Hilltop Learning Center)
and
KVC Behavioral Healthcare Missouri, Inc.

This Education Services Agreement ("Agreement") is entered into on August 1st, 2025, between Blue Valley Schools, a Kansas Public School District ("Client"), and KVC Behavioral Healthcare Missouri, Inc. ("Contractor").

RECITALS

- A. Contractor engages in the business of providing specialized education services to students referred by local school districts.
- B. Client is a Kansas public School District.
- C. Client wishes to engage Contractor to provide certain services with respect to Client's special education program (the "Program"), and Contractor wishes to provide such services, all on the terms set forth below.

AGREEMENT

In consideration of the promises and covenants contained herein, the parties agree as follows:

1. Commencement Date and Term. This Agreement shall commence on August 1st, 2025 (the "Commencement Date") and shall continue until 11:59 p.m. on June 30th, 2026, (the "Term").
2. Services to be provided by Contractor. During the Term of this Agreement, Contractor shall provide educational services in connection with the Individual Education Program ("Services") to students referred and assigned by Client to Contractor. Contractor shall provide the personnel necessary to provide the Services (the "Personnel").
3. Records. Contractor agrees that all files, documents and records or materials created by Contractor while providing the Services during the Term of this Agreement shall be the property of Client. Contractor agrees that upon the expiration or termination of this Agreement for any reason, Contractor shall immediately deliver all such property of Client in its possession to Client. Contractor may retain a copy of all files, documentation and records in its possession. Notwithstanding anything containing herein to the contrary, it is expressly agreed that Contractor shall retain those original records that it is required to maintain by its licensing authorities to include, but not limited to, therapist notes and treatment plans. Client and Contractor shall make a reasonable effort to limit the original records maintained by Contractor.

4. Responsibilities of Client. Prior to the student being enrolled with Contractor, Client will provide a copy of most recent Educational Diagnostic Summary, an IEP developed from that Summary and written for placement in a private separate day school, discipline and attendance records, and any other pertinent information including, but not limited to, information necessary to maintain the health, safety, and security of students and staff of Contractor.

During the Term of this Agreement, Client shall provide Contractor with updated student records, including Individual Education Plans, as may be reasonably necessary for the proper provision of the Services. Client will maintain ownership of the IEP and Educational Evaluation as the LEA (Local Education Authority) and assume responsibility for contents contained within said documents. Contractor will partner with Client to provide necessary data to complete IEP and Educational Evaluation.

If Client intends on using third party vendors in conjunction with services provided by Contractor, Client will obtain written approval from Contractor to allow third party vendors to provide services at Contractor's facilities.

Client shall provide written thirty (30) day notice to Contractor of any intention to discontinue services due to budget constraints. Without written notice, Contractor will continue to provide services and send invoices in accordance with the other terms of this agreement. Any disputes regarding this section will be addressed in accordance with 7d.

5. Additional Responsibilities of Contractor.

- a. Qualifications. Credentials. Licenses. All Contractor Personnel will be qualified in all material respects to provide the Services they provide on behalf of Contractor hereunder. All instructors and therapists provided by Contractor under this Agreement will hold a certification or license issued by the state in which they are providing Services hereunder appropriate for providing the requested Service.
- b. Fingerprinting Requirements. Contractor shall conduct such criminal background checks of all Contractor Personnel through the Missouri Highway Patrol (MHP) as required by applicable law. All employees of Contractor must be authorized to begin work by Missouri Division of Social Services prior to beginning employment with Contractor.
- c. Attendance Reporting. Contractor shall keep accurate records of student attendance. Copies of such records will be provided to Client monthly.
- d. Compliance with Laws. During the term of this Agreement, Contractor shall comply in all respects with all applicable federal and state statutes, laws, regulations, ordinances and rules relating to the provision of special education services.

6. Independent Contractor. The parties hereto acknowledge that Contractor is an Independent Contractor. This Agreement shall not render Contractor an employee, partner, agent of, or joint venture with Client for any purpose. Contractor is and will remain an Independent Contractor in its relationship to Client in connection with this Agreement. Client shall not be responsible for withholding taxes with respect to the Contractor's compensation hereunder. Contractor shall have no claim against Client hereunder or otherwise for vacation pay, sick leave, retirement benefits, social security, worker's compensation, health or disability benefits, unemployment insurance benefits, or employee benefits of any kind.

7. Compensation and Method of Payment. The Compensation shall be payable by Client monthly as follows:

- a) Compensation. The Client agrees to pay the Contractor for services provided at the following rates per student for each day the Client’s student is enrolled with Contractor:

SERVICE	FEE	
Education Services	\$225.00	Per Day of Enrollment
1:1 Paraprofessional (<i>If applicable per IEP</i>)	\$215.00	Per Day of Enrollment
Speech and Language Services/Occupational Therapy Services	\$95.00	Per Hour

- b) Student Absences. Contractor will keep attendance records daily and will provide Client with the attendance record monthly. Absences will be classified as excused or unexcused using the following definition: an “excused absence” shall include any absence due to substantiated medical issues, religious observances, death of an immediate family member, required court appearances and other circumstances which are approved by the student’s parent or guardian; and an “unexcused absence” shall be any absence that is not an excused absence.
- c) Invoice. Within fifteen (15) business days of the last day of each month during the term of this Agreement, Contractor shall submit an invoice to Client for Services provided during such month and attach true and complete copies of the attendance and time records described in Section 5c above. Each undisputed invoice so delivered shall be due and payable in full by Client within thirty (30) calendar days of the date it was submitted, subject to paragraph 7d below.
- d) Payment Disputes. If Client has a bona fide, good faith dispute with respect to whether a particular Service identified in a Contractor invoice hereunder was actually provided in accordance with the terms of this Agreement, Client shall give written notice to Contractor describing such dispute in reasonable detail within thirty (30) calendar days of the date such invoice was received, accompanied by payment in full of all amounts shown on such invoice that are not the subject of the dispute(s) described on such notice. Contractor and Client shall use their best reasonably good faith efforts to resolve such dispute within the thirty (30) calendar day period following such notice. If such dispute cannot be resolved within such thirty (30) day period, either Contractor or Client may terminate this Agreement on not less than forty-five (45) business days' written notice. Termination of this Agreement shall not impact Client’s obligation to pay.

8. Termination. Either party may terminate this Agreement with or without cause at any time prior to its expiration date by providing written notice of intent to terminate thirty (30) days prior to termination to the other party. If such termination occurs, Contractor shall be paid for services rendered through the date of termination. Notwithstanding the foregoing, if Contractor is convicted of any crime or offense, fails or refuses to comply with the written policies or reasonable directives of Client, is guilty of serious misconduct in connection with its

performance hereunder, or materially breaches provisions of this Agreement, Client may terminate the engagement of Contractor without prior written notice to Contractor, and Contractor shall not receive any additional compensation from Client, but for those amounts remaining to be paid for services already rendered.

9. Insurance. Contractor shall procure and maintain throughout the term hereof, and all renewals and extensions hereof:

- a. General Liability. General liability insurance for Contractor Personnel at the school facilities in performance of Contractor's obligations under this Agreement with coverage of not less than One Million dollars (\$1,000,000) for any incident, and Three Million Dollars (\$3,000,000) annual aggregate. Contractor agrees to provide Client with a Certificate of Insurance of such general liability and professional malpractice insurance policy
- b. Worker's Compensation. Worker's Compensation Insurance covering the activities of each Contractor employee providing Services to Client hereunder, which insurance shall comply with all applicable legal requirements.

10. Indemnification. Each Party shall defend, hold harmless, and indemnify the other Party and the governing board, officers, directors, agents, and employees of the other from and against all liabilities and claims for damage for death, sickness, or injury to any person(s) or damage to any property, including, without limitation, all consequential damages and expenses (including attorney fees), from any cause whatsoever arising from or connected with services or referrals hereunder resulting from the negligence or intentional acts of the other Party or their agents, employees or subcontractors. It is understood that such indemnity shall survive the termination of this Agreement.

11. Extended School Year Program. Contractor shall provide Client with a list of students to be serviced during the extended school year program prior to April 30th. Contractor shall obtain written approval from Client prior to providing extended year services to such students.

12. No Third-Party Beneficiaries. The parties intend that the benefits of this Agreement shall inure only to Contractor and Client and not to any third person.

13. Headings. Section headings are not to be considered a part of this Agreement and are not intended to be a full and accurate description of the contents hereof.

14. Waiver. Waiver by one party hereto of breach of any provision of this Agreement by the other shall not operate or be construed as a continuing waiver.

15. Assignment. This Agreement shall be binding upon and shall inure to the benefit of the Parties and their respective successors and permitted assigns. Contractor shall not assign any of its rights under this Agreement or delegate the performance of any of its duties hereunder, without the prior written consent of the Client.

16. Modification or Amendment. No amendment, change or modification of this Agreement shall be valid unless in writing signed by the Parties hereto.

17. Governing Law. This Agreement shall be governed by and construed in accordance with the laws of the State of Missouri.

18. Notices. Any notices required or permitted to be given hereunder by either party to the other shall be in writing and shall be deemed delivered upon personal delivery or delivery by facsimile or electronic mail (provided that, in the case of facsimile the sender shall have obtained electronic or other confirmation of actual delivery, and in the case of electronic mail, the sender shall have delivered to the e-mail address identified below and shall not have received an electronic notice of non-delivery); twenty-four (24) hours following deposit with a courier for overnight delivery; or seventy-two (72) hours following deposit in the U.S. Mail, registered or certified mail, postage prepaid, return-receipt requested.

If to Contractor:

KVC Behavioral HealthCare, Missouri, Inc.
330 N. Gore Ave.
Webster Groves, MO 63119
Attention: Dr. Pam Dawson, Vice President of Education
Telephone: 573-465-3959
Email: pdawson@kvc.org

For Contract Questions/Concerns/Copies:

Heather Kelley
Email: hkelley@kvc.org

If to Client:

Blue Valley Schools (Hilltop Learning Center)
Address: 7700 W 143rd Street
Overland Park, Kansas 66223
Attention: Jennie Perdieu
Telephone: (913) 624-2831
Email: JPerdieu@bluevalleyk12.org

19. Entire Understanding. This document constitutes the entire understanding and agreement of the parties, and any and all prior agreements, understandings, and representations are hereby terminated and canceled in their entirety and are of no further force and effect.

20. Unenforceability of Provisions. If any provision of this Agreement, or any portion thereof, is held to be invalid and unenforceable, then the remainder of this Agreement shall nevertheless remain in full force and effect.

IN WITNESS WHEREOF the undersigned have executed this Agreement as of the day and year first written above.

Client:

Blue Valley Schools (Hilltop Learning Center)

By: _____

Contractor:

KVC Behavioral Healthcare Missouri, Inc.
A Missouri nonprofit corporation

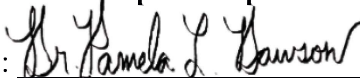
By: 

Dr. Pam Dawson, Vice President, Education



PURCHASING UNIVERSAL REQUEST

BLUE VALLEY SCHOOL DISTRICT #229

Department/Bldg.:	SPED	Requested By:	Dr. Mark Schmidt
Purpose: (please explain in detail why we need the items or services requested)			
Para staffing support to fill a vacancy at BVM for 25-26 school year.			
Fund:	Special Education	Account Number:	30260
Funding Year:	2025/2026	Location(s) items or services are for:	BVM
Does this use Bond Funds? (if yes, see below)		No	
<input type="checkbox"/> This request includes extended warranty, service or maintenance. Please complete the <u>Bond Warranty Agreement Form on page 2</u>		<input type="checkbox"/> This request includes training or consultation. Please complete <u>Bond Consultant Services Form on Page 3</u>	

Check all that apply to this Purchase:

- | | |
|--|--|
| <input type="checkbox"/> This is a New Contract | <input type="checkbox"/> This is a New Bid/RFP |
| <input checked="" type="checkbox"/> This is a Renewal Contract | <input type="checkbox"/> This is a Purchase from Bid/RFP # _____ |
| <input type="checkbox"/> This is a Curriculum purchase | <input type="checkbox"/> This Purchase requires BOE Signatures |
| <input type="checkbox"/> This can be purchased off of _____ Contract # _____ | |

Begin Date: 8/7/2025	End Date: 6/30/2026
Company: ProCare Therapy	Street Address: 1979 Lakeside Pkwy, Ste 800
Contact Name: Alex Sutton	City: Tucker
Telephone: (470) 286-1089	State: GA
Email: alex.sutton@procaretherapy.com	Zip Code: 30084
Cost: \$ 40,000.00 Estimated	
Prior Year Cost: N/A	
Terms: (Annual, Multi-Year, One-Time): Annual	

Month:(board meeting) September 2025 **Budget Administrator** Dr. Mark Schmidt **Date** 8/6/2025

ADDENDUM A
Client Assignment Confirmation



This Client Assignment Confirmation is entered into and executed as of the signature date below and supplements the Client Services Agreement between the Client and New Direction Solutions, LLC dba ProCare Therapy ("ProCare" or "the Company"). Client will pay ProCare for hours worked by Consultant on the following terms:

Assignment Details

ProCare Consultant: Makiah Hudson PID: *

School District Name (Client): Blue Valley Schools - USD 229

Start Date: 08/07/2025 End Date: 05/29/2026

Start and End dates are subject to change based on the credentialing and licensure process as well as adjustment in the school district's calendar.

Position: Paraprofessional

Bill Rate: \$35.00 Minimum Hours: 35

Overtime Rate: 1.5 times Bill Rate

Billing Workweek: Monday – Friday

Miscellaneous: Full Time. 35 Hours Per Week. Hours and Schedule subject to change based on school calendar/district need.

Sales tax or gross receipts tax will be added to professional fees if required or allowed by state law and client is not a tax-exempt entity.

If ProCare Consultant should be required to travel to other locations at the specific request of the Client, the Client will be responsible for all expenses incurred.

Option of virtual services will be offered by ProCare in lieu of onsite services.

All precautions will be taken by the Client to create a safe and healthy environment.

If, within one (1) calendar year of Company introducing or referring a Consultant to Client or the end of a Consultant's assignment with Client, whichever is later, Client hires, contracts with, or refers a Consultant to a third-party Client agrees this constitutes a permanent placement and agrees to compensate Company for its time and efforts. The compensation owed to Company for a permanent placement as described in this section shall be the greater of: (i) Twenty-Two Thousand Five Hundred Dollars (\$22,500), or (ii) Thirty-Five Percent (35%) of the Consultant's first-year compensation from Client or third-party. For purposes of this clause, "introduce" and "refer" shall include any instance where Client has received information about a Consultant from Company or has interviewed, communicated with, or otherwise engaged in discussions with a Consultant as a result of Company's services. The parties agree that this section is intended to provide fair compensation to Company for its services, and it does not, in any way, restrict Client's right to hire a Consultant introduced or referred by Company.

Account Representative Information: Alex Sutton
alex.sutton@procaretherapy.com
4702861089

By: 108039 - Blue Valley Schools - USD 229

Print Name: _____

Title: _____

Date: _____

***Terms and conditions outlined in this Client Assignment Confirmation will be considered agreed upon by all parties unless ProCare is notified of changes by Client within forty-eight (48) hours of client's receipt of this Client Assignment Confirmation.**



PURCHASING UNIVERSAL REQUEST

BLUE VALLEY SCHOOL DISTRICT #229

Department/Bldg.:	SPED	Requested By:	Dr. Mark Schmidt
Purpose: (please explain in detail why we need the items or services requested)			
Para to fill a vacancy at BRE for the 25-26 school year.			
Fund:	Special Education	Account Number:	30260
Funding Year:	2025/2026	Location(s) items or services are for:	BRE
Does this use Bond Funds? (if yes, see below)		No	
<input type="checkbox"/> This request includes extended warranty, service or maintenance. Please complete the <u>Bond Warranty Agreement Form on page 2</u>		<input type="checkbox"/> This request includes training or consultation. Please complete <u>Bond Consultant Services Form on Page 3</u>	

Check all that apply to this Purchase:

- | | |
|--|--|
| <input type="checkbox"/> This is a New Contract | <input type="checkbox"/> This is a New Bid/RFP |
| <input checked="" type="checkbox"/> This is a Renewal Contract | <input type="checkbox"/> This is a Purchase from Bid/RFP # _____ |
| <input type="checkbox"/> This is a Curriculum purchase | <input type="checkbox"/> This Purchase requires BOE Signatures |
| <input type="checkbox"/> This can be purchased off of _____ Contract # _____ | |

Begin Date: 9/2/2025	End Date: 6/30/2026
Company: ProCare Therapy	Street Address: 1979 Lakeside Pkwy, Ste 800
Contact Name: Alex Sutton	City: Tucker
Telephone: (470) 286-1089	State: GA
Email: alex.sutton@procaretherapy.com	Zip Code: 30084
Cost: \$ 40,000.00 Estimated	
Prior Year Cost: n/a	
Terms: (Annual, Multi-Year, One-Time): Annual	

Month:(board meeting) September 2025 **Budget Administrator** Dr. Mark Schmidt **Date** 8/21/2025

ADDENDUM A
Client Assignment Confirmation



This Client Assignment Confirmation is entered into and executed as of the signature date below and supplements the Client Services Agreement between the Client and New Direction Solutions, LLC dba ProCare Therapy ("ProCare" or "the Company"). Client will pay ProCare for hours worked by Consultant on the following terms:

Assignment Details

ProCare Consultant: Noah Markovetz PID: *

School District Name (Client): Blue Valley Schools - USD 229

Start Date: 09/02/2025 End Date: 05/22/2026

Start and End dates are subject to change based on the credentialing and licensure process as well as adjustment in the school district's calendar.

Position: PARA

Bill Rate: \$35.00 Minimum Hours: 35

Overtime Rate: 1.5 times Bill Rate

Billing Workweek: Monday – Friday

Miscellaneous:

*

Sales tax or gross receipts tax will be added to professional fees if required or allowed by state law and client is not a tax-exempt entity.

If ProCare Consultant should be required to travel to other locations at the specific request of the Client, the Client will be responsible for all expenses incurred.

Option of virtual services will be offered by ProCare in lieu of onsite services.

All precautions will be taken by the Client to create a safe and healthy environment.

Should Client desire the convert the Consultant named above from contracted personnel to a direct employee, Client shall reach out to their Company representative for more information.

-

Account Representative Information: Rebecca Brown
rebecca.brown@procaretherapy.com
7703250308

By: 108039 - Blue Valley Schools - USD 229

Print Name: _____

Title: _____

Date: _____

***Terms and conditions outlined in this Client Assignment Confirmation will be considered agreed upon by all parties unless ProCare is notified of changes by Client within forty-eight (48) hours of client's receipt of this Client Assignment Confirmation.**



PURCHASING UNIVERSAL REQUEST

BLUE VALLEY SCHOOL DISTRICT #229

Department/Bldg.:	SPED	Requested By:	Dr. Mark Schmidt
Purpose: (please explain in detail why we need the items or services requested)			
Para to fill a vacancy at OTM for the 25-26 school year.			
Fund:	Special Education	Account Number:	30260
Funding Year:	2025/2026	Location(s) items or services are for:	OTM
Does this use Bond Funds? (if yes, see below)		No	
<input type="checkbox"/> This request includes extended warranty, service or maintenance. Please complete the <u>Bond Warranty Agreement Form on page 2</u>		<input type="checkbox"/> This request includes training or consultation. Please complete <u>Bond Consultant Services Form on Page 3</u>	

Check all that apply to this Purchase:

- | | |
|--|--|
| <input type="checkbox"/> This is a New Contract | <input type="checkbox"/> This is a New Bid/RFP |
| <input checked="" type="checkbox"/> This is a Renewal Contract | <input type="checkbox"/> This is a Purchase from Bid/RFP # _____ |
| <input type="checkbox"/> This is a Curriculum purchase | <input type="checkbox"/> This Purchase requires BOE Signatures |
| <input type="checkbox"/> This can be purchased off of _____ Contract # _____ | |

Begin Date: 9/1/2025	End Date: 6/30/2026
Company: ProCare Therapy	Street Address: 1979 Lakeside Pkwy, Ste 800
Contact Name: Alex Sutton	City: Tucker
Telephone: (470) 286-1089	State: GA
Email: alex.sutton@procaretherapy.com	Zip Code: 30084
Cost: \$ 40,000.00 Estimated	
Prior Year Cost: n/a	
Terms: (Annual, Multi-Year, One-Time): Annual	

Month:(board meeting) September 2025 **Budget Administrator** Dr. Mark Schmidt **Date** 8/21/2025

ADDENDUM A
Client Assignment Confirmation



This Client Assignment Confirmation is entered into and executed as of the signature date below and supplements the Client Services Agreement between the Client and New Direction Solutions, LLC dba ProCare Therapy ("ProCare" or "the Company"). Client will pay ProCare for hours worked by Consultant on the following terms:

Assignment Details

ProCare Consultant: Reagan Hunt PID: *

School District Name (Client): Blue Valley Schools - USD 229

Start Date: 09/01/2025 End Date: 05/22/2026

Start and End dates are subject to change based on the credentialing and licensure process as well as adjustment in the school district's calendar.

Position: PARA

Bill Rate: \$35.00 Minimum Hours: 35

Overtime Rate: 1.5 times Bill Rate

Billing Workweek: Monday – Friday

Miscellaneous:

*

Sales tax or gross receipts tax will be added to professional fees if required or allowed by state law and client is not a tax-exempt entity.

If ProCare Consultant should be required to travel to other locations at the specific request of the Client, the Client will be responsible for all expenses incurred.

Option of virtual services will be offered by ProCare in lieu of onsite services.

All precautions will be taken by the Client to create a safe and healthy environment.

Should Client desire the convert the Consultant named above from contracted personnel to a direct employee, Client shall reach out to their Company representative for more information.

-

Account Representative Information: Rebecca Brown
rebecca.brown@procaretherapy.com
7703250308

By: 108039 - Blue Valley Schools - USD 229

Print Name: _____

Title: _____

Date: _____

***Terms and conditions outlined in this Client Assignment Confirmation will be considered agreed upon by all parties unless ProCare is notified of changes by Client within forty-eight (48) hours of client's receipt of this Client Assignment Confirmation.**



PURCHASING UNIVERSAL REQUEST

BLUE VALLEY SCHOOL DISTRICT #229

Department/Bldg.:	SPED	Requested By:	Dr. Mark Schmidt
Purpose: (please explain in detail why we need the items or services requested)			
A para floater to fill a vacancy for the 2025-26 school year.			
Fund:	Special Education ▼	Account Number:	30260
Funding Year:	2025/2026 ▼	Location(s) items or services are for:	Multiple
Does this use Bond Funds? (if yes, see below)		No	
<input type="checkbox"/> This request includes extended warranty, service or maintenance. Please complete the <u>Bond Warranty Agreement Form on page 2</u>		<input type="checkbox"/> This request includes training or consultation. Please complete <u>Bond Consultant Services Form on Page 3</u>	

Check all that apply to this Purchase:

- | | |
|--|--|
| <input type="checkbox"/> This is a New Contract | <input type="checkbox"/> This is a New Bid/RFP |
| <input checked="" type="checkbox"/> This is a Renewal Contract | <input type="checkbox"/> This is a Purchase from Bid/RFP # _____ |
| <input type="checkbox"/> This is a Curriculum purchase | <input type="checkbox"/> This Purchase requires BOE Signatures |
| <input type="checkbox"/> This can be purchased off of _____ Contract # _____ | |

Begin Date: 9/1/2025	End Date: 7/31/2026
Company: ProCare Therapy	Street Address: 1979 Lakeside Pkwy, Ste 800
Contact Name: Alex Sutton	City: Tucker
Telephone: (470) 286-1089	State: GA
Email: alex.sutton@procaretherapy.com	Zip Code: 30084
Cost: \$ 40,000.00 Estimated	▼
Prior Year Cost: n/a	
Terms: (Annual, Multi-Year, One-Time):	

Month:(board meeting) September 2025 **Budget Administrator** Dr. Mark Schmidt **Date**8/26/2025

ADDENDUM A
Client Assignment Confirmation



This Client Assignment Confirmation is entered into and executed as of the signature date below and supplements the Client Services Agreement between the Client and New Direction Solutions, LLC dba ProCare Therapy ("ProCare" or "the Company"). Client will pay ProCare for hours worked by Consultant on the following terms:

Assignment Details

ProCare Consultant: Taylor Dawson PID: *

School District Name (Client): Blue Valley Schools - USD 229

Start Date: 09/08/2025 End Date: 05/29/2026

Start and End dates are subject to change based on the credentialing and licensure process as well as adjustment in the school district's calendar.

Position: Paraprofessional

Bill Rate: \$35.00 Minimum Hours: 35

Overtime Rate: 1.5 times Bill Rate

Billing Workweek: Monday – Friday

Miscellaneous: Full Time. 35 Hours Per Week. Hours and Schedule subject to change based on school calendar/district need.

Sales tax or gross receipts tax will be added to professional fees if required or allowed by state law and client is not a tax-exempt entity.

If ProCare Consultant should be required to travel to other locations at the specific request of the Client, the Client will be responsible for all expenses incurred.

Option of virtual services will be offered by ProCare in lieu of onsite services.

All precautions will be taken by the Client to create a safe and healthy environment.

Should Client desire the convert the Consultant named above from contracted personnel to a direct employee, Client shall reach out to their Company representative for more information.

-

Account Representative Information: Alex Sutton
alex.sutton@procaretherapy.com
4702861089

By: 108039 - Blue Valley Schools - USD 229

Print Name: _____

Title: _____

Date: _____

***Terms and conditions outlined in this Client Assignment Confirmation will be considered agreed upon by all parties unless ProCare is notified of changes by Client within forty-eight (48) hours of client's receipt of this Client Assignment Confirmation.**



PURCHASING UNIVERSAL REQUEST

BLUE VALLEY SCHOOL DISTRICT #229

Department/Bldg.:	ITS	Requested By:	Tyler Davis
Purpose: (please explain in detail why we need the items or services requested)			
<p>26-009 IDM Renewal Purpose: This purchase is for Microsoft Active Directory Enterprise license Subscription. The software takes accounts from Synergy and BPlus and creates them in Office 365, Google, Active Directory, etc.</p>			
Fund:	Capital Outlay	Account Number:	34801
Funding Year:	2025/2026	Location(s) items or services are for:	SSC
Does this use Bond Funds? (if yes, see below)		No	
<input type="checkbox"/> This request includes extended warranty, service or maintenance. Please complete the <u>Bond Warranty Agreement Form on page 2</u>		<input type="checkbox"/> This request includes training or consultation. Please complete <u>Bond Consultant Services Form on Page 3</u>	

Check all that apply to this Purchase:

- | | |
|--|--|
| <input type="checkbox"/> This is a New Contract | <input type="checkbox"/> This is a New Bid/RFP |
| <input checked="" type="checkbox"/> This is a Renewal Contract | <input type="checkbox"/> This is a Purchase from Bid/RFP # _____ |
| <input type="checkbox"/> This is a Curriculum purchase | <input type="checkbox"/> This Purchase requires BOE Signatures |
| <input type="checkbox"/> This can be purchased off of _____ | Contract # _____ |

Begin Date: 11/1/2025	End Date: 10/31/2026
Company: SoftwareIDM Inc.	Street Address: 110 Front St Ste 300
Contact Name: Todd Mollerup	City: Jupiter
Telephone: (331) 218-0001	State: FL
Email: customerservice@softwareidm.com	Zip Code: 33477
Cost:	\$ 45,000.00
Prior Year Cost:	\$45,000.00
Terms: (Annual, Multi-Year, One-Time): Annual	

Month:(board meeting) September 2025 **Budget Administrator** Brian Daley **Date** 8/1/2025



SoftwareIDM
 110 Front St Ste 300
 Jupiter Florida 33477-5095
 U.S.A

LICENSING AND SERVICES QUOTE

Blue Valley Schools

Blue Valley Schools
 P.O. Box 23901
 Overland Park, Kansas 66283

ESTIMATE: Q-US-25-000399

Estimate Date	Expiry Date	Reference#	Sales person	Quote	Customer Contact
07/02/25	08/11/25	BVSD - 2025/26 Renewal	Todd Mollerup	BVSD - 2025/26 Renewal	Tyler Davis

#	Item & Description	Qty	Rate	Amount
1	DESCRIPTION: Annual SaaS Subscription to the SoftwareIDM Identity Panel Suite including applications Identity Panel, Test Panel, Service Panel, Access Panel, and HyperSync. All Providers (connectors) included. Three hosting tenants (Development, QA or UAT, and Production) included. BVSD NFP/School Price: \$45,000 Subscription Term: November 1, 2025 - October 31, 2026	1.00	45,000.00	45,000.00

Applications Subscription Licenses - 1YR

2	Annual Subscription - Application Identity Panel Annual Subscription for Identity Panel Application and framework - Required - Subscription - Time Traveler, Reporting, Dashboards, Health Checks, Workflows, Scheduler, Security, messaging, and more. https://product.softwareidm.com/hc/en-us/articles/360042443854 Subscription Term: November 1, 2025 - October 31, 2026	1.00 yr	0.00	0.00
3	Annual Subscription - Application Test Panel Annual Subscription to Test Panel. Automated regression and integration testing (requires Identity Panel). https://product.softwareidm.com/hc/en-us/articles/360042444474-Test-Panel-App Subscription Term: November 1, 2025 - October 31, 2026	1.00 yr	0.00	0.00
4	Annual Subscription - Application HyperSync Panel Annual Subscription for Synchronization Engine for the Enterprise. Product Description: https://product.softwareidm.com/hc/en-us/articles/1500002179802-HyperSync-Panel-App Subscription Term: November 1, 2025 - October 31, 2026	1.00 yr	0.00	0.00

#	Item & Description	Qty	Rate	Amount
5	Annual Subscription - Application Service Panel Annual Subscription for Service Panel. Identity portal for the enterprise. Product Description: https://product.softwareidm.com/hc/en-us/articles/360042942513-Service-Panel-App Subscription Term: November 1, 2025 - October 31, 2026	1.00 yr	0.00	0.00
6	Annual Subscription - Application Access Panel Annual Subscription for Access Panel - ABAC, RBAC, and Attestation Entitlement management, including criteria based groups, plus just-in-time access/PAM. Product description: https://product.softwareidm.com/hc/en-us/articles/360042444454 Subscription Term: November 1, 2025 - October 31, 2026	1.00 yr	0.00	0.00
Provider (Connectors) Subscription Licenses - 1YR				
7	Annual Subscription - Connect License for Microsoft EntraID Annual Subscription to connect to a single AzureAD/EntraID/M365 directory, Including Panel Provider for a AzureAD/M365/EntraID directory service. PowerShell and GraphAPI provider for Microsoft identity data and provisioning including licensing, Exchange, and AzureAD information. Product Description: https://product.softwareidm.com/hc/en-us/articles/4410991469203-Panel-Provider-for-Microsoft-Entra-Directory Subscription Term: November 1, 2025 - October 31, 2026	1.00 yr	0.00	0.00
8	Annual Subscription - Connect License for Microsoft Active Directory - Enterprise Subscription Annual Subscription to connect to unlimited internal Microsoft Active Directories. Includes data connector for Active Directory that allows unlimited domains to be connected. Unlimited Active Directory domains and forests. Note: Consider single domain licenses if you have less than three domains. https://product.softwareidm.com/hc/en-us/articles/1500002179802-HyperSync-Panel-App Subscription Term: November 1, 2025 - October 31, 2026	1.00 yr	0.00	0.00
9	Annual Subscription - Panel Provider for Microsoft SQL Server - Enterprise Unlimited Subscription - Panel Provider for Microsoft SQL Server. Licenses you to scan, and if applicable, write to Microsoft SQL Server servers or farms Subscription Term: November 1, 2025 - October 31, 2026	1.00 yr	0.00	0.00
10	Annual Subscription - Panel Provider for Delimited File Data connector license for up to ten delimited files. https://product.softwareidm.com/hc/en-us/articles/4410991678355 Subscription Term: November 1, 2025 - October 31, 2026	1.00 yr	0.00	0.00
Hosting				
11		1.00	0.00	0.00

#	Item & Description	Qty	Rate	Amount
	Annual Subscription - Hosting - Capacity Rank 750 12 months of fully managed hosting. Azure cloud. Includes one dedicated App Service instance running one production tenant plus two non-production tenants. Dedicated, compared to shared, adds performance isolation from other customer tenants and adds customer driven change control. High-Availability. Security. Automated Backups. Communication Fee and/or hosted Panel Service additional. Subscription Term: November 1, 2025 - October 31, 2026	yr		
12	Annual Subscription - Panel Service SaaS Data Comm Fee [each] Annual Subscription for Annual Data Communication Fee for one Panel Service from customer network to Azure hosted SaaS, using HTTPS. Subscription Term: November 1, 2025 - October 31, 2026	2.00 ea	0.00	0.00
13	REVIEW NOTE - THE RENEWAL KEYS BELOW MUST BE REVIEWED AND UPDATED	1.00	0.00	0.00
14	Renewal License Keys: Apply only one per environment BVSD - Through October 2025, 1930 Blue Valley School District A9YN6-ZU3E-LFQ8 BVSD - Through October 2025, 1929 Blue Valley School District BX9VG-5XKV-W6WV BVSD - Through October 2025, 1928 Blue Valley School District 74U22-FRCM-HAJK	1.00	0.00	0.00
Sub Total				45,000.00

HOW TO ORDER

Fax, email, or overnight this signed document or your purchase order to:
 SoftwareIDM Inc.
 110 Front St Ste 300
 Jupiter, FL 33477
 Phone (331) 218-0001
 Todd Direct (630) 306-9788
 Peter Direct (630) 605-4522
 orders.distro@softwareidm.com

Total \$45,000.00



PURCHASING UNIVERSAL REQUEST

BLUE VALLEY SCHOOL DISTRICT #229

Department/Bldg.:	BVHS	Requested By:	Kylie Garcia
Purpose: (please explain in detail why we need the items or services requested)			
<p>Nationals Dance Competition Trip February 2/12-2/17/2026 in Orlando, FL. Additional expenses include \$3,500 for ground transportation. Fundraising efforts and individual family contributions will pay for this trip.</p> <p>1) Air Travel- SW Airlines - \$24,125 2) Registration/Lodging - Varsity Spirit- \$32,500</p>			
Fund:	Activity Funds	Account Number:	5205432
Funding Year:	2025/2026	Location(s) items or services are for:	Dance Nationals Trip
Does this use Bond Funds? (if yes, see below)		No	
<input type="checkbox"/> This request includes extended warranty, service or maintenance. Please complete the <u>Bond Warranty Agreement Form on page 2</u>		<input type="checkbox"/> This request includes training or consultation. Please complete <u>Bond Consultant Services Form on Page 3</u>	

Check all that apply to this Purchase:

- | | |
|--|--|
| <input checked="" type="checkbox"/> This is a New Contract | <input type="checkbox"/> This is a New Bid/RFP |
| <input type="checkbox"/> This is a Renewal Contract | <input type="checkbox"/> This is a Purchase from Bid/RFP # _____ |
| <input type="checkbox"/> This is a Curriculum purchase | <input type="checkbox"/> This Purchase requires BOE Signatures |
| <input type="checkbox"/> This can be purchased off of _____ Contract # _____ | |

Begin Date: 02/12/2026	End Date: 02/17/2026
Company: SW Airlines/Varsity Spirit	Street Address:
Contact Name:	City:
Telephone:	State:
Email:	Zip Code:
Cost:	\$ 56,625.00 Estimated
Prior Year Cost:	N/A
Terms: (Annual, Multi-Year, One-Time):	

Month:(board meeting) September 2025 **Budget Administrator** M Ortman **Date** 8/25/2025



PURCHASING UNIVERSAL REQUEST

BLUE VALLEY SCHOOL DISTRICT #229

Department/Bldg.:	Blue Valley High School	Requested By:	Sam Dollins
Purpose: (please explain in detail why we need the items or services requested)			
<p>BVHS choir travel for show choir competition and performance at Walt Disney World Total Travel cost anticipated at \$133,581.95. Families will be responsible for the cost of their student. If fundraising can be done, the cost will be lowered. School personnel travel cost will be wrapped into each of the 75 students' cost. This is NOT a required trip. Optional only</p> <p>Southwest Airlines- \$34,000 Means Transportation- \$12,750 Walt Disney World (lodging): \$35,429.70 Walt Disney World (park tickets): \$39,852.25 FAME (show choir competition host): \$11,250</p> <p style="text-align: right;">FAME (show choir competition registration)- \$11,250</p>			
Fund:	Activity Funds	Account Number:	Choir
Funding Year:	2025/2026	Location(s) items or services are for:	SW Airlines, Means, WDO
Does this use Bond Funds? (if yes, see below)		No	
<input type="checkbox"/> This request includes extended warranty, service or maintenance. Please complete the <u>Bond Warranty Agreement Form on page 2</u>		<input type="checkbox"/> This request includes training or consultation. Please complete <u>Bond Consultant Services Form on Page 3</u>	

Check all that apply to this Purchase:

- | | |
|--|--|
| <input type="checkbox"/> This is a New Contract | <input type="checkbox"/> This is a New Bid/RFP |
| <input type="checkbox"/> This is a Renewal Contract | <input type="checkbox"/> This is a Purchase from Bid/RFP # _____ |
| <input type="checkbox"/> This is a Curriculum purchase | <input type="checkbox"/> This Purchase requires BOE Signatures |
| <input type="checkbox"/> This can be purchased off of _____ Contract # _____ | |

Begin Date: 3/11/2026	End Date: 3/17/2026
Company: SW Airlines/Means Trans/Walt Disney	Street Address:
Contact Name:	City:
Telephone:	State:
Email:	Zip Code:
Cost:	\$ 133,281.95 Estimated
Prior Year Cost:	N/A
Terms: (Annual, Multi-Year, One-Time):	

Month:(board meeting) September 2025 **Budget Administrator** M Ortman **Date** 8/18/25

BLUE VALLEY PUBLIC SCHOOLS' TRIP APPLICATION

(Complete form and submit to principal.)

TRIP INFORMATION

Name of School Blue Valley High school Application Date 7/21/2025

Name of Group/Organization BVHS Choir

Requested by Sam Dollins

Estimated # of Students 75 (Note: Estimate Maximum Number of Students Attending)

Location of Trip Activity Orlando, FL (Universal Studios and Disney World)

Departure Date 3/11/2026

Return Date 3/17/2026

Number of School Day(s) Missed During Travel 1.5

Trip Origination/Termination Point MCI Airport

Plane, Bus (while in Orlando)

Mode of Transportation: (Include specific information - bus, train, plane; company, etc.)

Sam Dollins, Junyi Nie

School Personnel Attending

At least 8 parent chaperones

Non-School School Personnel Attending

Describe curricular value of trip below. (List specific objectives if possible)

This trip offers significant curricular value by providing students with a unique, real-world extension of their classroom learning. Performing at a prestigious venue like Walt Disney World allows students to experience the professional expectations, reinforcing skills in vocal performance, choreography, discipline, and teamwork. Competing nationally (Universal Studios) fosters a spirit of excellence, encouraging students to set and reach high artistic goals while gaining exposure to diverse styles and students from choirs across the country. Additionally, the trip supports social-emotional learning through collaborations, responsibility, and cultural enrichment, making it an invaluable part of a comprehensive music education.

Form A (page 1 of 3)

FINANCIAL INFORMATION

The following tables will be utilized to determine the cost of a trip. Please make note of the following:

- If a student tour company is (or will be) under contract to assist you with the planning of a trip, you must calculate anticipated costs utilizing Table A and B.
- If a student tour company is not involved with the planning of a trip, you do not need to complete Table B. However, you are required to complete Table A.

Are you utilizing a Tour/Travel Company for this trip? No

Table A: Estimate Expenses

Note: 3 blank rows for any other categories of expense not included on this form). Do not include any expenses covered by a student tour company in Table A, these expenses will be calculated in Table B.

Estimated Cost per Participant. Category	#	Cost Per Participant	Cost Extended
Est. Registration Expense	75	150	11250
Est. Travel Expense (to and from destination city)*	85	400	34000
Est. Ground Transportation (in destination city)	85	150	12750
Est. Lodging Expense	85	416.82	35,429.7
Est. Food Expense			0
Est. Miscellaneous Expense **	85	468.85	39852.25
TOTAL			0.00

133,281.95

* Include rental van cost, gasoline, tolls, airline expense, luggage fees, etc.

** Include museum fees, entertainment, etc.

Table B: Estimate Total Cost with Contracted Travel or Tour Company

Note: Please estimate maximum potential participants. (See Step 2 on Page 1 of Packet.)

Category of Participants	#	Cost Per Participant	Cost Extended
Students			0
School Personnel			0
Parent Chaperones			0
Other			0
TOTAL			0

Table C: Total Trip Cost

0

If the School/District is contributing to the trip cost, please enter the total amount here:

133,281.95

This trip will be paid for by individual students and may be offset with any fundraising efforts the group is able to do. The travel cost of the school personnell will be wrapped in the final individual student cost.

Form A (page 2 of 3)

Re: Trip Application

Arrangements: Include all pertinent information - Supervisor-student ratio, schedules, etc. for overnight trips; describe travel arrangements, overnight accommodations, security, additional costs, fundraising, etc. Add additional pages, if necessary.

- Supervision Student Ratio: 6 students to supervisor
- Fly from MCI to MCO on SW airlines
- Ride Means transportation once we arrive in Orlando
- Stay at Pop Century Resort
- Compete at a show choir competition at Universal Studios
- Perform at Walt Disney World
- Got to parks when not competing/performing
- Travel back to airport in Means transportation
- Fly back to MCI on SW Airlines

Approved:

Signature (Principal) _____ Date _____

Signature (Director of School Administration) _____ Date _____

Submitted by: _____ Signature: _____ Date _____

For all signatures you may either utilize a digital signature or you may print document off and sign.

Office Use Only		
	Bus Request Submitted with Application	Date
	Sub Request Submitted with Application	Date

BLUE VALLEY #229 TRIP PARENTAL PERMISSION FORM

This form must be completed, signed by the parent/guardian and returned to the sponsor before a student may participate.

Date 8/14/26

Dear Parents: Our class/group will be taking a trip(s), the details of which are described below.

Destination Orlando, FL Cost Per Student TBD- \$1600-\$1700
 Departure Date 3/11/26 Time AM Parent Permission
 Return Date 3/17/26 Time PM Trip #1
 Origination/Termination Point MCI airport Yes
 Mode of Transportation (i.e., Bus, Private Auto/Van*, Other) Plane/Bus

*Student will be riding with: Sponsor Parent Another Participant

Destination _____ Cost Per Student _____
 Departure Date _____ Time _____ Parent Permission
 Return Date _____ Time _____ Trip #2
 Origination/Termination Point _____ Yes No
 Mode of Transportation (i.e., Bus, Private Auto/Van*, Other) _____

*Student will be riding with: Sponsor Parent Another Participant

Destination _____ Cost Per Student _____ Parent Permission
 Departure Date _____ Time _____ Trip #3
 Return Date _____ Time _____ Yes No
 Origination/Termination Point _____
 Mode of Transportation (i.e., Bus, Private Auto/Van*, Other) _____

*Student will be riding with: Sponsor Parent Another Participant

(If any of these are overnight trips, parents will receive a separate letter(s) from the sponsor outlining all details of the trip.)

Special Notes Regarding Trip(s):

The purpose of this form is to inform you of the above planned activity/activities and obtain your consent. The activity/activities will be supervised by adults. It may be necessary to alter some of the details outlined above, but efforts will be made to retain normal supervision for the safety and welfare of all trip participants.

We would like your student to accompany us on this trip(s) and ask that you sign the permission slip below and return it to us no later than _____. Failure to return this form will prevent your child from participating in the above activity/activities.

I/WE THE UNDERSIGNED, UNDERSTAND THAT Blue Valley School District #229 assumes no responsibility for any and all accidents, damages or other injury which may occur as a passenger, during transit by a private carrier. Full and complete responsibility will be upon the driver of the private carrier, with his/her automobile insurance assuming all liability.

 Student Name (Please Print)

 Parent Signature

 Student Signature (if 18 years old)

 Date

 Phone

NOTE: Students may be sent home at the parent's expense for violating existing Blue Valley District policies or regulations.



PURCHASING UNIVERSAL REQUEST

BLUE VALLEY SCHOOL DISTRICT #229

Department/Bldg.:	SPED	Requested By:	Dr. Mark Schmidt
Purpose: (please explain in detail why we need the items or services requested)			
Contracted SLP to cover for maternity leave at WSE (.4 FTE)			
Fund:	Special Education ▼	Account Number:	30260
Funding Year:	2025/2026 ▼	Location(s) items or services are for:	WSE
Does this use Bond Funds? (if yes, see below)			
<input type="checkbox"/> This request includes extended warranty, service or maintenance. Please complete the <u>Bond Warranty Agreement Form on page 2</u>		<input type="checkbox"/> This request includes training or consultation. Please complete <u>Bond Consultant Services Form on Page 3</u>	

Check all that apply to this Purchase:

- | | |
|--|--|
| <input type="checkbox"/> This is a New Contract | <input type="checkbox"/> This is a New Bid/RFP |
| <input checked="" type="checkbox"/> This is a Renewal Contract | <input type="checkbox"/> This is a Purchase from Bid/RFP # _____ |
| <input type="checkbox"/> This is a Curriculum purchase | <input type="checkbox"/> This Purchase requires BOE Signatures |
| <input type="checkbox"/> This can be purchased off of _____ Contract # _____ | |

Begin Date: 8/10/2025	End Date: 10/15/2025
Company: Supplemental Healthcare Services	Street Address: 6955 S Union Park Center Ste 400
Contact Name: Cahti Rigby	City: Cottonwood Heights
Telephone: (866) 474-6677	State: UT
Email: crigby@shccares.com	Zip Code: 84047
Cost: \$ 36,000.00 Estimated ▼	
Prior Year Cost:	
Terms: (Annual, Multi-Year, One-Time): Annual ▼	

Month:(board meeting) September 2025 **Budget Administrator** Dr. Mark Schmidt **Date**7/21/2025

Wednesday, July 16, 2025

ASHLEY ENZ
BLUE VALLEY- UNIFIED SCHOOL DISTRICT NO. 229
15020 METCALF AVE
OVERLAND PARK, KS 66223

ATTENTION ASHLEY ENZ:

Please accept this letter as verification that Marcia Christie, SLP-CCC, will be extending the contract to work at your facility.

Shift:	7:00AM	Regular Rate:	\$79.00
Unit:	Schools	Overtime Rate:	\$118.50
Start Date:	8/4/2025	Holiday Rate:	\$79.00
End Date:	10/27/2025		
Date of Birth:	08/20/1954		
Time Off:	N/A		
Note:			

Please sign and verify,

Sincerely,

Cathy Rigby

Ashley Enz
Staffing Coordinator

Cathy Rigby
Client Services Director



PURCHASING UNIVERSAL REQUEST

BLUE VALLEY SCHOOL DISTRICT #229

Department/Bldg.:	Human Resources	Requested By:	Eric Punswick
Purpose: (please explain in detail why we need the items or services requested)			
<p>Validity Screening Solutions provides background screening services for the District. The District is renewing services for the 25-26 fiscal year.</p> <p>2024-25 numbers: \$14,500 for certified \$17,320 for classified \$5,550 for guests</p>			
Fund:	Capital Outlay	Account Number:	23018
Funding Year:	2025/2026	Location(s) items or services are for:	Human Resources
Does this use Bond Funds? (if yes, see below)		No	
<input type="checkbox"/> This request includes extended warranty, service or maintenance. Please complete the <u>Bond Warranty Agreement Form on page 2</u>		<input type="checkbox"/> This request includes training or consultation. Please complete <u>Bond Consultant Services Form on Page 3</u>	

Check all that apply to this Purchase:

- | | |
|--|--|
| <input type="checkbox"/> This is a New Contract | <input type="checkbox"/> This is a New Bid/RFP |
| <input checked="" type="checkbox"/> This is a Renewal Contract | <input type="checkbox"/> This is a Purchase from Bid/RFP # _____ |
| <input type="checkbox"/> This is a Curriculum purchase | <input type="checkbox"/> This Purchase requires BOE Signatures |
| <input type="checkbox"/> This can be purchased off of _____ Contract # _____ | |

Begin Date: 7/1/2025	End Date: 6/30/2026
Company: Validity Screening Solutions	Street Address: PO Box 25406
Contact Name: Cathy Newby	City: Overland Park
Telephone: (913) 322-5900	State: KS
Email: cnewby@validityscreening.com	Zip Code: 66225
Cost: \$ 38,000.00 Estimated	
Prior Year Cost: \$ 39,783.50 Estimated	
Terms: (Annual, Multi-Year, One-Time): Annual	

Month:(board meeting) September 2025 **Budget Administrator** EJ Punswick **Date** 8/18/2025

WHAT YOU NEED TO KNOW ABOUT YOUR BACKGROUND CHECK



A bit about us

We're the organization that's been selected to conduct your background check. Organizations across the country trust us with their screening needs. With clients in all 50 states as well as Canada, we've got the capabilities to serve organizations of any size with the same level of industry expertise and dedicated support. You see, we aren't like most screening companies out there. We are a team of dedicated individuals working together to provide employers with the best quality research.



We boast the most accurate data and will return your background check **42% faster** than the industry average



Each report is hand-screened by a Quality Assurance Specialist to ensure that the final report is accurate and actionable



If you ever have a question or concern about your report, our client care team can assist you at 913.322.5999

Compliance counts

Your background check will be handled by a team of screening professionals. Our team members are all trained in Fair Credit Reporting Act (FCRA) compliance and receive a certification from the National Association of Professional Background Screeners (NAPBS). Our top priorities at Validity are our compliance and exceptional client care.



Your background check

Blue Valley School District Service & Pricing:

Criminal OmniSearch-7 (county and/or state search where the candidate has lived for the past 7 years, includes SSN Validation) \$18.00

Surname Surcharge (a full search in any additional legal names used in last 7 years) \$12.00

Multi-State Sex Offender \$5.00

KC Metro Search (automatically added for free for any candidate who has/does live in the KC metro area)

Criminal International - Prices vary depending on country and are only ordered with client approval

Driving Record - Available on account if needed. Prices vary by state.



Human Resources Report to the Board of Education

September 8, 2025

Administration recommends approval of the following actions:

APPOINTMENTS

<u>Name</u>	<u>Location</u>	<u>Position</u>	<u>Effective</u>
HARGER, CARI L	LEAWOOD ELEMENTARY	TEACHER-GRADE 3	08/14/2025
TOPP, MORGAN C	BLUE RIVER ELEMENTARY	TEACHER-GRADE 1	08/15/2025



Human Resources Report to the Board of Education

September 8, 2025

Administration recommends approval of the following actions:

RESIGNATIONS

<u>Name</u>	<u>Location</u>	<u>Position</u>	<u>Effective</u>
SUAREZ, JEANNETTE REYNA	LEAWOOD ELEMENTARY	TEACHER-SPANISH	05/22/2026
ZALMAN, SKYLER M	COTTONWOOD POINT ELEMENTARY	SPEECH LANGUAGE PATHOLOGIST	09/03/2025
ZALMAN, SKYLER M	HEARTLAND ELEMENTARY	SPEECH LANGUAGE PATHOLOGIST	09/03/2025



Human Resources Report to the Board of Education

Addendum

September 8, 2025

Administration recommends approval of the following actions:

SUPPLEMENTALS

<u>Name</u>	<u>Location</u>	<u>Position</u>	<u>Effective</u>
ADAMS, BLAKE	BLUE VALLEY NORTHWEST HS	ASST DIRECTOR-FALL MUSICAL	08/16/2025
AITKEN, SARA HEESZEL	HEARTLAND ELEMENTARY	8 EXTENDED DAYS-LIBR MEDIA SPC	08/06/2025
AITKEN, SARA HEESZEL	DISTRICT WIDE	PDC REPRESENTATIVE	08/06/2025
ALBERTIN, KAREN SUE	HARMONY MIDDLE SCHOOL	LEADERSHIP TEAM MEMBER	08/06/2025
ALDERMAN, AMY MICHELLE	LAKEWOOD MIDDLE SCHOOL	LEADERSHIP TEAM MEMBER	08/06/2025
ALEXANDER, CARISSA N	VIRTUAL ED	VIRTUAL EDUCATION-FALL	08/06/2025
ALEXANDER, KELLEY RENE	MORSE ELEMENTARY	8 EXTENDED DAYS-LIBR MEDIA SPC	08/06/2025
ALLEN, BRIDGET ELAINE	BLUE VALLEY WEST HIGH SCHOOL	12 EXTENDED DAYS-DEPT CHAIR	08/06/2025
ALLEN, CLAIRE A	LAKEWOOD MIDDLE SCHOOL	17 EXTENDED DAYS-COUNSELOR	08/06/2025
ALLEN, CLAIRE A	LAKEWOOD MIDDLE SCHOOL	LEADERSHIP TEAM MEMBER	08/06/2025
ALLISON, JOSEPH B	LAKEWOOD MIDDLE SCHOOL	HEAD COACH-WRESTLING BOYS	11/16/2025
ALLISON, JOSEPH B	LAKEWOOD MIDDLE SCHOOL	HEAD COACH-WRESTLING GIRLS	11/16/2025
AMIHERE, CHRISTINE LOUISE	AUBRY BEND MIDDLE SCHOOL	ASST DIRECTOR-FALL MUSICAL	08/16/2025
AMMERMAN, ERIC D	OVERLAND TRAIL MIDDLE SCHOOL	ASST DIRECTOR-FALL MUSICAL	08/16/2025
AMMERMAN, ERIC D	OVERLAND TRAIL MIDDLE SCHOOL	LEADERSHIP TEAM MEMBER	08/06/2025
ANDERSON, AARON H	BLUE VALLEY WEST HIGH SCHOOL	SUPERVISOR-GYMNASIUM	11/16/2025
ANDERSON, DONNA M	MISSION TRAIL ELEMENTARY	2 EXTENDED DAYS-NURSE ES	08/06/2025
ANDREWS, JAMES NICHOLAS	SUNRISE POINT ELEMENTARY	DIRECTOR-CHOIR	08/06/2025
ANDREWS, JAMES NICHOLAS	SUNRISE POINT ELEMENTARY	DIRECTOR-VOCAL MUSIC	08/06/2025
ARBUCCI, MICHAEL	HARMONY MIDDLE SCHOOL	DIRECTOR-ENRICHMENT ORCHESTRA	08/06/2025
ARBUCCI, MICHAEL	HARMONY ELEMENTARY	DIRECTOR-INSTRUMENTAL MUSIC	08/06/2025
ARNDT, MEGAN ELIZABETH	BLUE VALLEY NORTH HIGH SCHOOL	ASST COACH-SOFTBALL	03/01/2026
ARNOLD-COLEMAN, JENNIFER A	OVERLAND TRAIL ELEMENTARY	2 EXTENDED DAYS-NURSE ES	08/06/2025
ASQUITH, ROBERT WILLIAM	VIRTUAL ED	42 EXTENDED DAYS-VIRTUAL ED	08/06/2025
AUBREY, PAUL STANLEY	PRAIRIE STAR MIDDLE SCHOOL	LEADERSHIP TEAM MEMBER	08/06/2025
BABB, CRYSTAL G	DISTRICT WIDE	LIMITED SUPPLY 1 OF 3	09/16/2025
BABB, CRYSTAL G	BLUE VALLEY NORTHWEST HS	SUPERVISOR-GYMNASIUM	11/16/2025
BABKIN, SARAH ELIZABETH	OXFORD MIDDLE SCHOOL	HEAD SPONSOR-CHEERLEADING	08/06/2025
BAKER, KATHLEEN ELIZABETH	LAKEWOOD ELEMENTARY	2 EXTENDED DAYS-NURSE ES	08/06/2025
BAKER, NALAINA MICHELLE	SERVICE CENTER	17 EXTENDED DAYS-PSYCHOLOGIST	08/06/2025
BAKER, NALAINA MICHELLE	BLUE VALLEY ACADEMY	17 EXTENDED DAYS-PSYCHOLOGIST	08/06/2025
BAKER, WILLIAM FRANK	LAKEWOOD MIDDLE SCHOOL	LEADERSHIP TEAM MEMBER	08/06/2025
BALL, JULIE D	SUNSET RIDGE ELEMENTARY	9 EXTENDED DAYS-COUNSELOR	08/06/2025
BANKS, ANGELA LAUREN	STANLEY ELEMENTARY	DIRECTOR-CHOIR	08/06/2025
BANKS, ANGELA LAUREN	STANLEY ELEMENTARY	DIRECTOR-VOCAL MUSIC	08/06/2025
BANKS, THORNE BISBEE	DISTRICT WIDE	LIMITED SUPPLY 1 OF 3	09/16/2025
BANKS, THORNE BISBEE	BLUE VALLEY SOUTHWEST HS	SPONSOR-NATL CURRIC HONOR SOC	08/06/2025
BARANOWSKI, KERRI MARIE	STILWELL ELEMENTARY	2 EXTENDED DAYS-NURSE ES	08/06/2025
BARKLEY, JORDAN SARA	LAKEWOOD MIDDLE SCHOOL	LEADERSHIP TEAM MEMBER	08/06/2025
BARLOWS, JENNIFER LYNN	BLUE RIVER ELEMENTARY	2 EXTENDED DAYS-NURSE ES	08/06/2025



Human Resources Report to the Board of Education

Addendum

September 8, 2025

Administration recommends approval of the following actions:

BARNES, DUSTIN LYNN	BLUE VALLEY SOUTHWEST HS	SUPERVISOR-GYMNASIUM	11/16/2025
BARNES, TARA MICHEL	PRAIRIE STAR MIDDLE SCHOOL	LEADERSHIP TEAM MEMBER	08/06/2025
BASOM, AMBER NICHOLE	HEARTLAND ELEMENTARY	9 EXTENDED DAYS-COUNSELOR	08/06/2025
BATT, NICOLE ELIZABETH	DISTRICT WIDE	LIMITED SUPPLY 1 OF 3	09/16/2025
BAUCOM, KELLI E	BLUE VALLEY SOUTHWEST HS	17 EXTENDED DAYS-COUNSELOR	08/06/2025
BAUMGARNER, JESSICA DIANE	OVERLAND TRAIL ELEMENTARY	DIRECTOR-CHOIR	08/06/2025
BAUMGARNER, JESSICA DIANE	OVERLAND TRAIL ELEMENTARY	DIRECTOR-VOCAL MUSIC	08/06/2025
BEECHER, JOSEPH WARREN	BLUE VALLEY SOUTHWEST HS	ASST COACH-BOYS SOCCER	08/16/2025
BELCHER, BROOKE LEIGH	DISTRICT WIDE	PDC REPRESENTATIVE	08/06/2025
BELL, JANA E A	MORSE ELEMENTARY	2 EXTENDED DAYS-NURSE ES	08/06/2025
BENSCHIEDT, LAURA LOUISE	CENTER FOR ADV PROF STUDIES	8 EXTENDED DAYS-STRAND LEADER	08/06/2025
BERAK, COLETT PEARL	HILLTOP LEARNING CENTER	10 EXTENDED DAYS-SS CONSULTANT	08/06/2025
BEREN, SARAH ZAVETT	EDUCATIONAL SUPPORT CENTER	17 EXTENDED DAYS-CAREER READY	08/06/2025
BERGEE, JILL A	VALLEY PARK ELEMENTARY	16 EXTENDED DAYS-IDC	08/06/2025
BERGEE, JILL A	DISTRICT WIDE	PDC REPRESENTATIVE	08/06/2025
BERTHOLD, DUSTIN A	BLUE VALLEY MIDDLE SCHOOL	LEADERSHIP TEAM MEMBER	08/06/2025
BIEN, ADAM RICHARD	VIRTUAL ED	VIRTUAL EDUCATION-FALL	08/06/2025
BILLQUIST, LINDSAY ELIZABETH	LEAWOOD MIDDLE SCHOOL	17 EXTENDED DAYS-COUNSELOR	08/06/2025
BILLQUIST, LINDSAY ELIZABETH	LEAWOOD MIDDLE SCHOOL	ASST DIRECTOR-FALL MUSICAL	08/16/2025
BIRD, ABIGAIL CATHERINE	BLUE VALLEY NORTHWEST HS	ASST COACH-GIRLS BASKETBALL	11/16/2025
BLACK, PAULA JEAN	LAKWOOD MIDDLE SCHOOL	LEADERSHIP TEAM MEMBER	08/06/2025
BLACKBURN, BRENDON GREER	DISTRICT WIDE	LIMITED SUPPLY 1 OF 3	09/16/2025
BLACKWELL, SHELLEY L	LEAWOOD ELEMENTARY	16 EXTENDED DAYS-ADMIN INTERN	08/06/2025
BLISS, DANIELLE LAUREN	DISTRICT WIDE	PDC REPRESENTATIVE	08/06/2025
BLUNT, ALLISON ELAINE	AUBRY BEND MIDDLE SCHOOL	17 EXTENDED DAYS-COUNSELOR	08/06/2025
BOHL, KELSEY MARIE	OAK HILL ELEMENTARY	9 EXTENDED DAYS-COUNSELOR	08/06/2025
BOLDRIDGE, CLAUDINE ELIZABETH	BLUE VALLEY NORTHWEST HS	17 EXTENDED DAYS-PSYCHOLOGIST	08/06/2025
BOLLINGER, BRIAN ROBERT	HARMONY MIDDLE SCHOOL	MS COORDINATOR-INTERVENTION	08/06/2025
BOLTON, CRISTY YVONNE	EDUCATIONAL SUPPORT CENTER	24 EXTENDED DAYS-DCT	08/06/2025
BOLTZ, KAYLA ANN	BLUE VALLEY MIDDLE SCHOOL	17 EXTENDED DAYS-COUNSELOR	08/06/2025
BOMAN, REBECCA ANNE	DISTRICT WIDE	PDC REPRESENTATIVE	08/06/2025
BOOK, ANDREW JOHN	BLUE VALLEY WEST HIGH SCHOOL	ASST DIRECTOR-WINTER MUSICAL	11/16/2025
BOOK, ANDREW JOHN	CEDAR HILLS ELEMENTARY	DIRECTOR-INSTRUMENTAL MUSIC	08/06/2025
BOOTON, MARY MARGARET	HILLTOP LEARNING CENTER	17 EXTENDED DAYS-PSYCHOLOGIST	08/06/2025
BOWLIN, KRISTAN ANN	BLUE VALLEY SOUTHWEST HS	8 EXTENDED DAYS-LIBR MEDIA SPC	08/06/2025
BOWMAN, ALEXIS MARY	DISTRICT WIDE	LIMITED SUPPLY 1 OF 3	09/16/2025
BOX, BRIAN SAMUEL	BLUE VALLEY NORTH HIGH SCHOOL	8 EXTENDED DAYS-DEPT CHAIR	08/06/2025
BRAAK, DEREK JEFFREY	BLUE VALLEY NORTH HIGH SCHOOL	ASST COACH-BOYS SOCCER	08/16/2025
BRACKMAN, EMILY MICHELLE	DISTRICT WIDE	LIMITED SUPPLY 1 OF 3	09/16/2025
BRADEN, KENNETH R	BLUE VALLEY SOUTHWEST HS	ASST COACH-FOOTBALL	08/16/2025
BREEDLOVE, JEFFREY MICHAEL	BLUE VALLEY NORTH HIGH SCHOOL	12 EXTENDED DAYS-DEPT CHAIR	08/06/2025
BRIGGS, DAVID A	BLUE VALLEY HIGH SCHOOL	8 EXTENDED DAYS-DEPT CHAIR	08/06/2025
BRIODY, JILL M	BLUE VALLEY NORTHWEST HS	17 EXTENDED DAYS-PSYCHOLOGIST	08/06/2025
BRIODY, JILL M	LEAWOOD ELEMENTARY	17 EXTENDED DAYS-PSYCHOLOGIST	08/06/2025



Human Resources Report to the Board of Education

Addendum

September 8, 2025

Administration recommends approval of the following actions:

BRITE, KATHRYN MAUREEN	DISTRICT WIDE	LIMITED SUPPLY 1 OF 3	09/16/2025
BROWN, AMY JO	BLUE VALLEY WEST HIGH SCHOOL	17 EXTENDED DAYS-COUNSELOR	08/06/2025
BROWN, AMY JO	BLUE VALLEY WEST HIGH SCHOOL	6 EXTENDED DAYS-DEPT CHAIR	08/06/2025
BROWN, PAUL B	BLUE VALLEY HIGH SCHOOL	3 EXTENDED DAYS-DEPT CHAIR	08/06/2025
BROWN, SARAH DOLENCE	BLUE VALLEY SOUTHWEST HS	12 EXTENDED DAYS-DEPT CHAIR	08/06/2025
BROWNLIE, BRIDGETT MICHELE	BLUE VALLEY NORTH HIGH SCHOOL	17 EXTENDED DAYS-COUNSELOR	08/06/2025
BRUMMER, DARCY LYNN	PRAIRIE STAR MIDDLE SCHOOL	ASST DIRECTOR-FALL PLAY	08/16/2025
BRUNER-LASISTER, HARMONY SAFFRON	WOLF SPRINGS ELEMENTARY	8 EXTENDED DAYS-LIBR MEDIA SPC	08/06/2025
BUEHLER, JENNIFER ALICIA	BLUE VALLEY WEST HIGH SCHOOL	12 EXTENDED DAYS-DEPT CHAIR	08/06/2025
BUFFINGTON, COURTNEY KRISTIN	VIRTUAL ED	VIRTUAL EDUCATION-FALL	08/06/2025
BULLOCK, LEWIS HENRY	TIMBER CREEK ELEMENTARY	DIRECTOR-INSTRUMENTAL MUSIC	08/06/2025
BULLOCK, LEWIS HENRY	AUBRY BEND MIDDLE SCHOOL	DIRECTOR-ORCHESTRA	08/06/2025
BUSER, ABIGAIL ELIZABETH	HARMONY ELEMENTARY	8 EXTENDED DAYS-LIBR MEDIA SPC	08/06/2025
BUSHOUSE, KELLY ANNE	BLUE VALLEY WEST HIGH SCHOOL	ASST DIRECTOR-MARCHING BAND	08/16/2025
BUSHOUSE, KELLY ANNE	LAKEWOOD MIDDLE SCHOOL	DIRECTOR-BAND	08/06/2025
BUSHOUSE, KELLY ANNE	LAKEWOOD MIDDLE SCHOOL	DIRECTOR-JAZZ BAND	08/06/2025
BUXTON, ASHLEY MARIE	BLUE VALLEY HIGH SCHOOL	20 EXTENDED DAYS-ADMIN INTERN	08/06/2025
BUXTON, ASHLEY MARIE	BLUE VALLEY HIGH SCHOOL	AD INTERN SUPERVISION DUTIES	08/06/2025
BYRNE, JULIE ANN	PRAIRIE STAR ELEMENTARY	DIRECTOR-CHOIR	08/06/2025
BYRNE, JULIE ANN	PRAIRIE STAR ELEMENTARY	DIRECTOR-VOCAL MUSIC	08/06/2025
CAIN, SHERI DAWN	PRAIRIE STAR MIDDLE SCHOOL	DIRECTOR-ENRICHMENT ORCHESTRA	08/06/2025
CAIN, SHERI DAWN	PRAIRIE STAR ELEMENTARY	DIRECTOR-INSTRUMENTAL MUSIC	08/06/2025
CALLAND, KRISTIN LEIGH	BLUE VALLEY MIDDLE SCHOOL	16 EXTENDED DAYS-IDC	08/06/2025
CALLAND, KRISTIN LEIGH	PLEASANT RIDGE MIDDLE SCHOOL	16 EXTENDED DAYS-IDC	08/06/2025
CALLAND, KRISTIN LEIGH	BLUE VALLEY MIDDLE SCHOOL	LEADERSHIP TEAM MEMBER	08/06/2025
CALLAND, KRISTIN LEIGH	PLEASANT RIDGE MIDDLE SCHOOL	LEADERSHIP TEAM MEMBER	08/06/2025
CAMPBELL, JESSICA LYNNE	DISTRICT WIDE	LIMITED SUPPLY 1 OF 3	09/16/2025
CARENAS, SONIA MARIA	BLUE VALLEY NORTH HIGH SCHOOL	8 EXTENDED DAYS-DEPT CHAIR	08/06/2025
CAREY, SOPHIA NICOLE	COTTONWOOD POINT ELEMENTARY	DIRECTOR-CHOIR	08/06/2025
CAREY, SOPHIA NICOLE	COTTONWOOD POINT ELEMENTARY	DIRECTOR-VOCAL MUSIC	08/06/2025
CARPENTER, TERI RENEE	LAKEWOOD MIDDLE SCHOOL	4 EXTENDED DAYS-NURSE MS	08/06/2025
CATANZARO, DANIEL M	BLUE VALLEY WEST HIGH SCHOOL	COORDINATOR-FOOTBALL	08/16/2025
CATES, AMANDA GAYLE	LIBERTY VIEW ELEMENTARY	9 EXTENDED DAYS-COUNSELOR	08/06/2025
CHADWELL, MELLANY LEIGH	LEAWOOD MIDDLE SCHOOL	LEADERSHIP TEAM MEMBER	08/06/2025
CHADWELL, MELLANY LEIGH	LEAWOOD MIDDLE SCHOOL	SPONSOR-DRILL/DANCE TEAM	08/06/2025
CHAPMAN, LAUREN ANNE	PRAIRIE STAR ELEMENTARY	9 EXTENDED DAYS-COUNSELOR	08/06/2025
CHERIAN, THOMAS B	LAKEWOOD ELEMENTARY	9 EXTENDED DAYS-COUNSELOR	08/06/2025
CHRISTENSEN, MATTHEW CARY	BLUE VALLEY SOUTHWEST HS	12 EXTENDED DAYS-DEPT CHAIR	08/06/2025
CHRISTENSEN, MATTHEW CARY	VIRTUAL ED	VIRTUAL EDUCATION-FALL	08/06/2025
CHURCHILL, KELLY ELIZABETH	ASPEN GROVE ELEMENTARY	16 EXTENDED DAYS-IDC	08/06/2025
CHURCHILL, KELLY ELIZABETH	STANLEY ELEMENTARY	16 EXTENDED DAYS-IDC	08/06/2025
CHUSHUK, RACHEL SUZANNE	BLUE VALLEY SOUTHWEST HS	4 EXTENDED DAYS-DEPT CHAIR	08/06/2025
CHUSHUK, RACHEL SUZANNE	BLUE VALLEY SOUTHWEST HS	8 EXTENDED DAYS-TECH INTEG SPC	08/06/2025
CLARK, MELISSA RENEE	EDUCATIONAL SUPPORT CENTER	24 EXTENDED DAYS-DCT	08/06/2025



Human Resources Report to the Board of Education

Addendum

September 8, 2025

Administration recommends approval of the following actions:

CLARK, MISTY JEAN	PLEASANT RIDGE MIDDLE SCHOOL	ASST COACH-VOLLEYBALL	08/16/2025
CLAUSEN, MELODY J	BLUE VALLEY SOUTHWEST HS	12 EXTENDED DAYS-DEPT CHAIR	08/06/2025
CLAUSEN, MELODY J	BLUE VALLEY SOUTHWEST HS	HEAD SPONSOR-SCIENCE OLYMPIAD	08/06/2025
CLEMENTS, JENNIFER JO W	DISTRICT WIDE	PDC REPRESENTATIVE	08/06/2025
CLOUD, BRITTANY SUMMER	VALLEY PARK ELEMENTARY	9 EXTENDED DAYS-COUNSELOR	08/06/2025
CODAY, AMANDA M	HEARTLAND ELEMENTARY	DIRECTOR-CHOIR	08/06/2025
CODAY, AMANDA M	HEARTLAND ELEMENTARY	DIRECTOR-VOCAL MUSIC	08/06/2025
COHN, KATIE ELIZABETH	STANLEY ELEMENTARY	9 EXTENDED DAYS-COUNSELOR	08/06/2025
COLLIER, JENNIFER RENE	COTTONWOOD POINT ELEMENTARY	2 EXTENDED DAYS-NURSE ES	08/06/2025
COLLINS, CAMERON SLADE	OXFORD MIDDLE SCHOOL	LEADERSHIP TEAM MEMBER	08/06/2025
CONRAD, LAUREL MARIE	HILLTOP LEARNING CENTER	10 EXTENDED DAYS-SS CONSULTANT	08/06/2025
CONRAD, MACEY DAWN	DISTRICT WIDE	LIMITED SUPPLY 1 OF 1	09/16/2025
CONRAD-BOWERSOX, PIPER MICHELE	OXFORD MIDDLE SCHOOL	4 EXTENDED DAYS-NURSE MS	08/06/2025
CONTRUCCI, RAMI J	DISTRICT WIDE	PDC REPRESENTATIVE	08/06/2025
COOK, LORI MARIE	HARMONY MIDDLE SCHOOL	17 EXTENDED DAYS-COUNSELOR	08/06/2025
COOK, TIMOTHY RYAN	BLUE VALLEY WEST HIGH SCHOOL	SUPERVISOR-GYMNASIUM	11/16/2025
COOPER, ALISON BESSETTE	OXFORD MIDDLE SCHOOL	17 EXTENDED DAYS-COUNSELOR	08/06/2025
COPELAND, AVERY DOVE	DISTRICT WIDE	LIMITED SUPPLY 1 OF 3	09/16/2025
COPELAND, ELIZABETH NASH	MISSION TRAIL ELEMENTARY	DIRECTOR-INSTRUMENTAL MUSIC	08/06/2025
COPELAND, ELIZABETH NASH	LEAWOOD ELEMENTARY	DIRECTOR-INSTRUMENTAL MUSIC	08/06/2025
COPELAND, KATRINE METTE	STILWELL ELEMENTARY	9 EXTENDED DAYS-COUNSELOR	08/06/2025
COPELAND, SAMUEL LEON	HEARTLAND ELEMENTARY	DIRECTOR-INSTRUMENTAL MUSIC	08/06/2025
CORNELIUS, ABIGAIL M	BLUE VALLEY NORTH HIGH SCHOOL	4 EXTENDED DAYS-DEPT CHAIR	08/06/2025
CORNELIUS, ABIGAIL M	BLUE VALLEY NORTH HIGH SCHOOL	8 EXTENDED DAYS-LIBR MEDIA SPC	08/06/2025
CORWINE, SHELBY NICOLE	PLEASANT RIDGE MIDDLE SCHOOL	ASST DIRECTOR-FALL PLAY	08/16/2025
CRANE, ABIGAIL DIANE	EDUCATIONAL SUPPORT CENTER	16 EXTENDED DAYS-IDC	08/06/2025
CRANE, ABIGAIL DIANE	AUBRY BEND MIDDLE SCHOOL	LEADERSHIP TEAM MEMBER	08/06/2025
CROUCH, LAUREN ELIZABETH	BLUE VALLEY NORTHWEST HS	17 EXTENDED DAYS-COUNSELOR	08/06/2025
CUMBERLAND IV, EDWIN EUGENE	BLUE VALLEY NORTHWEST HS	SPONSOR-11TH GRADE	08/06/2025
DAHM, ELISE MARIE	BLUE VALLEY SOUTHWEST HS	HEAD SPONSOR-COLOR GUARD	08/20/2025
DAIGLE, JOHN PAUL	BLUE VALLEY NORTH HIGH SCHOOL	8 EXTENDED DAYS-DEPT CHAIR	08/06/2025
DALTON, REBECCA A	DISTRICT WIDE	PDC REPRESENTATIVE	08/06/2025
DARK, ANN C	BLUE VALLEY WEST HIGH SCHOOL	11 EXTENDED DAYS-DEPT CHAIR	08/06/2025
DARK, ANN C	VIRTUAL ED	VIRTUAL EDUCATION-FALL	08/06/2025
DAVIS, JANET MARIE	DISTRICT WIDE	PDC REPRESENTATIVE	08/06/2025
DAWSON, CHRISTINE MARIE	HARMONY MIDDLE SCHOOL	LEADERSHIP TEAM MEMBER	08/06/2025
DAWSON, CHRISTINE MARIE	DISTRICT WIDE	PDC REPRESENTATIVE	08/06/2025
DE LEIRIS, SARAH CATHERINE	INDIAN VALLEY ELEMENTARY	DIRECTOR-INSTRUMENTAL MUSIC	08/06/2025
DE LEIRIS, SARAH CATHERINE	COTTONWOOD POINT ELEMENTARY	DIRECTOR-INSTRUMENTAL MUSIC	08/06/2025
DEARTH, JACQUELINE MARIE	EDUCATIONAL SUPPORT CENTER	16 EXTENDED DAYS-DCT	08/06/2025
DELUCA, KRISTINA MARIE	ASPEN GROVE ELEMENTARY	8 EXTENDED DAYS-LIBR MEDIA SPC	08/06/2025
DENGES, AUDREY RENE	BLUE VALLEY HIGH SCHOOL	HEAD SPONSOR-HOSA	08/06/2025
DEWITT, KIMBERLY	WOLF SPRINGS ELEMENTARY	DIRECTOR-CHOIR	08/06/2025
DEWITT, KIMBERLY	WOLF SPRINGS ELEMENTARY	DIRECTOR-VOCAL MUSIC	08/06/2025



Human Resources Report to the Board of Education

Addendum

September 8, 2025

Administration recommends approval of the following actions:

DICKERSON, STACEY E	PLEASANT RIDGE MIDDLE SCHOOL	LEADERSHIP TEAM MEMBER	08/06/2025
DICKERSON, STACEY E	PLEASANT RIDGE MIDDLE SCHOOL	TEAM LEADER-GRADE 6	08/06/2025
DILLAVOU, MEGAN SUZANNE	HILLTOP LEARNING CENTER	10 EXTENDED DAYS-SS CONSULTANT	08/06/2025
DILLAVOU, MEGAN SUZANNE	DISTRICT WIDE	PDC REPRESENTATIVE	08/06/2025
DIXON, KRISTI L	BLUE VALLEY SOUTHWEST HS	17 EXTENDED DAYS-COUNSELOR	08/06/2025
DIXON, KRISTI L	DISTRICT WIDE	PDC REPRESENTATIVE	08/06/2025
DOCKENDORF, SARAH ANN	BLUE VALLEY NORTH HIGH SCHOOL	17 EXTENDED DAYS-PSYCHOLOGIST	08/06/2025
DOLLINS, SARAH RENEE	BLUE VALLEY HIGH SCHOOL	ASST DIRECTOR-FALL MUSICAL	08/16/2025
DONNELLY-VAZQUEZ, CATALINA NAOMI	BLUE VALLEY NORTH HIGH SCHOOL	17 EXTENDED DAYS-COUNSELOR	08/06/2025
DONOGHUE, BRIANNA E	SUNSET RIDGE ELEMENTARY	2 EXTENDED DAYS-NURSE ES	08/06/2025
DREYER, MIKAYLA WEBER	HILLTOP LEARNING CENTER	10 EXTENDED DAYS-SS CONSULTANT	08/06/2025
DRUTEN, EDIE ANN	LEAWOOD ELEMENTARY	9 EXTENDED DAYS-COUNSELOR	08/06/2025
DUGAN, JENNIFER GILL	DISTRICT WIDE	PDC REPRESENTATIVE	08/06/2025
DUMMITT, ANNE MARIE	LAKEWOOD MIDDLE SCHOOL	17 EXTENDED DAYS-COUNSELOR	08/06/2025
DUNN, ANNA LEIGH	BLUE VALLEY WEST HIGH SCHOOL	11 EXTENDED DAYS-DEPT CHAIR	08/06/2025
DURHAM, TANYA LYNN	BLUE VALLEY SOUTHWEST HS	ASST COACH-VOLLEYBALL	08/16/2025
ECKERT, SARAH N	BLUE VALLEY MIDDLE SCHOOL	8 EXTENDED DAYS-LIBR MEDIA SPC	08/06/2025
ECKERT, SARAH N	BLUE VALLEY MIDDLE SCHOOL	ASST DIRECTOR-FALL PLAY	08/16/2025
ECKERT, SARAH N	DISTRICT WIDE	PDC REPRESENTATIVE	08/06/2025
EHLERS, KAREN LAURA	PRAIRIE STAR ELEMENTARY	2 EXTENDED DAYS-NURSE ES	08/06/2025
EKSTRAND, KORENE KAYE	LAKEWOOD MIDDLE SCHOOL	8 EXTENDED DAYS-LIBR MEDIA SPC	08/06/2025
EKSTRAND, KORENE KAYE	DISTRICT WIDE	PDC REPRESENTATIVE	08/06/2025
ENGEL, CASEY KATHLEEN	BLUE VALLEY HIGH SCHOOL	12 EXTENDED DAYS-DEPT CHAIR	08/06/2025
ERBACHER, STEVEN ELVIS	DISTRICT WIDE	LIMITED SUPPLY 1 OF 3	09/16/2025
ERKER, LAUREN E	OXFORD MIDDLE SCHOOL	LEADERSHIP TEAM MEMBER	08/06/2025
ERNST, SANDY LEE	DISTRICT WIDE	PDC REPRESENTATIVE	08/06/2025
ERPELDING, JUDY ELLEN	VALLEY PARK ELEMENTARY	DIRECTOR-INSTRUMENTAL MUSIC	08/06/2025
ERPELDING, JUDY ELLEN	OVERLAND TRAIL ELEMENTARY	DIRECTOR-INSTRUMENTAL MUSIC	08/06/2025
FALCO, ADRIANE LEA	BLUE VALLEY MIDDLE SCHOOL	LEADERSHIP TEAM MEMBER	08/06/2025
FAY, LAURA JOHANSON	COTTONWOOD POINT ELEMENTARY	9 EXTENDED DAYS-COUNSELOR	08/06/2025
FAZIO, MICHELLE LYNNE	TIMBER CREEK ELEMENTARY	9 EXTENDED DAYS-COUNSELOR	08/06/2025
FEAR, AMY ELISSA	STANLEY ELEMENTARY	DIRECTOR-INSTRUMENTAL MUSIC	08/06/2025
FEAR, AMY ELISSA	STILWELL ELEMENTARY	DIRECTOR-INSTRUMENTAL MUSIC	08/06/2025
FEE, ELISE ROCK	LAKEWOOD ELEMENTARY	8 EXTENDED DAYS-LIBR MEDIA SPC	08/06/2025
FELDMANN, ERIN LYNN	BLUE RIVER ELEMENTARY	8 EXTENDED DAYS-LIBR MEDIA SPC	08/06/2025
FELKE BOWDEN, CAREY ANNE	CEDAR HILLS ELEMENTARY	DIRECTOR-VOCAL MUSIC	08/06/2025
FERGUSON, ASHLEY STEELE	STANLEY ELEMENTARY	2 EXTENDED DAYS-NURSE ES	08/06/2025
FERNANDEZ, VANESSA MARIA	OVERLAND TRAIL MIDDLE SCHOOL	8 EXTENDED DAYS-LIBR MEDIA SPC	08/06/2025
FEUERBORN, TEGAN M	CEDAR HILLS ELEMENTARY	2 EXTENDED DAYS-NURSE ES	08/06/2025
FISH, EMILY SUE	LEAWOOD ELEMENTARY	DIRECTOR-CHOIR	08/06/2025
FISH, EMILY SUE	LEAWOOD ELEMENTARY	DIRECTOR-VOCAL MUSIC	08/06/2025
FONTAINE, AMY E	OXFORD MIDDLE SCHOOL	SPONSOR-DRILL/DANCE TEAM	08/06/2025
FORD, JENNIFER LYNN	DISTRICT WIDE	PDC REPRESENTATIVE	08/06/2025
FORNELLI, RYLIE MICHELE	BLUE VALLEY SOUTHWEST HS	8 EXTENDED DAYS-DEPT CHAIR	08/06/2025



Human Resources Report to the Board of Education

Addendum

September 8, 2025

Administration recommends approval of the following actions:

FRANSEN, JENNIFER ANN	DISTRICT WIDE	PDC REPRESENTATIVE	08/06/2025
FREEMAN, CHRISTINE MARIE	AUBRY BEND MIDDLE SCHOOL	LEADERSHIP TEAM MEMBER	08/06/2025
FREEMAN, CHRISTINE MARIE	DISTRICT WIDE	PDC REPRESENTATIVE	08/06/2025
FREESTONE, JENNIFER LYNNE	BLUE VALLEY ACADEMY	17 EXTENDED DAYS-COUNSELOR	08/06/2025
FRITZ, ANN M	BLUE VALLEY NORTH HIGH SCHOOL	3 EXTENDED DAYS-DEPT CHAIR	08/06/2025
FRYE, CHRISTOPHER V	BLUE VALLEY WEST HIGH SCHOOL	ASST DIRECTOR-FALL PLAY	08/16/2025
FRYE, CHRISTOPHER V	BLUE VALLEY WEST HIGH SCHOOL	ASST DIRECTOR-SPRING PLAY	03/01/2026
FRYE, CHRISTOPHER V	BLUE VALLEY WEST HIGH SCHOOL	ASST DIRECTOR-WINTER MUSICAL	11/16/2025
GABEL, AMY ELIZABETH	PRAIRIE STAR MIDDLE SCHOOL	MS COORDINATOR-SCIENCE	08/06/2025
GABEL, KATE ROSE	DISTRICT WIDE	LIMITED SUPPLY 1 OF 3	09/16/2025
GAGE, BRAYDEN THOMAS	DISTRICT WIDE	LIMITED SUPPLY 1 OF 3	09/16/2025
GAGNON, JODI LYNNE	HILLTOP LEARNING CENTER	17 EXTENDED DAYS-PSYCHOLOGIST	08/06/2025
GAMBLE, LINDSAY ELIZABETH	PLEASANT RIDGE MIDDLE SCHOOL	LEADERSHIP TEAM MEMBER	08/06/2025
GAMBLE, LINDSAY ELIZABETH	PLEASANT RIDGE MIDDLE SCHOOL	TEAM LEAD-EXPLORATION	08/06/2025
GAPSCH, CAITLIN ELIZABETH	VALLEY PARK ELEMENTARY	8 EXTENDED DAYS-LIBR MEDIA SPC	08/06/2025
GARCIA, KYLIE RENEE	BLUE VALLEY HIGH SCHOOL	8 EXTENDED DAYS-DEPT CHAIR	08/06/2025
GARDNER, CHARLES GUY	BLUE VALLEY WEST HIGH SCHOOL	ASST DIRECTOR-FALL PLAY	08/16/2025
GARDNER, CHARLES GUY	BLUE VALLEY WEST HIGH SCHOOL	ASST DIRECTOR-SPRING PLAY	03/01/2026
GARDNER, CHARLES GUY	BLUE VALLEY WEST HIGH SCHOOL	ASST DIRECTOR-WINTER MUSICAL	11/16/2025
GARRETSON, MARY FRANCES	DISTRICT WIDE	PDC REPRESENTATIVE	08/06/2025
GARVER, ASHLEY T	VIRTUAL ED	VIRTUAL EDUCATION-FALL	08/06/2025
GEIST, JOSEPH R	BLUE VALLEY WEST HIGH SCHOOL	5 EXTENDED DAYS-TECH INTEG SPC	08/06/2025
GEIST, JOSEPH R	BLUE VALLEY WEST HIGH SCHOOL	8 EXTENDED DAYS-LIBR MEDIA SPC	08/06/2025
GEIST, KATHERINE ELAINE	LEAWOOD ELEMENTARY	8 EXTENDED DAYS-LIBR MEDIA SPC	08/06/2025
GERBRANDT, MEGAN ELIZABETH	BLUE RIVER ELEMENTARY	DIRECTOR-INSTRUMENTAL MUSIC	08/06/2025
GIBBS, DUSTIN COLE	DISTRICT WIDE	LIMITED SUPPLY 1 OF 3	09/16/2025
GIBSON, ANN MARIE	HARMONY MIDDLE SCHOOL	16 EXTENDED DAYS-IDC	08/06/2025
GIBSON, ANN MARIE	LAKWOOD MIDDLE SCHOOL	16 EXTENDED DAYS-IDC	08/06/2025
GIBSON, ANN MARIE	HARMONY MIDDLE SCHOOL	LEADERSHIP TEAM MEMBER	08/06/2025
GIBSON, ANN MARIE	LAKWOOD MIDDLE SCHOOL	LEADERSHIP TEAM MEMBER	08/06/2025
GIULIANI, GABRIELLA N	SUNSET RIDGE ELEMENTARY	DIRECTOR-CHOIR	08/06/2025
GIULIANI, GABRIELLA N	SUNSET RIDGE ELEMENTARY	DIRECTOR-VOCAL MUSIC	08/06/2025
GLASS, BRANDY D	AUBRY BEND MIDDLE SCHOOL	4 EXTENDED DAYS-NURSE MS	08/06/2025
GLOTZBACH, MARY CHRISTINE	BLUE VALLEY HIGH SCHOOL	17 EXTENDED DAYS-COUNSELOR	08/06/2025
GOLDSMITH, KIMBERLY LYNN	BLUE VALLEY NORTHWEST HS	17 EXTENDED DAYS-COUNSELOR	08/06/2025
GOODWIN, STEPHANIE LYNN	BLUE VALLEY MIDDLE SCHOOL	4 EXTENDED DAYS-NURSE MS	08/06/2025
GORMLEY, ALEXIS NICOLE	SUNSET RIDGE ELEMENTARY	17 EXTENDED DAYS-PSYCHOLOGIST	08/06/2025
GORMLEY, ALEXIS NICOLE	LAKWOOD ELEMENTARY	17 EXTENDED DAYS-PSYCHOLOGIST	08/06/2025
GOUGER, JILL MARIE	OXFORD MIDDLE SCHOOL	17 EXTENDED DAYS-COUNSELOR	08/06/2025
GOUGER, JILL MARIE	OXFORD MIDDLE SCHOOL	LEADERSHIP TEAM MEMBER	08/06/2025
GRIFFITH, AUBREY RUTH	BLUE VALLEY HIGH SCHOOL	ASST COACH-VOLLEYBALL	08/16/2025
GRIGOROV, KENNA BARBIERI	DISTRICT WIDE	LIMITED SUPPLY 1 OF 3	09/16/2025
GRIMALDI, COURTNEY DANIELLE	BLUE VALLEY WEST HIGH SCHOOL	5 EXTENDED DAYS-TECH INTEG SPC	08/06/2025
GRIMALDI, COURTNEY DANIELLE	BLUE VALLEY WEST HIGH SCHOOL	6 EXTENDED DAYS-DEPT CHAIR	08/06/2025



Human Resources Report to the Board of Education

Addendum

September 8, 2025

Administration recommends approval of the following actions:

GRIMALDI, COURTNEY DANIELLE	BLUE VALLEY WEST HIGH SCHOOL	8 EXTENDED DAYS-LIBR MEDIA SPC	08/06/2025
GROSPITCH, THERESA LYNN	BLUE VALLEY WEST HIGH SCHOOL	12 EXTENDED DAYS-DEPT CHAIR	08/06/2025
GROSPITCH, THERESA LYNN	DISTRICT WIDE	PDC REPRESENTATIVE	08/06/2025
GRUSENMEYER, MOLLY ANNE	PLEASANT RIDGE MIDDLE SCHOOL	ASST COACH-VOLLEYBALL	08/16/2025
GUINN, ANGELA FORD	INDIAN VALLEY ELEMENTARY	8 EXTENDED DAYS-LIBR MEDIA SPC	08/06/2025
GURWELL, NICHOLE TEICH	MORSE ELEMENTARY	16 EXTENDED DAYS-IDC	08/06/2025
GURWELL, NICHOLE TEICH	SUNSET RIDGE ELEMENTARY	16 EXTENDED DAYS-IDC	08/06/2025
GUTHRIE, ERIN D	BLUE VALLEY NORTH HIGH SCHOOL	10 EXTENDED DAYS-DEPT CHAIR	08/06/2025
HABERLY, CHRISTYN LINDSAY	VIRTUAL ED	VIRTUAL EDUCATION-FALL	08/06/2025
HADLEY, NANCY MARGARET	BLUE VALLEY NORTHWEST HS	17 EXTENDED DAYS-COUNSELOR	08/06/2025
HAGGERTY, MOLLY ANN	VIRTUAL ED	VIRTUAL EDUCATION-FALL	08/06/2025
HALL, HEATHER ELIZABETH	BLUE VALLEY WEST HIGH SCHOOL	12 EXTENDED DAYS-DEPT CHAIR	08/06/2025
HALL, HEATHER ELIZABETH	BLUE VALLEY WEST HIGH SCHOOL	ASST SPONSOR-HOSA	08/06/2025
HALL, HEATHER ELIZABETH	BLUE VALLEY WEST HIGH SCHOOL	HEAD SPONSOR-SCIENCE OLYMPIAD	08/06/2025
HAMMACK, ERICA LAINE	PRAIRIE STAR MIDDLE SCHOOL	4 EXTENDED DAYS-NURSE MS	08/06/2025
HANSEN III, WILLIAM CHRIS	BLUE VALLEY HIGH SCHOOL	17 EXTENDED DAYS-COUNSELOR	08/06/2025
HARGIS, KRISTEN T	LEAWOOD MIDDLE SCHOOL	ASST DIRECTOR-SPRING PLAY	11/16/2025
HARGIS, KRISTEN T	LEAWOOD MIDDLE SCHOOL	LEADERSHIP TEAM MEMBER	08/06/2025
HARSCH, EMILY JOAN	OVERLAND TRAIL ELEMENTARY	9 EXTENDED DAYS-COUNSELOR	08/06/2025
HARVEY, ANNE MARIE	OXFORD MIDDLE SCHOOL	8 EXTENDED DAYS-LIBR MEDIA SPC	08/06/2025
HARVEY, ANNE MARIE	OXFORD MIDDLE SCHOOL	LEADERSHIP TEAM MEMBER	08/06/2025
HASS, ERICA MARIE	PRAIRIE STAR ELEMENTARY	8 EXTENDED DAYS-LIBR MEDIA SPC	08/06/2025
HASSELL, ERIK S	OAK HILL ELEMENTARY	DIRECTOR-INSTRUMENTAL MUSIC	08/06/2025
HATFIELD, MEGAN KRISTENE	HARMONY MIDDLE SCHOOL	HEAD COACH-WRESTLING BOYS	11/16/2025
HATFIELD, MEGAN KRISTENE	HARMONY MIDDLE SCHOOL	HEAD COACH-WRESTLING GIRLS	11/16/2025
HAWKS, BRANDON T	EDUCATIONAL SUPPORT CENTER	16 EXTENDED DAYS-IDC	08/06/2025
HAWKS, BRANDON T	BLUE VALLEY SOUTHWEST HS	COORDINATOR-FOOTBALL	08/16/2025
HAYES, RENICA S	PRAIRIE STAR MIDDLE SCHOOL	ASST COACH-CROSS COUNTRY	08/16/2025
HENKE, APRIL LYNN	BLUE VALLEY HIGH SCHOOL	17 EXTENDED DAYS-COUNSELOR	08/06/2025
HILL, CHRISTINE MARIE	HILLTOP LEARNING CENTER	10 EXTENDED DAYS-SS CONSULTANT	08/06/2025
HILL, CHRISTINE MARIE	DISTRICT WIDE	PDC REPRESENTATIVE	08/06/2025
HILL, ELIZABETH ASHLEY	DISTRICT WIDE	LIMITED SUPPLY 1 OF 3	09/16/2025
HILL, SUE A	PRAIRIE STAR MIDDLE SCHOOL	ASST DIRECTOR-FALL PLAY	08/16/2025
HILLEN, KARI ANN	EDUCATIONAL SUPPORT CENTER	16 EXTENDED DAYS-IDC	08/06/2025
HILLIGOSS, LORI ANN	OVERLAND TRAIL MIDDLE SCHOOL	LEADERSHIP TEAM MEMBER	08/06/2025
HILLS, SUSAN ANN STOLL	DISTRICT WIDE	PDC REPRESENTATIVE	08/06/2025
HOFFHINES, COURTNEY JEAN	LAKWOOD ELEMENTARY	16 EXTENDED DAYS-IDC	08/06/2025
HOFFHINES, COURTNEY JEAN	HEARTLAND ELEMENTARY	16 EXTENDED DAYS-IDC	08/06/2025
HOGGATT, JENNIFER CAROL	AUBRY BEND MIDDLE SCHOOL	ASST DIRECTOR-FALL MUSICAL	08/16/2025
HOING, JENNA MARIE	BLUE VALLEY NORTHWEST HS	ASST COACH-BOYS SOCCER	08/16/2025
HOIT, LYNDI LEE	BLUE VALLEY HIGH SCHOOL	17 EXTENDED DAYS-PSYCHOLOGIST	08/06/2025
HOLLAND, TOM E	BLUE VALLEY NORTH HIGH SCHOOL	8 EXTENDED DAYS-DEPT CHAIR	08/06/2025
HOLLOWAY JR, JOHN D	BLUE VALLEY NORTH HIGH SCHOOL	8 EXTENDED DAYS-TECH INTEG SPC	08/06/2025
HOLMES, ELIOT KEITH	DISTRICT WIDE	PDC REPRESENTATIVE	08/06/2025



Human Resources Report to the Board of Education

Addendum

September 8, 2025

Administration recommends approval of the following actions:

HOLOVACH, AMY G	VALLEY PARK ELEMENTARY	17 EXTENDED DAYS-PSYCHOLOGIST	08/06/2025
HOLSAPPLE, WILLIAM RIKER	LAKEWOOD MIDDLE SCHOOL	ASST COACH-VOLLEYBALL	08/16/2025
HOSTETTER, KAYLEE BROOKE	DISTRICT WIDE	LIMITED SUPPLY 1 OF 3	09/16/2025
HOWARD, DEREK LEE	BLUE VALLEY WEST HIGH SCHOOL	6 EXTENDED DAYS-DEPT CHAIR	08/06/2025
HOWARD, GARY LEON	BLUE VALLEY NORTHWEST HS	20 EXD ADMIIN CONSULTANT	08/06/2025
HOWE, AMY ELIZABETH	HILLTOP LEARNING CENTER	10 EXTENDED DAYS-SS CONSULTANT	08/06/2025
HUBENER, JACQUELINE FAY	HARMONY MIDDLE SCHOOL	LEADERSHIP TEAM MEMBER	08/06/2025
HUDNALL, SYDNEY MARIE	ASPEN GROVE ELEMENTARY	2 EXTENDED DAYS-NURSE ES	08/06/2025
HUME, WILLIAM EDWARD	BLUE VALLEY HIGH SCHOOL	8 EXTENDED DAYS-LIBR MEDIA SPC	08/06/2025
HUMPHREVILLE, MELISSA ACKER	OVERLAND TRAIL MIDDLE SCHOOL	ASST COACH-VOLLEYBALL	08/16/2025
HUMPHREVILLE, MELISSA ACKER	DISTRICT WIDE	LIMITED SUPPLY 1 OF 3	09/16/2025
HUNT, ELYSE E	OVERLAND TRAIL MIDDLE SCHOOL	LEADERSHIP TEAM MEMBER	08/06/2025
HUNT, ELYSE E	OVERLAND TRAIL MIDDLE SCHOOL	TEAM LEADER-OTHER RESP	08/06/2025
HURLBUT, ERICA LAIRD	HARMONY MIDDLE SCHOOL	MS COORDINATOR-TECHNOLOGY	08/06/2025
HURST, CECILY FAITH	DISTRICT WIDE	LIMITED SUPPLY 1 OF 3	09/16/2025
HURST, LAURA JOANN	LEAWOOD MIDDLE SCHOOL	ASST DIRECTOR-FALL MUSICAL	08/16/2025
HURST, LAURA JOANN	LEAWOOD MIDDLE SCHOOL	ASST DIRECTOR-SPRING PLAY	03/01/2026
HURT, COURTNEY CONNOLLY	HILLTOP LEARNING CENTER	10 EXTENDED DAYS-SS CONSULTANT	08/06/2025
IHM, AARON NIEL	BLUE VALLEY NORTHWEST HS	SUPERVISOR-STADIUM	08/06/2025
ILLUM, KATHARINE	WOLF SPRINGS ELEMENTARY	2 EXTENDED DAYS-NURSE ES	08/06/2025
JAMES, JEAN CAITLIN	HILLTOP LEARNING CENTER	10 EXTENDED DAYS-SS CONSULTANT	08/06/2025
JANDA, JULIA MARIA	PRAIRIE STAR MIDDLE SCHOOL	DIRECTOR-BAND	08/06/2025
JENSEN, ELISA LYNN	LEAWOOD MIDDLE SCHOOL	LEADERSHIP TEAM MEMBER	08/06/2025
JENSEN, ELISA LYNN	LEAWOOD MIDDLE SCHOOL	SPONSOR-DRILL/DANCE TEAM	08/06/2025
JIROVEC, DONNA MARIE	HILLTOP LEARNING CENTER	10 EXTENDED DAYS-SS CONSULTANT	08/06/2025
JOHNSON, ELAINE M	COTTONWOOD POINT ELEMENTARY	8 EXTENDED DAYS-LIBR MEDIA SPC	08/06/2025
JOHNSON, MINDRAWATI ASTUTI	BLUE VALLEY MIDDLE SCHOOL	ASST DIRECTOR-FALL PLAY	08/16/2025
JOHNSTON, MICHAEL A	BLUE VALLEY HIGH SCHOOL	8 EXTENDED DAYS-DEPT CHAIR	08/06/2025
JONASON, ANNE	DISTRICT WIDE	PDC REPRESENTATIVE	08/06/2025
JONES, ABIGAIL ROSE	MISSION TRAIL ELEMENTARY	8 EXTENDED DAYS-LIBR MEDIA SPC	08/06/2025
JONES, ABIGAIL ROSE	DISTRICT WIDE	PDC REPRESENTATIVE	08/06/2025
JORDAN, BRETT ANTHONY	BLUE VALLEY HIGH SCHOOL	ASST COACH-DEBATE	08/16/2025
JURKOVAC, JESSICA E	BLUE VALLEY SOUTHWEST HS	8 EXTENDED DAYS-LIBR MEDIA SPC	08/06/2025
KANAN, WILLIAM HENRY	LEAWOOD MIDDLE SCHOOL	LEADERSHIP TEAM MEMBER	08/06/2025
KANAREK, ELI S	BLUE VALLEY HIGH SCHOOL	8 EXTENDED DAYS-DEPT CHAIR	08/06/2025
KEARNEY, JULIE RENE	WOLF SPRINGS ELEMENTARY	17 EXTENDED DAYS-PSYCHOLOGIST	08/06/2025
KELLER, STEPHANIE SUSAN	BLUE VALLEY NORTHWEST HS	17 EXTENDED DAYS-COUNSELOR	08/06/2025
KELLER, STEPHANIE SUSAN	DISTRICT WIDE	PDC REPRESENTATIVE	08/06/2025
KENNEDY, AUBREY MCCORD	PLEASANT RIDGE MIDDLE SCHOOL	8 EXTENDED DAYS-LIBR MEDIA SPC	08/06/2025
KENNEDY, TIMOTHY J	BLUE VALLEY HIGH SCHOOL	SUPERVISOR-GYMNASIUM	11/16/2025
KENNEY, MARK V	LAKEWOOD MIDDLE SCHOOL	17 EXTENDED DAYS-PSYCHOLOGIST	08/06/2025
KESSLER, ERIC M	CENTER FOR ADV PROF STUDIES	8 EXTENDED DAYS-STRAND LEADER	08/06/2025
KIMBROUGH, CARLY GIFFEN	BLUE VALLEY NORTHWEST HS	ASST DIRECTOR-WINTER MUSICAL	11/16/2025
KINCAID, TYLER SCOTT	BLUE VALLEY SOUTHWEST HS	ASST COACH-FOOTBALL	08/16/2025



Human Resources Report to the Board of Education

Addendum

September 8, 2025

Administration recommends approval of the following actions:

KINGETER, ROBIN SCHEMMEL	HARMONY MIDDLE SCHOOL	MS COORDINATOR-INTERVENTION	08/06/2025
KIRK, DELANEY LOGAN	LIBERTY VIEW ELEMENTARY	DIRECTOR-VOCAL MUSIC	08/06/2025
KNEIB, KADI L	INDIAN VALLEY ELEMENTARY	9 EXTENDED DAYS-COUNSELOR	08/06/2025
KNIGHT, MISTY BETH	PRAIRIE STAR MIDDLE SCHOOL	LEADERSHIP TEAM MEMBER	08/06/2025
KNIGHT, MISTY BETH	PRAIRIE STAR MIDDLE SCHOOL	MS COORDINATOR-MATH	08/06/2025
KNOLL, GRANT A	PLEASANT RIDGE MIDDLE SCHOOL	LEADERSHIP TEAM MEMBER	08/06/2025
KOCH, BARRET LUCAS	LEAWOOD MIDDLE SCHOOL	17 EXTENDED DAYS-PSYCHOLOGIST	08/06/2025
KOCH, BARRET LUCAS	AUBRY BEND MIDDLE SCHOOL	17 EXTENDED DAYS-PSYCHOLOGIST	08/06/2025
KOCH, KARENE NICHOLE	DISTRICT WIDE	PDC REPRESENTATIVE	08/06/2025
KOONTZ, COURTNEY RENEE	DISTRICT WIDE	LIMITED SUPPLY 1 OF 3	09/16/2025
KOTECHA, AMY NICHOLE	MISSION TRAIL ELEMENTARY	2 EXTENDED DAYS-NURSE ES	08/06/2025
KREWSON, SICILEY P	BLUE VALLEY SOUTHWEST HS	12 EXTENDED DAYS-DEPT CHAIR	08/06/2025
KROEKER, BRIAN SCOTT	BLUE VALLEY WEST HIGH SCHOOL	6 EXTENDED DAYS-DEPT CHAIR	08/06/2025
KROUSE, CASEY ANNE	EDUCATIONAL SUPPORT CENTER	16 EXTENDED DAYS-IDC	08/06/2025
KURIMSKY, MICHELE SUZANNE	SUNRISE POINT ELEMENTARY	8 EXTENDED DAYS-LIBR MEDIA SPC	08/06/2025
LABELLE, EMILY C	PRAIRIE STAR MIDDLE SCHOOL	LEADERSHIP TEAM MEMBER	08/06/2025
LAHASKY, ALEX W	BLUE VALLEY WEST HIGH SCHOOL	12 EXTENDED DAYS-DEPT CHAIR	08/06/2025
LAHASKY, ALEX W	BLUE VALLEY WEST HIGH SCHOOL	6 EXTENDED DAYS-DEPT CHAIR	08/06/2025
LAHASKY, JENNIFER LYNN	LEAWOOD MIDDLE SCHOOL	ASST DIRECTOR-FALL MUSICAL	08/16/2025
LAHASKY, JENNIFER LYNN	LEAWOOD MIDDLE SCHOOL	LEADERSHIP TEAM MEMBER	08/06/2025
LANG, PAIGE M	OAK HILL ELEMENTARY	2 EXTENDED DAYS-NURSE ES	08/06/2025
LANGE, JULIA CHRISTINE	PRAIRIE STAR ELEMENTARY	16 EXTENDED DAYS-IDC	08/06/2025
LANGE, JULIA CHRISTINE	BLUE RIVER ELEMENTARY	16 EXTENDED DAYS-IDC	08/06/2025
LAPEE, CHRISTOPHER DAWSON	BLUE VALLEY SOUTHWEST HS	ASST COACH-DEBATE	08/16/2025
LARAMORE, GRANT BENJAMIN	BLUE VALLEY WEST HIGH SCHOOL	ASST COACH-DEBATE	08/16/2025
LASCHE, TYLER S	AUBRY BEND MIDDLE SCHOOL	ASST DIRECTOR-FALL MUSICAL	08/16/2025
LASCHE, TYLER S	LEAWOOD MIDDLE SCHOOL	ASST DIRECTOR-FALL MUSICAL	08/16/2025
LASCHE, TYLER S	LEAWOOD MIDDLE SCHOOL	ASST DIRECTOR-SPRING PLAY	11/16/2025
LASHLEY, TAMARA DAWN	DISTRICT WIDE	PDC REPRESENTATIVE	08/06/2025
LEVIN, AMANDA ROSE	BLUE VALLEY NORTH HIGH SCHOOL	17 EXTENDED DAYS-COUNSELOR	08/06/2025
LEVIN, AMANDA ROSE	BLUE VALLEY NORTH HIGH SCHOOL	4 EXTENDED DAYS-DEPT CHAIR	08/06/2025
LEVY, BENJAMIN JOSEPH	BLUE VALLEY NORTH HIGH SCHOOL	10 EXTENDED DAYS-DEPT CHAIR	08/06/2025
LEWIS, MARY KATHLEEN	DISTRICT WIDE	LIMITED SUPPLY 1 OF 3	09/16/2025
LINNER, CHRISTOPHER MAHLON	BLUE VALLEY NORTHWEST HS	SUPERVISOR-STADIUM	08/06/2025
LIPOSCHAK, SYDNEY ANNE	BLUE VALLEY MIDDLE SCHOOL	LEADERSHIP TEAM MEMBER	08/06/2025
LISTER, BRIDGET BAKER	HARMONY MIDDLE SCHOOL	LEADERSHIP TEAM MEMBER	08/06/2025
LOEWEN, ETHAN LAMONT	LAKWOOD ELEMENTARY	DIRECTOR-INSTRUMENTAL MUSIC	08/06/2025
LOMEN, TWYLA LEE	BLUE VALLEY MIDDLE SCHOOL	ASST DIRECTOR-FALL PLAY	08/16/2025
LOMEN, TWYLA LEE	DISTRICT WIDE	LIMITED SUPPLY 1 OF 3	09/16/2025
LONG, FLORENCE WETZEL	DISTRICT WIDE	PDC REPRESENTATIVE	08/06/2025
LOWE, RANDALL	PLEASANT RIDGE MIDDLE SCHOOL	ASST COACH-FOOTBALL	08/16/2025
LUAL, BUOMKUOTH P	OVERLAND TRAIL MIDDLE SCHOOL	17 EXTENDED DAYS-COUNSELOR	08/06/2025
LUJANO, CAROL I	INDIAN VALLEY ELEMENTARY	17 EXTENDED DAYS-PSYCHOLOGIST	08/06/2025
LUJANO, CAROL I	STANLEY ELEMENTARY	17 EXTENDED DAYS-PSYCHOLOGIST	08/06/2025



Human Resources Report to the Board of Education

Addendum

September 8, 2025

Administration recommends approval of the following actions:

LUNDINE, ADAM HARLAN	EDUCATIONAL SUPPORT CENTER	16 EXTENDED DAYS-DCT	08/06/2025
LYCHE, ABIGAIL G	PLEASANT RIDGE MIDDLE SCHOOL	DIRECTOR-BAND	08/06/2025
LYNN, JENNIFER ELIZABETH	LAKEWOOD ELEMENTARY	DIRECTOR-VOCAL MUSIC	08/06/2025
MAAS, SARAH JEAN	DISTRICT WIDE	LIMITED SUPPLY 1 OF 3	09/16/2025
MADDEN, LILLIAN MARIE	LEAWOOD MIDDLE SCHOOL	LEADERSHIP TEAM MEMBER	08/06/2025
MADDOX, SARA FRANCES	CEDAR HILLS ELEMENTARY	9 EXTENDED DAYS-COUNSELOR	08/06/2025
MADIGAN, LINDSAY ILSE	DISTRICT WIDE	LIMITED SUPPLY 1 OF 3	09/16/2025
MADISON, SHANNON LEA	PLEASANT RIDGE MIDDLE SCHOOL	LEADERSHIP TEAM MEMBER	08/06/2025
MADSEN, TRICIA LOUISE	HARMONY MIDDLE SCHOOL	17 EXTENDED DAYS-COUNSELOR	08/06/2025
MADSEN, TRICIA LOUISE	HARMONY MIDDLE SCHOOL	LEADERSHIP TEAM MEMBER	08/06/2025
MAHONEY, MOLLY ELIZABETH	TIMBER CREEK ELEMENTARY	2 EXTENDED DAYS-NURSE ES	08/06/2025
MAHR, MOLLIE MCCLANAHAN	AUBRY BEND MIDDLE SCHOOL	ASST COACH-VOLLEYBALL	08/16/2025
MAINS, ANNE ELIZABETH	MORSE ELEMENTARY	17 EXTENDED DAYS-PSYCHOLOGIST	08/06/2025
MANNA, JACOB MICHAEL	BLUE VALLEY WEST HIGH SCHOOL	ASST DIRECTOR-MARCHING BAND	08/16/2025
MARSHALL, ZAKIAH	HEARTLAND ELEMENTARY	17 EXTENDED DAYS-PSYCHOLOGIST	08/06/2025
MARSHALL, ZAKIAH	SUNSET RIDGE ELEMENTARY	17 EXTENDED DAYS-PSYCHOLOGIST	08/06/2025
MARTENS, LAUREN	WOLF SPRINGS ELEMENTARY	DIRECTOR-INSTRUMENTAL MUSIC	08/06/2025
MARTENS, LAUREN	MORSE ELEMENTARY	DIRECTOR-INSTRUMENTAL MUSIC	08/06/2025
MARTIN, VALERIE LYNN	BLUE VALLEY WEST HIGH SCHOOL	ASST DIRECTOR-WINTER MUSICAL	11/16/2025
MARTINEK, MICHELE LYNN	HILLTOP LEARNING CENTER	10 EXTENDED DAYS-SS CONSULTANT	08/06/2025
MASON, ALLISON MICHELLE	PLEASANT RIDGE MIDDLE SCHOOL	ASST DIRECTOR-FALL PLAY	08/16/2025
MASON, ALLISON MICHELLE	PLEASANT RIDGE MIDDLE SCHOOL	LEADERSHIP TEAM MEMBER	08/06/2025
MASON, ALLISON MICHELLE	DISTRICT WIDE	PDC REPRESENTATIVE	08/06/2025
MASON, JODY OELLIEN	OVERLAND TRAIL ELEMENTARY	8 EXTENDED DAYS-LIBR MEDIA SPC	08/06/2025
MASON, KATHERINE IRENE	ASPEN GROVE ELEMENTARY	DIRECTOR-CHOIR	08/06/2025
MASON, KATHERINE IRENE	STILWELL ELEMENTARY	DIRECTOR-CHOIR	08/06/2025
MASON, KATHERINE IRENE	STILWELL ELEMENTARY	DIRECTOR-VOCAL MUSIC	08/06/2025
MASON, KATHERINE IRENE	ASPEN GROVE ELEMENTARY	DIRECTOR-VOCAL MUSIC	08/06/2025
MATTSON, JENNIFER ANN	DISTRICT WIDE	NATIONAL BOARD CERTIFICATION	08/01/2025
MAYERS, TRACIE LYNN	HEARTLAND ELEMENTARY	2 EXTENDED DAYS-NURSE ES	08/06/2025
MAYFIELD, JORDAN CHRISTOPHER	BLUE VALLEY NORTHWEST HS	ASST COACH-FOOTBALL	08/16/2025
MAZZAPICA, KARRI LEE	BLUE VALLEY MIDDLE SCHOOL	ASST DIRECTOR-FALL PLAY	08/16/2025
MAZZAPICA, KARRI LEE	BLUE VALLEY MIDDLE SCHOOL	LEADERSHIP TEAM MEMBER	08/06/2025
MCCARTHY, ERICA D	DISTRICT WIDE	LIMITED SUPPLY 1 OF 3	09/16/2025
MCCASLIN, PAIGE	SUNRISE POINT ELEMENTARY	9 EXTENDED DAYS-COUNSELOR	08/06/2025
MCCORMICK, JOHN ANDREW	EDUCATIONAL SUPPORT CENTER	16 EXTENDED DAYS-IDC	08/06/2025
MCELROY, BRYCE AVIN	BLUE VALLEY WEST HIGH SCHOOL	20 EXTENDED DAYS-ADMIN INTERN	08/06/2025
MCELROY, BRYCE AVIN	BLUE VALLEY WEST HIGH SCHOOL	AD INTERN SUPERVISION DUTIES	08/06/2025
MCELROY, BRYCE AVIN	DISTRICT WIDE	LIMITED SUPPLY 1 OF 1	09/16/2025
MCENTIRE, BARBARA L	OVERLAND TRAIL MIDDLE SCHOOL	TEAM LEADER-OTHER RESP	08/06/2025
MCGIBBONEY II, ORLANDO DAVID	BLUE VALLEY NORTHWEST HS	ASST COACH-FOOTBALL	08/16/2025
MCKEE, MALLORY KAITLYN	LAKEWOOD MIDDLE SCHOOL	LEADERSHIP TEAM MEMBER	08/06/2025
MCKEE, MALLORY KAITLYN	LAKEWOOD MIDDLE SCHOOL	TEAM LEADER-GRADE 7	08/06/2025
MCKEE, SARAH MARGARET	BLUE VALLEY SOUTHWEST HS	6 EXTENDED DAYS-DEPT CHAIR	08/06/2025



Human Resources Report to the Board of Education

Addendum

September 8, 2025

Administration recommends approval of the following actions:

MCLAUGHLIN, TANNER D	HILLTOP LEARNING CENTER	10 EXTENDED DAYS-SS CONSULTANT	08/06/2025
MCVEY, KEELEY R	DISTRICT WIDE	LIMITED SUPPLY 1 OF 3	09/16/2025
MEEK, ALYSIA DIANE	HARMONY MIDDLE SCHOOL	LEADERSHIP TEAM MEMBER	08/06/2025
MEEK, STEPHANIE A	PLEASANT RIDGE MIDDLE SCHOOL	17 EXTENDED DAYS-COUNSELOR	08/06/2025
MEEK, STEPHANIE A	PLEASANT RIDGE MIDDLE SCHOOL	ASST COACH-VOLLEYBALL	08/16/2025
MEEK, STEPHANIE A	PLEASANT RIDGE MIDDLE SCHOOL	LEADERSHIP TEAM MEMBER	08/06/2025
MEISINGER, PEYTON JEAN	SERVICE CENTER	10 EXTENDED DAYS-SS CONSULTANT	08/06/2025
MEISSNER, JESSICA L	AUBRY BEND MIDDLE SCHOOL	LEADERSHIP TEAM MEMBER	08/06/2025
METTLACH, CYNTHIA N	LEAWOOD MIDDLE SCHOOL	ASST COACH-VOLLEYBALL	08/16/2025
MEYER, JASON E	OXFORD MIDDLE SCHOOL	DIRECTOR-VOCAL MUSIC	08/06/2025
MEYER, JASON E	BLUE VALLEY NORTHWEST HS	DIRECTOR-VOCAL MUSIC	08/06/2025
MIDDLETON, THERESA JEANNE	BLUE VALLEY WEST HIGH SCHOOL	17 EXTENDED DAYS-COUNSELOR	08/06/2025
MILLER, CARRIE LYNN	PLEASANT RIDGE MIDDLE SCHOOL	17 EXTENDED DAYS-COUNSELOR	08/06/2025
MILLER, CARRIE LYNN	PLEASANT RIDGE MIDDLE SCHOOL	LEADERSHIP TEAM MEMBER	08/06/2025
MILLS, HEATHER L	PLEASANT RIDGE MIDDLE SCHOOL	ASST COACH-CROSS COUNTRY	08/16/2025
MITCHEM, HILARY ANN	PLEASANT RIDGE MIDDLE SCHOOL	LEADERSHIP TEAM MEMBER	08/06/2025
MODELSKI, KIMBERLY ANN	BLUE VALLEY WEST HIGH SCHOOL	6 EXTENDED DAYS-DEPT CHAIR	08/06/2025
MONSEES, KYLE EDWARD	EDUCATIONAL SUPPORT CENTER	16 EXTENDED DAYS-IDC	08/06/2025
MONSON, ANDREW JAMES	LIBERTY VIEW ELEMENTARY	DIRECTOR-INSTRUMENTAL MUSIC	08/06/2025
MONSON, ANDREW JAMES	SUNSET RIDGE ELEMENTARY	DIRECTOR-INSTRUMENTAL MUSIC	08/06/2025
MONTGOMERY, MORGAN LYNN	HILLTOP LEARNING CENTER	10 EXTENDED DAYS-SS CONSULTANT	08/06/2025
MOORE, CANDY DIANE	BLUE VALLEY HIGH SCHOOL	17 EXTENDED DAYS-COUNSELOR	08/06/2025
MORRISON, CHRISTA NOEL	MORSE ELEMENTARY	DIRECTOR-CHOIR	08/06/2025
MORRISON, CHRISTA NOEL	MORSE ELEMENTARY	DIRECTOR-VOCAL MUSIC	08/06/2025
MORSE, TINA MARIE	BLUE VALLEY NORTH HIGH SCHOOL	ASST COACH-SOFTBALL	03/01/2026
MOSS, ELIJAH COLEMAN	AUBRY BEND MIDDLE SCHOOL	LEADERSHIP TEAM MEMBER	08/06/2025
MOUSE, KELSEY ELIZABETH	EDUCATIONAL SUPPORT CENTER	16 EXTENDED DAYS-IDC	08/06/2025
MOWRY, BRIAN JAMES	BLUE VALLEY HIGH SCHOOL	12 EXTENDED DAYS-DEPT CHAIR	08/06/2025
MUDD, BLAKE E	BLUE VALLEY NORTH HIGH SCHOOL	ADDL TEACHING SUPV-2ND SEM	01/05/2026
MUDD, BLAKE E	BLUE VALLEY NORTH HIGH SCHOOL	COORDINATOR-FOOTBALL	08/16/2025
MUDD, BLAKE E	DISTRICT WIDE	LIMITED SUPPLY 1 OF 3	09/16/2025
MULHOLLAND, JENNIFER MARIE	MORSE ELEMENTARY	9 EXTENDED DAYS-COUNSELOR	08/06/2025
MULLENIX, KIMBRA ANN	HILLTOP LEARNING CENTER	17 EXTENDED DAYS-PSYCHOLOGIST	08/06/2025
MUNSON, REBECCA STITH	SUPPORT SERVICES CENTER	24 EXTENDED DAYS-COORD LIB SYS	08/06/2025
MURKIN, HALEY N	BLUE VALLEY NORTHWEST HS	5 EXTENDED DAYS-NURSE HS	08/06/2025
MURPHY-DYER, MALLORY ERIN	HARMONY ELEMENTARY	DIRECTOR-CHOIR	08/06/2025
MURPHY-DYER, MALLORY ERIN	HARMONY ELEMENTARY	DIRECTOR-VOCAL MUSIC	08/06/2025
MURRAY, DEBORAH LOUISE	OVERLAND TRAIL MIDDLE SCHOOL	17 EXTENDED DAYS-PSYCHOLOGIST	08/06/2025
MURRAY, DEBORAH LOUISE	COTTONWOOD POINT ELEMENTARY	17 EXTENDED DAYS-PSYCHOLOGIST	08/06/2025
MURRAY, RYAN CHRISTOPHER	PRAIRIE STAR MIDDLE SCHOOL	ASST COACH-FOOTBALL	08/16/2025
MURRAY, RYAN CHRISTOPHER	PRAIRIE STAR MIDDLE SCHOOL	LEADERSHIP TEAM MEMBER	08/06/2025
MYERS, CARRIE ANN	EDUCATIONAL SUPPORT CENTER	45 EXTENDED DAYS-BVEA	08/06/2025
NADEN, PAULA MARIE	TIMBER CREEK ELEMENTARY	8 EXTENDED DAYS-LIBR MEDIA SPC	08/06/2025
NAVARRO, NICOLAS ALEXANDER	BLUE VALLEY NORTH HIGH SCHOOL	ASST COACH-GIRLS SOCCER	03/01/2026



Human Resources Report to the Board of Education

Addendum

September 8, 2025

Administration recommends approval of the following actions:

NEITZEL, AARON FRANCIS	PRAIRIE STAR ELEMENTARY	17 EXTENDED DAYS-PSYCHOLOGIST	08/06/2025
NEITZEL, AARON FRANCIS	PRAIRIE STAR MIDDLE SCHOOL	17 EXTENDED DAYS-PSYCHOLOGIST	08/06/2025
NELSON, JORDAN KALENE	DISTRICT WIDE	LIMITED SUPPLY 1 OF 3	09/16/2025
NENEMAN, CAITLIN MARJORIE	BLUE VALLEY HIGH SCHOOL	8 EXTENDED DAYS-LIBR MEDIA SPC	08/06/2025
NEWELL, LUCAS A	OVERLAND TRAIL MIDDLE SCHOOL	LEADERSHIP TEAM MEMBER	08/06/2025
NEWTON, CHELSI ANN	STILWELL ELEMENTARY	2 EXTENDED DAYS-NURSE ES	08/06/2025
NOCITA, LISA THOMAS	PRAIRIE STAR MIDDLE SCHOOL	8 EXTENDED DAYS-LIBR MEDIA SPC	08/06/2025
NOCITA, LISA THOMAS	PRAIRIE STAR MIDDLE SCHOOL	LEADERSHIP TEAM MEMBER	08/06/2025
NOCITA, LISA THOMAS	DISTRICT WIDE	PDC REPRESENTATIVE	08/06/2025
NORTON MOLAND, ERYN ANNELLE	DISTRICT WIDE	LIMITED SUPPLY 1 OF 3	09/16/2025
NORTON, BARBARA JO	LEAWOOD MIDDLE SCHOOL	8 EXTENDED DAYS-LIBR MEDIA SPC	08/06/2025
NORVAL, ALEXANDRIA NICOLE	BLUE VALLEY NORTH HIGH SCHOOL	5 EXTENDED DAYS-NURSE HS	08/06/2025
O'BRYAN, DIANNE LYNN	BLUE VALLEY HIGH SCHOOL	13 EXTENDED DAYS-COORD TEACHER	08/06/2025
O'LEARY, KATELYN HANNAH	HILLTOP LEARNING CENTER	10 EXTENDED DAYS-SS CONSULTANT	08/06/2025
O'NEAL, KRISTI RENAE	PLEASANT RIDGE MIDDLE SCHOOL	TEAM LEADER-GRADE 7	08/06/2025
OCON JR, JUAN	BLUE VALLEY NORTH HIGH SCHOOL	ASST COACH-BOYS SOCCER	08/16/2025
ODDO, KATHRYN ELIZABETH	HARMONY ELEMENTARY	16 EXTENDED DAYS-ADMIN INTERN	08/06/2025
ODLE, CRAIG TAYLOR	BLUE VALLEY NORTHWEST HS	8 EXTENDED DAYS-LIBR MEDIA SPC	08/06/2025
OHMES, ANNA ELIZABETH	LAKEWOOD MIDDLE SCHOOL	LEADERSHIP TEAM MEMBER	08/06/2025
OLDSON, MCKENNA LEE	HARMONY MIDDLE SCHOOL	HEAD SPONSOR-SCIENCE OLYMPIAD	08/06/2025
OLDSON, MCKENNA LEE	HARMONY MIDDLE SCHOOL	MS COORDINATOR-INTERVENTION	08/06/2025
OLLIG, CHRIS B	BLUE VALLEY NORTH HIGH SCHOOL	12 EXTENDED DAYS-DEPT CHAIR	08/06/2025
OPP, CHRISTOPHER PATRICK	PLEASANT RIDGE MIDDLE SCHOOL	ASST COACH-FOOTBALL	08/16/2025
ORRICK, ANTHONY JOHN	BLUE VALLEY SOUTHWEST HS	5 EXTENDED DAYS-DEPT CHAIR	08/06/2025
ORRICK, ZACHARY JORDAN	BLUE VALLEY NORTHWEST HS	SUPERVISOR-GYMNASIUM	11/16/2025
ORTIZ, DENISE A	HARMONY ELEMENTARY	17 EXTENDED DAYS-PSYCHOLOGIST	08/06/2025
ORTIZ, DENISE A	OVERLAND TRAIL ELEMENTARY	17 EXTENDED DAYS-PSYCHOLOGIST	08/06/2025
OSTMEYER, KAREN NASON	PLEASANT RIDGE MIDDLE SCHOOL	4 EXTENDED DAYS-NURSE MS	08/06/2025
PACHECO, CARLOS	BLUE VALLEY WEST HIGH SCHOOL	ASST DIRECTOR-MARCHING BAND	08/16/2025
PALERMO, CHERIN LYNN	LEAWOOD MIDDLE SCHOOL	ASST COACH-VOLLEYBALL	08/16/2025
PALERMO, CHERIN LYNN	LEAWOOD MIDDLE SCHOOL	LEADERSHIP TEAM MEMBER	08/06/2025
PALMGREN JR, ROBERT MICHAEL	BLUE VALLEY SOUTHWEST HS	10 EXTENDED DAYS-DEPT CHAIR	08/06/2025
PARKER, HALEY NICOLE	HILLTOP LEARNING CENTER	10 EXTENDED DAYS-SS CONSULTANT	08/06/2025
PARKER, KATHRYN ANN	OVERLAND TRAIL ELEMENTARY	16 EXTENDED DAYS-IDC	08/06/2025
PARKS, KATIE ROSE BARTOLAC	SUPPORT SERVICES CENTER	20 EXD-COORDINATOR DIGITAL RES	08/06/2025
PAYNE, HEATHER LYNN	WOLF SPRINGS ELEMENTARY	16 EXTENDED DAYS-ADMIN INTERN	08/06/2025
PEARSON, KATHRYN IDA ANN	BLUE VALLEY NORTH HIGH SCHOOL	20 EXTENDED DAYS-ADMIN INTERN	08/06/2025
PELATE, KALA MARIE	BLUE RIVER ELEMENTARY	9 EXTENDED DAYS-COUNSELOR	08/06/2025
PEPPER, KATE ELLEN	LAKEWOOD MIDDLE SCHOOL	HEAD SPONSOR-SCIENCE OLYMPIAD	08/06/2025
PERES, KATHY L	BLUE VALLEY HIGH SCHOOL	8 EXTENDED DAYS-DEPT CHAIR	08/06/2025
PERRY, REBECCA SUZANNE	AUBRY BEND MIDDLE SCHOOL	ASST DIRECTOR-FALL MUSICAL	08/16/2025
PETERSON, RALEIGH ANNE	OVERLAND TRAIL MIDDLE SCHOOL	ASST DIRECTOR-FALL MUSICAL	08/16/2025
PETERSON, SARAH JEAN	HARMONY MIDDLE SCHOOL	LEADERSHIP TEAM MEMBER	08/06/2025
PETRICH, BRITTANY RENEE	OVERLAND TRAIL MIDDLE SCHOOL	4 EXTENDED DAYS-NURSE MS	08/06/2025



Human Resources Report to the Board of Education

Addendum

September 8, 2025

Administration recommends approval of the following actions:

PICKERT, AZADEH TAGHIZADEH	BLUE VALLEY HIGH SCHOOL	12 EXTENDED DAYS-DEPT CHAIR	08/06/2025
PICKERT, AZADEH TAGHIZADEH	BLUE VALLEY HIGH SCHOOL	13 EXTENDED DAYS-COORD TEACHER	08/06/2025
PITTMAN, JOSEPH KEIL	BLUE VALLEY HIGH SCHOOL	8 EXTENDED DAYS-TECH INTEG SPC	08/06/2025
PITTMAN, JOSEPH KEIL	DISTRICT WIDE	PDC REPRESENTATIVE	08/06/2025
POESCHL, SARAH J	DISTRICT WIDE	LIMITED SUPPLY 1 OF 3	09/16/2025
POMMERENKE, KATHLEEN CLAIRE	BLUE VALLEY NORTH HIGH SCHOOL	8 EXTENDED DAYS-LIBR MEDIA SPC	08/06/2025
POPE, SARAH REESE	OVERLAND TRAIL MIDDLE SCHOOL	16 EXTENDED DAYS-IDC	08/06/2025
POSKIN, BROOKE A	BLUE VALLEY HIGH SCHOOL	COORDINATOR-PROM	08/06/2025
PRATER, LINDSAY CARTHLEENA	BLUE RIVER ELEMENTARY	DIRECTOR-VOCAL MUSIC	08/06/2025
PRICE, JANE K	DISTRICT WIDE	PDC REPRESENTATIVE	08/06/2025
PULCINI, ROBERT DANIEL	AUBRY BEND MIDDLE SCHOOL	17 EXTENDED DAYS-COUNSELOR	08/06/2025
PURIN, PETER C	PRAIRIE STAR MIDDLE SCHOOL	DIRECTOR-ENRICHMENT CHOIR	08/06/2025
PUTZIER, JEBEDIAH LEE	PRAIRIE STAR MIDDLE SCHOOL	ASST COACH-FOOTBALL	08/16/2025
QUIASON, JESSICA MARIE	OXFORD MIDDLE SCHOOL	LEADERSHIP TEAM MEMBER	08/06/2025
QUINN, ROXANNE HAZEL	OVERLAND TRAIL MIDDLE SCHOOL	17 EXTENDED DAYS-COUNSELOR	08/06/2025
QUINN, ROXANNE HAZEL	OVERLAND TRAIL MIDDLE SCHOOL	LEADERSHIP TEAM MEMBER	08/06/2025
RABBITT, JOCELYN RENEE	HILLTOP LEARNING CENTER	10 EXTENDED DAYS-SS CONSULTANT	08/06/2025
RAMPY, ZACH	BLUE VALLEY WEST HIGH SCHOOL	ASST COACH-FOOTBALL	08/16/2025
RAMSTAD, SYBIL CLAIRE	LEAWOOD MIDDLE SCHOOL	ASST COACH-CROSS COUNTRY	08/16/2025
RATHBONE, BRODERIC R	LEAWOOD MIDDLE SCHOOL	ASST COACH-BOYS BASKETBALL	11/16/2025
RATHJEN, MIA MARIE	PRAIRIE STAR MIDDLE SCHOOL	ASST COACH-VOLLEYBALL	08/16/2025
RATZLAFF, TARA NICOLE	DISTRICT WIDE	PDC REPRESENTATIVE	08/06/2025
REDLIN, MAKELA ANN	AUBRY BEND MIDDLE SCHOOL	ASST COACH-CROSS COUNTRY	08/16/2025
REED, VICTORIA JEAN	DISTRICT WIDE	PDC REPRESENTATIVE	08/06/2025
REED, ZOIE R	BLUE VALLEY WEST HIGH SCHOOL	ASST COACH-CROSS COUNTRY	08/16/2025
RELPHORDE, MARCUS JERRAD	BLUE VALLEY WEST HIGH SCHOOL	17 EXTENDED DAYS-COUNSELOR	08/06/2025
RESTIVO, LAURA M	BLUE VALLEY WEST HIGH SCHOOL	12 EXTENDED DAYS-DEPT CHAIR	08/06/2025
REYNOLDS, RUBY ANN	DISTRICT WIDE	LIMITED SUPPLY 1 OF 3	09/16/2025
REYNOLDS, TINA DENAY	PRAIRIE STAR MIDDLE SCHOOL	17 EXTENDED DAYS-COUNSELOR	08/06/2025
RHOADES, JENNIFER MARIE	DISTRICT WIDE	LIMITED SUPPLY 1 OF 3	09/16/2025
RICCARDI, KELLEY SUZANNE	BLUE VALLEY HIGH SCHOOL	5 EXTENDED DAYS-NURSE HS	08/06/2025
RICHARDS, CHRISTINE ROBERTA	PRAIRIE STAR MIDDLE SCHOOL	17 EXTENDED DAYS-COUNSELOR	08/06/2025
RICHARDS, CHRISTINE ROBERTA	PRAIRIE STAR MIDDLE SCHOOL	LEADERSHIP TEAM MEMBER	08/06/2025
RICKE, ELIZABETH ANNE	BLUE VALLEY NORTHWEST HS	17 EXTENDED DAYS-COUNSELOR	08/06/2025
RIFFER, JILL C	CENTER FOR ADV PROF STUDIES	8 EXTENDED DAYS-STRAND LEADER	08/06/2025
RINDOM, HALLEY ANN	OXFORD MIDDLE SCHOOL	LEADERSHIP TEAM MEMBER	08/06/2025
RINEARSON, SHAUNA CHRISTINE	BLUE VALLEY SOUTHWEST HS	12 EXTENDED DAYS-DEPT CHAIR	08/06/2025
RITZEL, MICHAEL E	OAK HILL ELEMENTARY	DIRECTOR-VOCAL MUSIC	08/06/2025
ROBERTS, KENNETH LEON	BLUE VALLEY NORTH HIGH SCHOOL	ASST COACH-BOYS BASKETBALL	11/16/2025
ROBERTS, MEGAN BLOOM	BLUE VALLEY NORTHWEST HS	8 EXTENDED DAYS-LIBR MEDIA SPC	08/06/2025
ROBINSON, DANYLLE RENEE	DISTRICT WIDE	LIMITED SUPPLY 1 OF 3	09/16/2025
RODRIGUEZ, DIAMOND J'QUAY	PLEASANT RIDGE MIDDLE SCHOOL	ASST DIRECTOR-FALL PLAY	08/16/2025
ROSE, JESSICA LAUREN	LEAWOOD MIDDLE SCHOOL	4 EXTENDED DAYS-NURSE MS	08/06/2025
ROUSE, AMY K	AUBRY BEND MIDDLE SCHOOL	ASST DIRECTOR-FALL MUSICAL	08/16/2025



Human Resources Report to the Board of Education

Addendum

September 8, 2025

Administration recommends approval of the following actions:

RUDDY, JOHN MICHAEL	PLEASANT RIDGE MIDDLE SCHOOL	ASST COACH-FOOTBALL	08/16/2025
RUDDY, JOHN MICHAEL	PLEASANT RIDGE MIDDLE SCHOOL	TEAM LEADER-GRADE 8	08/06/2025
RUMBOUGH, COLLEEN M	BLUE VALLEY MIDDLE SCHOOL	17 EXTENDED DAYS-PSYCHOLOGIST	08/06/2025
RUTHERFORD-SERPE, POLLY ANNE	PLEASANT RIDGE MIDDLE SCHOOL	ASST DIRECTOR-FALL PLAY	08/16/2025
SAGESER, SYDNEY LEIGH	OAK HILL ELEMENTARY	8 EXTENDED DAYS-LIBR MEDIA SPC	08/06/2025
SALTS, PEGGY J	WOLF SPRINGS ELEMENTARY	9 EXTENDED DAYS-COUNSELOR	08/06/2025
SAMPLE, JENNIFER D	BLUE VALLEY WEST HIGH SCHOOL	ASST COACH-BOYS SWIMMING	11/16/2025
SAMPLE, JENNIFER D	BLUE VALLEY WEST HIGH SCHOOL	ASST COACH-GIRLS SWIMMING	03/01/2026
SAMPLE, SIOBHAN MARIAH	TIMBER CREEK ELEMENTARY	16 EXTENDED DAYS-IDC	08/06/2025
SAMPLE, TOBIN JOSEPH	BLUE VALLEY WEST HIGH SCHOOL	ASST COACH-GIRLS SWIMMING	03/01/2026
SATTLER, TYLER E	BLUE VALLEY MIDDLE SCHOOL	ASST DIRECTOR-FALL PLAY	08/16/2025
SAWYER, KATHLEEN A	PLEASANT RIDGE MIDDLE SCHOOL	ASST COACH-VOLLEYBALL	08/16/2025
SCHAAKE, SHARI	BLUE VALLEY SOUTHWEST HS	11 EXTENDED DAYS-DEPT CHAIR	08/06/2025
SCHAAKE, SHARI	BLUE VALLEY SOUTHWEST HS	17 EXTENDED DAYS-COUNSELOR	08/06/2025
SCHMIDT, JACOB JOHN	AUBRY BEND MIDDLE SCHOOL	LEADERSHIP TEAM MEMBER	08/06/2025
SCHNEEBERGER, CAROL HENDERSON	ASPEN GROVE ELEMENTARY	9 EXTENDED DAYS-COUNSELOR	08/06/2025
SCHULLER, ELIZABETH JEAN	OVERLAND TRAIL MIDDLE SCHOOL	PDC REPRESENTATIVE	08/06/2025
SCHULLER, ELIZABETH JEAN	DISTRICT WIDE	PDC REPRESENTATIVE	08/06/2025
SCHUMACHER, KERI LYNN	EDUCATIONAL SUPPORT CENTER	16 EXTENDED DAYS-IDC	08/06/2025
SCHWABAUER, AMANDA NICOLE	CEDAR HILLS ELEMENTARY	8 EXTENDED DAYS-LIBR MEDIA SPC	08/06/2025
SCHWEIGER, AMANDA JO	LAKEWOOD MIDDLE SCHOOL	LEADERSHIP TEAM MEMBER	08/06/2025
SEAMAN, TIFFANY STAR	EDUCATIONAL SUPPORT CENTER	16 EXTENDED DAYS-DCT	08/06/2025
SHAH, CYNTHIA LYNN	DISTRICT WIDE	LIMITED SUPPLY 1 OF 3	09/16/2025
SHANNON, KIMBER LEE	LEAWOOD MIDDLE SCHOOL	ASST DIRECTOR-FALL MUSICAL	08/16/2025
SHANNON, KIMBER LEE	LEAWOOD MIDDLE SCHOOL	ASST DIRECTOR-SPRING PLAY	11/16/2025
SHARP, DAVID CHRISTOPHER	OVERLAND TRAIL MIDDLE SCHOOL	20 EXD ADMMIN CONSULTANT	08/06/2025
SHARTZER, ABIGAIL MARIE	DISTRICT WIDE	LIMITED SUPPLY 1 OF 3	09/16/2025
SHATZER, AMY MICHELLE	PLEASANT RIDGE MIDDLE SCHOOL	LEADERSHIP TEAM MEMBER	08/06/2025
SHAWGER, AMBRIA MAE	BLUE RIVER ELEMENTARY	17 EXTENDED DAYS-PSYCHOLOGIST	08/06/2025
SHAWGER, AMBRIA MAE	SUNRISE POINT ELEMENTARY	17 EXTENDED DAYS-PSYCHOLOGIST	08/06/2025
SHAWGER, AMBRIA MAE	DISTRICT WIDE	LIMITED SUPPLY 1 OF 3	09/16/2025
SHOEMAKER, PAIGE AMANDA	BLUE VALLEY NORTH HIGH SCHOOL	10 EXTENDED DAYS-DEPT CHAIR	08/06/2025
SIDENER, DANICIA KAILYNN	BLUE VALLEY MIDDLE SCHOOL	17 EXTENDED DAYS-COUNSELOR	08/06/2025
SIDENER, DANICIA KAILYNN	BLUE VALLEY MIDDLE SCHOOL	LEADERSHIP TEAM MEMBER	08/06/2025
SIEPERDA, TAYLOR ELAINE	BLUE VALLEY NORTHWEST HS	ASST COACH-BOYS SWIMMING	11/16/2025
SIEPERDA, TAYLOR ELAINE	VIRTUAL ED	VIRTUAL EDUCATION-FALL	08/06/2025
SIMER, KATHERINE FRANCES	HILLTOP LEARNING CENTER	10 EXTENDED DAYS-SS CONSULTANT	08/06/2025
SIMMONS, MEGAN GAY	TIMBER CREEK ELEMENTARY	DIRECTOR-CHOIR	08/06/2025
SIMMONS, MEGAN GAY	TIMBER CREEK ELEMENTARY	DIRECTOR-VOCAL MUSIC	08/06/2025
SINCLAIR-KING, CRYSTAL L	BLUE VALLEY WEST HIGH SCHOOL	SPONSOR-NATL CURRIC HONOR SOC	08/06/2025
SITES, RACHEL A	DISTRICT WIDE	LIMITED SUPPLY 1 OF 3	09/16/2025
SKAGGS, LAURA BETH	PRAIRIE STAR MIDDLE SCHOOL	LEADERSHIP TEAM MEMBER	08/06/2025
SKAGGS, LAURA BETH	PRAIRIE STAR MIDDLE SCHOOL	TEAM LEADER-SPED	08/06/2025
SKAKAL, CHELSE RENAE	BLUE VALLEY WEST HIGH SCHOOL	ASST SPONSOR-SCIENCE OLYMPIAD	08/06/2025



Human Resources Report to the Board of Education

Addendum

September 8, 2025

Administration recommends approval of the following actions:

SKAKAL, CHELSE RENAE	BLUE VALLEY WEST HIGH SCHOOL	HEAD SPONSOR-HOSA	08/06/2025
SKINKER, THOMAS K	VALLEY PARK ELEMENTARY	DIRECTOR-VOCAL MUSIC	08/06/2025
SLADE, LAUREN CAROLINE	EDUCATIONAL SUPPORT CENTER	16 EXTENDED DAYS-DCT	08/06/2025
SLICKMAN, KASSIDY ALAINE	HILLTOP LEARNING CENTER	10 EXTENDED DAYS-SS CONSULTANT	08/06/2025
SLICKMAN, KASSIDY ALAINE	DISTRICT WIDE	LIMITED SUPPLY 1 OF 3	09/16/2025
SMALL, SARAH RHEA	DISTRICT WIDE	LIMITED SUPPLY 1 OF 3	09/16/2025
SMITH, JENNIFER REBECCA	EDUCATIONAL SUPPORT CENTER	16 EXTENDED DAYS-IDC	08/06/2025
SMITH, JENNIFER REBECCA	OXFORD MIDDLE SCHOOL	LEADERSHIP TEAM MEMBER	08/06/2025
SMITH, KARA GENE	OXFORD MIDDLE SCHOOL	LEADERSHIP TEAM MEMBER	08/06/2025
SMITHYMAN, WILLIAM EDWARD	EDUCATIONAL SUPPORT CENTER	16 EXTENDED DAYS-IDC	08/06/2025
SMITHYMAN, WILLIAM EDWARD	BLUE VALLEY WEST HIGH SCHOOL	5 EXTENDED DAYS-TECH INTEG SPC	08/06/2025
SMITHYMAN, WILLIAM EDWARD	BLUE VALLEY WEST HIGH SCHOOL	6 EXTENDED DAYS-DEPT CHAIR	08/06/2025
SMITHYMAN, WILLIAM EDWARD	DISTRICT WIDE	PDC REPRESENTATIVE	08/06/2025
SPADONI, SHANNON RAE VAIL	PLEASANT RIDGE MIDDLE SCHOOL	17 EXTENDED DAYS-PSYCHOLOGIST	08/06/2025
SPAKE, GAVIN ANDREW	EDUCATIONAL SUPPORT CENTER	24 EXTENDED DAYS-DCT	08/06/2025
SPARKS, SALLY D	LAKEWOOD MIDDLE SCHOOL	LEADERSHIP TEAM MEMBER	08/06/2025
SPARKS, SALLY D	LAKEWOOD MIDDLE SCHOOL	TEAM LEADER-SPED	08/06/2025
STAINES, RYAN MICHAEL	OVERLAND TRAIL MIDDLE SCHOOL	DIRECTOR-BAND	08/06/2025
STAINES, RYAN MICHAEL	LEAWOOD MIDDLE SCHOOL	DIRECTOR-BAND	08/06/2025
STALEY, SARAH MARIE	DISTRICT WIDE	PDC REPRESENTATIVE	08/06/2025
STALLBAUMER, KRISTIN ANN	BLUE VALLEY HIGH SCHOOL	17 EXTENDED DAYS-COUNSELOR	08/06/2025
STALLBAUMER, KRISTIN ANN	BLUE VALLEY HIGH SCHOOL	4 EXTENDED DAYS-DEPT CHAIR	08/06/2025
STANFIELD, PATRICIA LEE	PLEASANT RIDGE MIDDLE SCHOOL	ASST COACH-CROSS COUNTRY	08/16/2025
STANGL, AMY COLLEEN	PRAIRIE STAR MIDDLE SCHOOL	LEADERSHIP TEAM MEMBER	08/06/2025
STANGL, AMY COLLEEN	PRAIRIE STAR MIDDLE SCHOOL	MS COORDINATOR-COMM ARTS	08/06/2025
STEENSON, EMILY MCGEE	VALLEY PARK ELEMENTARY	2 EXTENDED DAYS-NURSE ES	08/06/2025
STEINER, FAITH	BLUE VALLEY SOUTHWEST HS	ASST SPONSOR-COLOR GUARD	08/16/2025
STELTER, SHAWN M	AUBRY BEND MIDDLE SCHOOL	SPONSOR-STUDENT COUNCIL	08/06/2025
STEVENS, HANNAH J	BLUE VALLEY ACADEMY	SPONSOR-YEARBOOK	08/06/2025
STEVENSON, JAMIE M	BLUE VALLEY MIDDLE SCHOOL	ASST DIRECTOR-FALL PLAY	08/16/2025
STEVENSON, JAMIE M	BLUE VALLEY MIDDLE SCHOOL	LEADERSHIP TEAM MEMBER	08/06/2025
STEWART, KASEY MARIE	BLUE VALLEY SOUTHWEST HS	5 EXTENDED DAYS-NURSE HS	08/06/2025
STEWART, MATTHEW AARON	BLUE VALLEY WEST HIGH SCHOOL	ASST DIRECTOR-FALL PLAY	08/16/2025
STEWART, MATTHEW AARON	BLUE VALLEY WEST HIGH SCHOOL	ASST DIRECTOR-SPRING PLAY	03/01/2026
STEWART, MATTHEW AARON	BLUE VALLEY WEST HIGH SCHOOL	ASST DIRECTOR-WINTER MUSICAL	11/16/2025
STEWART, OLIVIA ROSE	LIBERTY VIEW ELEMENTARY	2 EXTENDED DAYS-NURSE ES	08/06/2025
STEWART, TAYLOR KYLE	AUBRY BEND MIDDLE SCHOOL	HEAD COACH-WRESTLING BOYS	11/16/2025
STEWART, TAYLOR KYLE	AUBRY BEND MIDDLE SCHOOL	HEAD COACH-WRESTLING GIRLS	11/16/2025
STONE, RYLIE CHRISTIAN	BLUE VALLEY WEST HIGH SCHOOL	5 EXTENDED DAYS-NURSE HS	08/06/2025
STONE, RYLIE CHRISTIAN	DISTRICT WIDE	LIMITED SUPPLY 1 OF 3	09/16/2025
STRAWDER, CRYSTAL JOY	AUBRY BEND MIDDLE SCHOOL	DIRECTOR-BAND	08/06/2025
STUEVE, ANDREW C	BLUE VALLEY NORTH HIGH SCHOOL	ASST COACH-CROSS COUNTRY	08/16/2025
STUEVE, ANDREW C	DISTRICT WIDE	LIMITED SUPPLY 1 OF 3	09/16/2025
SULLINS, JACQUELINE ANN	STILWELL ELEMENTARY	8 EXTENDED DAYS-LIBR MEDIA SPC	08/06/2025



Human Resources Report to the Board of Education

Addendum

September 8, 2025

Administration recommends approval of the following actions:

SUMMERLIN, VICTORIA MARGARET	OAK HILL ELEMENTARY	17 EXTENDED DAYS-PSYCHOLOGIST	08/06/2025
SUMMERLIN, VICTORIA MARGARET	OXFORD MIDDLE SCHOOL	17 EXTENDED DAYS-PSYCHOLOGIST	08/06/2025
SUTCLIFFE, KELLY G	HARMONY MIDDLE SCHOOL	LEADERSHIP TEAM MEMBER	08/06/2025
SWANSON, PATRICK	VIRTUAL ED	VIRTUAL EDUCATION-FALL	08/06/2025
TALLEY, SARA FELICITY	AUBRY BEND MIDDLE SCHOOL	17 EXTENDED DAYS-COUNSELOR	08/06/2025
TATE, SHELBY NICOLE	PRAIRIE STAR MIDDLE SCHOOL	ASST DIRECTOR-FALL PLAY	08/16/2025
TATE, SHELBY NICOLE	PRAIRIE STAR MIDDLE SCHOOL	LEADERSHIP TEAM MEMBER	08/06/2025
TAVERNARO, JENNIFER LYNN	LAKEWOOD MIDDLE SCHOOL	LEADERSHIP TEAM MEMBER	08/06/2025
TAVERNARO, JENNIFER LYNN	LAKEWOOD MIDDLE SCHOOL	MS COORDINATOR-COMM ARTS	08/06/2025
TAVERNARO, JENNIFER LYNN	LAKEWOOD MIDDLE SCHOOL	TEAM LEADER-GRADE 8	08/06/2025
TAYLOR, JENNIFER ELLEN	EDUCATIONAL SUPPORT CENTER	16 EXTENDED DAYS-DCT	08/06/2025
TAYLOR, KENNETH DALE	BLUE VALLEY NORTH HIGH SCHOOL	12 EXTENDED DAYS-DEPT CHAIR	08/06/2025
TAYLOR, KENNETH DALE	BLUE VALLEY NORTH HIGH SCHOOL	ASST SPONSOR-DECA/FBLA/BPA	08/06/2025
TAYLOR, LAURA KATHERINE	BLUE VALLEY WEST HIGH SCHOOL	17 EXTENDED DAYS-COUNSELOR	08/06/2025
TAYLOR, LAURA KATHERINE	BLUE VALLEY WEST HIGH SCHOOL	6 EXTENDED DAYS-DEPT CHAIR	08/06/2025
TERRELL JR, FORREST ALLEN	BLUE VALLEY HIGH SCHOOL	SUPERVISOR-GYMNASIUM	11/16/2025
TERRELL JR, FORREST ALLEN	VIRTUAL ED	VIRTUAL EDUCATION-FALL	08/06/2025
TESSON, ALEXANDRIA LAUREN	OAK HILL ELEMENTARY	16 EXTENDED DAYS-ADMIN INTERN	08/06/2025
TESSON, ALEXANDRIA LAUREN	OAK HILL ELEMENTARY	AD INTERN SUPERVISION DUTIES	08/06/2025
THOMAS, ALYSSA MAUREEN	DISTRICT WIDE	LIMITED SUPPLY 1 OF 3	09/16/2025
THOMPSON, BRITTON TANNER	BLUE VALLEY MIDDLE SCHOOL	HEAD COACH-WRESTLING BOYS	11/16/2025
THOMPSON, BRITTON TANNER	BLUE VALLEY MIDDLE SCHOOL	HEAD COACH-WRESTLING GIRLS	11/16/2025
THOMPSON, DEREK ALLEN	BLUE VALLEY WEST HIGH SCHOOL	17 EXTENDED DAYS-COUNSELOR	08/06/2025
TIFFANY, SCOTT CHANDLER	AUBRY BEND MIDDLE SCHOOL	LEADERSHIP TEAM MEMBER	08/06/2025
TODD, AMANDA WREN	BLUE VALLEY SOUTHWEST HS	17 EXTENDED DAYS-PSYCHOLOGIST	08/06/2025
TODD, AMANDA WREN	BLUE VALLEY SOUTHWEST HS	8 EXTENDED DAYS-DEPT CHAIR	08/06/2025
TOEPFER, ASHTYN LYNN	LEAWOOD MIDDLE SCHOOL	ASST DIRECTOR-FALL MUSICAL	08/16/2025
TOEPFER, ASHTYN LYNN	LEAWOOD MIDDLE SCHOOL	ASST DIRECTOR-SPRING PLAY	11/16/2025
TOMAS, ANGELA DAWN	AUBRY BEND MIDDLE SCHOOL	8 EXTENDED DAYS-LIBR MEDIA SPC	08/06/2025
TOMAS, ANGELA DAWN	AUBRY BEND MIDDLE SCHOOL	SPONSOR-STUDENT COUNCIL	08/06/2025
TORGLER, ASHLEY MEGAN	SUNRISE POINT ELEMENTARY	2 EXTENDED DAYS-NURSE ES	08/06/2025
TORRES, KATHRYN ANNE	AUBRY BEND MIDDLE SCHOOL	LEADERSHIP TEAM MEMBER	08/06/2025
TOUSLEE, GIGI SUZANNE	HARMONY MIDDLE SCHOOL	4 EXTENDED DAYS-NURSE MS	08/06/2025
TRIMBLE, MEGAN M	OXFORD MIDDLE SCHOOL	LEADERSHIP TEAM MEMBER	08/06/2025
TROUT, BRIANNE MARIE	WOLF SPRINGS ELEMENTARY	16 EXTENDED DAYS-IDC	08/06/2025
TROUTMAN, SHANNON EILEEN	STANLEY ELEMENTARY	8 EXTENDED DAYS-LIBR MEDIA SPC	08/06/2025
TSCHIRHART, STEPHANIE DENISE	AUBRY BEND MIDDLE SCHOOL	ASST COACH-VOLLEYBALL	08/16/2025
TURRENTINE, MARK WILLIAM	EDUCATIONAL SUPPORT CENTER	16 EXTENDED DAYS-DCT	08/06/2025
UFFMANN, JESSICA BETH	HARMONY ELEMENTARY	2 EXTENDED DAYS-NURSE ES	08/06/2025
VAIL, KIMBERLY SHANNON	AUBRY BEND MIDDLE SCHOOL	LEADERSHIP TEAM MEMBER	08/06/2025
VAN OORT, KARI JO	HARMONY ELEMENTARY	9 EXTENDED DAYS-COUNSELOR	08/06/2025
VAN SCOYOC, ELIZABETH ABBOTT	SERVICE CENTER	5 EXTENDED DAYS-NURSE DW	08/06/2025
VAN SCOYOC, ELIZABETH ABBOTT	BLUE VALLEY ACADEMY	5 EXTENDED DAYS-NURSE HS	08/06/2025
VAN WYHE, GABRIEL A	BLUE VALLEY SOUTHWEST HS	ASST SPONSOR-STUDENT COUNCIL	08/06/2025



Human Resources Report to the Board of Education

Addendum

September 8, 2025

Administration recommends approval of the following actions:

VAN WYHE, GABRIEL A	DISTRICT WIDE	LIMITED SUPPLY 1 OF 3	09/16/2025
VANDER FEEN, DILLON T	BLUE VALLEY SOUTHWEST HS	ASST COACH-GIRLS TENNIS	08/16/2025
VANGAASBEEK, CHRISTY IRENE	MISSION TRAIL ELEMENTARY	9 EXTENDED DAYS-COUNSELOR	08/06/2025
VANRHEENEN, DAVID K	HARMONY MIDDLE SCHOOL	17 EXTENDED DAYS-PSYCHOLOGIST	08/06/2025
VANRHEENEN, DAVID K	HARMONY ELEMENTARY	17 EXTENDED DAYS-PSYCHOLOGIST	08/06/2025
VANRHEENEN, DAVID K	HARMONY MIDDLE SCHOOL	MS COORDINATOR-INTERVENTION	08/06/2025
VATLAND, MAKENNA LYN	LIBERTY VIEW ELEMENTARY	17 EXTENDED DAYS-PSYCHOLOGIST	08/06/2025
VATLAND, MAKENNA LYN	OAK HILL ELEMENTARY	17 EXTENDED DAYS-PSYCHOLOGIST	08/06/2025
VATLAND, MAKENNA LYN	DISTRICT WIDE	LIMITED SUPPLY 1 OF 3	09/16/2025
VILLA, CAESAR	DISTRICT WIDE	LIMITED SUPPLY 1 OF 3	09/16/2025
VOOR VART, LEANN RENAE	HILLTOP LEARNING CENTER	10 EXTENDED DAYS-SS CONSULTANT	08/06/2025
VORNDRAN, DORIS IRENE	INDIAN VALLEY ELEMENTARY	2 EXTENDED DAYS-NURSE ES	08/06/2025
VOTH, ANEKA MARIE	HEARTLAND ELEMENTARY	DIRECTOR-CHOIR	08/06/2025
WAGNER, KATHERINE MARIE	SUNSET RIDGE ELEMENTARY	8 EXTENDED DAYS-LIBR MEDIA SPC	08/06/2025
WAGONER, JOEL DAVID	OVERLAND TRAIL MIDDLE SCHOOL	LEADERSHIP TEAM MEMBER	08/06/2025
WAGONER, JOEL DAVID	OVERLAND TRAIL MIDDLE SCHOOL	TEAM LEAD-EXPLORATION	08/06/2025
WALKER, AUBRIE NORINE	HILLTOP LEARNING CENTER	10 EXTENDED DAYS-SS CONSULTANT	08/06/2025
WARD, KATHARINE ELIZABETH BRIGHTON	BLUE VALLEY HIGH SCHOOL	ASST COACH-DEBATE	08/16/2025
WARNER, CORBIN LANE MCINTOSH	BLUE VALLEY HIGH SCHOOL	ASST COACH-BOYS SOCCER	08/18/2025
WARNES, TIFFANY NICOLE	BLUE VALLEY WEST HIGH SCHOOL	6 EXTENDED DAYS-DEPT CHAIR	08/06/2025
WARRICK, MANDI LYNN	LEAWOOD MIDDLE SCHOOL	17 EXTENDED DAYS-COUNSELOR	08/06/2025
WARRICK, MANDI LYNN	LEAWOOD MIDDLE SCHOOL	LEADERSHIP TEAM MEMBER	08/06/2025
WASKO, STEVEN M	SUNRISE POINT ELEMENTARY	DIRECTOR-INSTRUMENTAL MUSIC	08/06/2025
WASKO, STEVEN M	ASPEN GROVE ELEMENTARY	DIRECTOR-INSTRUMENTAL MUSIC	08/06/2025
WASKO, STEVEN M	PRAIRIE STAR MIDDLE SCHOOL	DIRECTOR-ORCHESTRA	08/06/2025
WATERS, EMILY AUTUMN	HILLTOP LEARNING CENTER	17 EXTENDED DAYS-PSYCHOLOGIST	08/06/2025
WATKINS, HALEY BROOKE	AUBRY BEND MIDDLE SCHOOL	SPONSOR-NEWSPAPER	08/06/2025
WEBER, CASEY MARGUERITE	BLUE VALLEY SOUTHWEST HS	17 EXTENDED DAYS-COUNSELOR	08/06/2025
WEBER, JENNIFER CHRISTINE	BLUE VALLEY NORTH HIGH SCHOOL	17 EXTENDED DAYS-COUNSELOR	08/06/2025
WEISS, REBECCA GASSER	DISTRICT WIDE	LIMITED SUPPLY 1 OF 3	09/16/2025
WELLS, MARY MELINDA	EDUCATIONAL SUPPORT CENTER	24 EXTENDED DAYS-DCT	08/06/2025
WENECK, LINDSAY GRANT	COTTONWOOD POINT ELEMENTARY	2 EXTENDED DAYS-NURSE ES	08/06/2025
WESTCOTT, JOHNATHON THOMAS	OXFORD MIDDLE SCHOOL	LEADERSHIP TEAM MEMBER	08/06/2025
WHALEN, JOSEPH PATRICK	DISTRICT WIDE	PDC REPRESENTATIVE	08/06/2025
WHETZEL, AARON EDWARD	LEAWOOD MIDDLE SCHOOL	ASST COACH-BOYS BASKETBALL	11/16/2025
WHITE, JOEL THOMAS	BLUE VALLEY SOUTHWEST HS	SUPERVISOR-GYMNASIUM	11/16/2025
WHITE, JOEL THOMAS	BLUE VALLEY SOUTHWEST HS	SUPERVISOR-STADIUM	08/06/2025
WHITE, PHILLIP M	PLEASANT RIDGE MIDDLE SCHOOL	LEADERSHIP TEAM MEMBER	08/06/2025
WHITLOCK, DEANNE THERESE	EDUCATIONAL SUPPORT CENTER	16 EXTENDED DAYS-IDC	08/06/2025
WIESE, AMY MICHELLE	BLUE VALLEY NORTH HIGH SCHOOL	17 EXTENDED DAYS-COUNSELOR	08/06/2025
WILCOX, BROOKE E	BLUE VALLEY WEST HIGH SCHOOL	17 EXTENDED DAYS-PSYCHOLOGIST	08/06/2025
WILCOX, BROOKE E	CEDAR HILLS ELEMENTARY	17 EXTENDED DAYS-PSYCHOLOGIST	08/06/2025
WILES, ALLISON RAE	HEARTLAND ELEMENTARY	2 EXTENDED DAYS-NURSE ES	08/06/2025
WILES, ALLISON RAE	HILLTOP LEARNING CENTER	2 EXTENDED DAYS-NURSE ES	08/06/2025



Human Resources Report to the Board of Education

Addendum

September 8, 2025

Administration recommends approval of the following actions:

WILKINSON, LESLIE JEANNE	DISTRICT WIDE	PDC REPRESENTATIVE	08/06/2025
WILLIAMS, JANELL DAWN	BLUE VALLEY WEST HIGH SCHOOL	17 EXTENDED DAYS-PSYCHOLOGIST	08/06/2025
WILLIAMS, SYLVIA LYNN	OVERLAND TRAIL MIDDLE SCHOOL	LEADERSHIP TEAM MEMBER	08/06/2025
WILLIAMS, SYLVIA LYNN	OVERLAND TRAIL MIDDLE SCHOOL	TEAM LEADER-GRADE 7	08/06/2025
WILSON, NICOLE M	OVERLAND TRAIL MIDDLE SCHOOL	LEADERSHIP TEAM MEMBER	08/06/2025
WILSON, NICOLE M	OVERLAND TRAIL MIDDLE SCHOOL	TEAM LEADER-GRADE 6	08/06/2025
WISE, DEANNA MARIE	LIBERTY VIEW ELEMENTARY	8 EXTENDED DAYS-LIBR MEDIA SPC	08/06/2025
WITTEBORG, KRISTIN MARIE	TIMBER CREEK ELEMENTARY	17 EXTENDED DAYS-PSYCHOLOGIST	08/06/2025
WITTEBORG, KRISTIN MARIE	ASPEN GROVE ELEMENTARY	17 EXTENDED DAYS-PSYCHOLOGIST	08/06/2025
WOLF, JULIE BALDWIN	LEAWOOD ELEMENTARY	2 EXTENDED DAYS-NURSE ES	08/06/2025
WOODWARD, TAYLOR NAOMI	DISTRICT WIDE	LIMITED SUPPLY 1 OF 3	09/16/2025
WOULFE, JULIE MARIE	BLUE VALLEY MIDDLE SCHOOL	ASST COACH-VOLLEYBALL	08/16/2025
WOULFE, WILLIAM RICHARD JOSEPH	BLUE VALLEY NORTHWEST HS	ASST COACH-FOOTBALL	08/16/2025
WRAY, BENJAMIN TIPTON	MISSION TRAIL ELEMENTARY	DIRECTOR-CHOIR	08/06/2025
WRAY, BENJAMIN TIPTON	MISSION TRAIL ELEMENTARY	DIRECTOR-VOCAL MUSIC	08/06/2025
WRIGHT, JEFFREY DONALD	AUBRY BEND MIDDLE SCHOOL	ASST COACH-FOOTBALL	08/16/2025
WRIGHT, KATHRYN NICOLE	INDIAN VALLEY ELEMENTARY	DIRECTOR-CHOIR	08/06/2025
WRIGHT, KATHRYN NICOLE	INDIAN VALLEY ELEMENTARY	DIRECTOR-VOCAL MUSIC	08/06/2025
YANG, JING	WOLF SPRINGS ELEMENTARY	ADDL TEACHING CI-YEAR	08/06/2025
YARNELL, JEFF E	BLUE VALLEY HIGH SCHOOL	8 EXTENDED DAYS-DEPT CHAIR	08/06/2025
YARNELL, JEFF E	BLUE VALLEY HIGH SCHOOL	ASST DIRECTOR-FALL MUSICAL	08/16/2025
YORK, LESLEY MICHELLE	DISTRICT WIDE	PDC REPRESENTATIVE	08/06/2025
YOUNG, AMY S	PRAIRIE STAR MIDDLE SCHOOL	ASST COACH-VOLLEYBALL	08/16/2025
YOUNG, AMY S	PRAIRIE STAR MIDDLE SCHOOL	LEADERSHIP TEAM MEMBER	08/06/2025
ZACHARIAH, JISA MERIN	BLUE VALLEY SOUTHWEST HS	ASST SPONSOR-SCIENCE OLYMPIAD	08/06/2025
ZHANG, HANXUAN	WOLF SPRINGS ELEMENTARY	16 EXTENDED DAYS-IDC	08/06/2025
ZHANG, HANXUAN	VALLEY PARK ELEMENTARY	16 EXTENDED DAYS-IDC	08/06/2025
ZINK, COLLEEN MICHELLE	EDUCATIONAL SUPPORT CENTER	18 EXTENDED DAYS-DYSLEXIA TRNR	08/06/2025

Blue Valley USD #229
Claims for 9/15/25

Vendor ID	Vendor Name	
066037	MCCOWNGORDON CONSTRUCTION LLC	4,581,392.59
074433	STRAUB CONSTRUCTION COMPANY IN	1,866,260.36
066869	DAKTRONICS INC	1,289,236.00
057490	TRANE USA INC	726,984.00
064307	CIRCADIA	496,302.41
067910	ENVISION TECHNOLOGY GROUP	488,021.00
074555	CERTAPRO PAINTERS OF SHAWNEE M	429,724.45
073757	US FOODS INC	415,903.33
068799	EDUPOINT EDUCATIONAL SYSTEMS L	348,445.95
072075	POWERSCHOOL GROUP LLC	321,111.18
060686	CDW-GOVERNMENT INC	256,819.00
063299	COMBES CONSTRUCTION LLC	170,983.22
072496	SECURLY INC	163,521.94
073307	HARVEST TECHNOLOGY GROUP INC	150,316.71
007946	HOLLIS & MILLER ARCHITECTS INC	149,036.67
002757	MCCONNELL & ASSOCIATES CORP	148,283.30
063926	PLUMBING BY FISHER INC	139,551.85
067074	GOODWIN PRO TURF INC	128,965.00
027190	WENGER CORPORATION	113,115.65
074235	UNIVERSAL CONSTRUCTION COMPANY	113,009.15
072542	PINNACLE STAFFING GROUP	102,274.96
069343	TEACHER'S CURRICULUM INSTITUTE	87,995.00
066974	BCI MECHANICAL INC	87,693.95
073448	SCHOOL SPECIALTY LLC	84,794.03
000397	LANKFORD ENTERPRISES INC	82,860.00
064467	B&H PHOTO VIDEO	77,677.34
066442	VIRCO INC	75,918.64
074469	AMPLIFY EDUCATION INC	58,978.40
066424	SITEONE LANDSCAPE SUPPLY LLC	58,324.84
051394	OVERHEAD DOOR	57,169.14

Blue Valley USD #229
Claims for 9/15/25

Vendor ID	Vendor Name	
066408	DLR GROUP INC A KANSAS CORPORA	55,357.75
073228	BRADY INDUSTRIES OF KANSAS LLC	53,274.97
073910	SIGNATURE LANDSCAPE LLC	49,899.50
064530	LEXIA LEARNING SYSTEMS	49,196.00
066726	KONE INC	47,251.57
050179	BSN SPORTS	46,186.98
072481	C & C PRODUCE	43,279.11
073938	CORPORATE CLEANING GROUP INC	40,431.00
073178	HON COMPANY	39,564.88
068823	SUMMIT BEHAVIORAL SERVICES	39,050.00
013450	KANSAS CITY AUDIO VISUAL INC	38,979.17
074237	SYNDEO STAFFING KANSAS CITY LL	38,524.07
071558	SYNETIC TECHNOLOGIES	38,357.00
065188	OMEGA DOOR & HARDWARE DIV OF M	37,914.71
000300	KELLER FIRE & SAFETY INC	36,263.44
071523	DELTA INNOVATIVE SERVICES INC.	34,527.56
074820	INTRADO LIFE & SAFETY INC	33,867.33
074836	OLATHE FLEET SOLUTIONS LLC	33,689.42
060681	PECKHAM GUYTON ALBERS AND VIET	32,324.71
065665	KRUGER TECHNOLOGIES INC	31,120.00
073590	JOHNSON CONTROLS FIRE PROTECTI	30,829.83
074500	AMERGIS HEALTHCARE STAFFING IN	30,756.07
074885	INFRAMAPPA INC	29,000.00
071483	HILAND DAIRY FOODS COMPANY LLC	27,318.38
074285	HELTS TURF FARMS LLC	26,736.00
066280	REINDERS INC	26,470.31
065033	PROQUEST LLC	25,595.89
071832	BEHAVIORAL HEALTH ALLIES	23,853.00
073650	FIX A FIELD LLC	23,433.00
066468	AMERICAN DIGITAL SECURITY LLC	22,584.93

Blue Valley USD #229
Claims for 9/15/25

Vendor ID	Vendor Name	
070872	UNIVERSITY OF KANSAS HOSPITAL	22,500.00
000238	KENTON BROTHERS INC	22,474.28
074372	CURRICULUM ASSOCIATES LLC	22,302.92
062203	SSI FURNISHINGS	21,704.37
072434	WASTE MANAGEMENT OF KANSAS INC	21,405.21
061545	BENCHMARK INC	21,043.89
010225	GRAINGER	20,457.33
073591	OXFORD COMPUTER GROUP WORLDWID	20,400.00
019950	PUR-O-ZONE INC	19,934.09
073759	AMERICAN PEST MANAGEMENT	19,832.50
027790	MCGRAW HILL EDUCATION INC	19,437.70
009030	FLINN SCIENTIFIC INC	18,937.68
074182	DR DEBS CENTER FOR CHILD AND F	18,500.00
073401	SOLIANT STAFFING LLC	18,168.51
062508	CONFERENCE TECHNOLOGIES INC	17,392.94
006972	BLICK ART MATERIALS LLC	17,277.22
074886	CITY WIDE FACILITY SOLUTIONS -	16,825.00
074866	LOGICALIS INC	16,819.38
073776	HUT AMERICAN GROUP LLC	16,380.00
069292	BUILDING CONTROLS & INTEGRATIO	15,945.30
050266	FAST SIGNS	15,442.07
074890	ARTS CONCEPTS-WALL DECOR STUPE	14,961.07
064186	PEPCO INC	14,880.50
064653	95 PERCENT GROUP INC	14,667.40
073711	THARP MECHANICAL LLC	14,550.00
066939	BLUE VALLEY TRACTOR	14,302.49
001123	LAKEMARY CENTER INC	14,004.00
058266	SHOW-ME LIVE EVENT PRODUCTION	13,927.40
001465	BRACKER'S GOOD EARTH CLAYS INC	13,906.35
057395	FRY-WAGNER MOVING & STORAGE	13,884.82

Blue Valley USD #229
Claims for 9/15/25

Vendor ID	Vendor Name	
074864	GRAFTON INTEGRATED HEALTH NETW	13,200.00
067033	COMMERCIAL FILTER SERVICE OF K	13,035.32
071270	FRITZ PAINTING & DRYWALL LLC	12,990.00
074894	PROCARE THERAPY	12,535.20
074851	CESO COMMUNICATIONS LLC	12,120.00
073167	FREEDOM INTERIOR SOLUTIONS LLC	11,865.73
072615	CODECOMBAT INC	11,515.00
074561	WIL FISCHER CO OF KS	11,325.17
025800	UNITED SCHOOL ADMINISTRATORS O	11,000.00
061361	UNITED REFRIGERATION INC	10,955.12
066562	CINTAS CORPORATION NO 2	10,580.21
063858	CHILDREN'S MERCY HOSPITAL	10,289.38
062501	ABLE HANDS INTERPRETING SERVIC	10,106.18
074892	IML SECURITY SUPPLY	10,066.43
069960	SUPPLEMENTAL HEALTH CARE SERVI	9,646.30
001239	CENGAGE LEARNING	9,217.50
074807	HUWAR CONSTRUCTION AND DEVELOP	9,104.74
063508	BRAINPOP	9,000.00
059516	KAW ROOFING AND SHEET METAL IN	8,145.60
066010	ROMA BAKERY	8,076.88
064100	THE RED FORCE FIRE AND SECURIT	7,949.02
072243	BLACK DOG BASS WORKS	7,824.62
074213	KC AIRWORKS LLC	7,700.00
069609	ALL POINT TRANSPORTATION LLC	7,650.66
071891	KAPITAN BAND INSTRUMENT REPAIR	7,639.00
074587	PEPSICO BEVERAGE SALES LLC	7,391.41
072889	BORDER STATES ELECTRIC SUPPLY	7,372.21
072574	TECHCYCLE SOLUTIONS LLC	7,333.50
001964	ANIXTER INC - KANSAS CITY	7,116.00
070152	SPOONBALL SPORTS LLC	6,907.00

Blue Valley USD #229
Claims for 9/15/25

Vendor ID	Vendor Name	
071931	HOLLIDAY SAND & GRAVEL COMPANY	6,834.72
053627	ASSOCIATED AIR PRODUCTS INC	6,707.60
072017	BUILDING CONTROLS AND SERVICES	6,678.58
071660	PALEN MUSIC CENTER INC	6,649.20
069524	USIC LOCATING SERVICES INC	6,292.55
060119	MOLLY HAWKINS HOUSE INC	6,254.45
056352	VALIDITY SCREENING SOLUTIONS	6,106.00
063492	SELECT MARKETING & DISTRIBUTIN	6,088.70
074403	MARKLEY STRATEGIES LLC	6,083.33
000341	J W PEPPER	5,970.04
001039	APPLE INC	5,950.00
062158	MTS CONTRACTING INC	5,935.00
074876	UNIVERSAL CHEERLEADERS ASSOCIA	5,905.50
073429	TELETRAC NAVMAN US LTD	5,665.32
067703	SCHOLASTIC CLASSROOM MAGAZINES	5,621.04
074861	EVERWAY LLC	5,416.23
072511	COACH CLIFF'S GAGA PITS LLC	5,398.00
063632	MAXIM HEALTHCARE SERVICES INC	5,386.24
058696	PIONEER ATHLETICS	5,358.00
059640	HENDERSON ENGINEERS INC	5,336.00
065862	KANSAS BUREAU OF INVESTIGATION	5,130.00
067784	FAVORITE HEALTHCARE STAFFING L	5,085.22
002019	KANSAS ASSOCIATION OF SCHOOL B	5,000.00
074877	VARSITY SPIRIT FASHIONS & SUPP	4,950.00
070004	OLATHE STRIPING	4,810.00
002460	FREESTYLE PHOTOGRAPHIC SUPPLIE	4,778.97
073613	MEDICALESHP INC	4,679.62
066782	THEATRICAL RIGHTS WORLDWIDE LL	4,675.00
072283	ADVANCED TURF SOLUTIONS, INC.	4,605.00
074495	LR CONSULTING SOLUTIONS	4,562.50

Blue Valley USD #229
Claims for 9/15/25

Vendor ID	Vendor Name	
069371	NO TEARS LEARNING INC	4,537.34
074567	HELM SERVICE	4,462.00
074476	DAIKIN TMI LLC	4,352.38
052897	GILMORE & BELL PC	4,200.00
056954	ADORAMA INC	4,077.54
068708	GLOBAL EQUIPMENT COMPANY	4,056.80
073746	FOLLETT CONTENT SOLUTIONS LLC	4,044.86
074573	A&E TREE LLC	4,000.00
063588	WALTER P MOORE & ASSOCIATES IN	3,850.00
072997	HD SUPPLY INC	3,792.79
055728	POLAR ELECTRO INC	3,754.40
070036	INDEX RESTAURANT SUPPLY	3,750.00
063407	PAPER 101	3,635.00
071843	FOLEY EQUIPMENT COMPANY	3,582.26
057740	TURF & SOIL DIAGNOSTICS INC	3,500.00
071892	ICON POOLS LLC	3,463.46
055898	ASC PUMPING EQUIPMENT INC	3,325.65
064211	ULINE INC	3,237.09
071527	GRIMCO INC	3,216.42
061757	AGILIX SOLUTIONS LLC	3,085.98
021700	SCHOOL HEALTH CORPORATION	3,080.56
067197	THE AMERICAN BOTTLING CO INC	3,039.65
072190	BELLEVUE WEST BAND BOOSTERS	3,000.00
066857	DEHAN JR, JOHN A	2,970.00
068743	MC ELECTRIC INC.	2,802.50
073564	T & C MICRO SERVICES CO	2,760.50
071719	REINTJES & HITER CO INC	2,681.93
054274	ELECTRONICS SUPPLY CO INC	2,679.70
074683	SOUND SUCCESS LLC	2,587.50
073336	DOCUSIGN INC	2,522.98

Blue Valley USD #229
Claims for 9/15/25

Vendor ID	Vendor Name	
065999	NATIONAL STUDENT CLEARINGHOUSE	2,475.00
065866	LAKESHORE LEARNING MATERIALS	2,458.57
074794	THE WRAP DOC	2,432.25
059562	HONEY WAGON	2,256.00
073472	CORNELL, DEWEY GENE	2,250.00
074901	LINEBERRY, KENNETH WESLEY	2,250.00
002540	STANION WHOLESALE ELECTRIC CO	2,207.68
054191	MEYER MUSIC COMPANY	2,198.96
002583	SHERWIN-WILLIAMS	2,171.66
060071	OFFICE DEPOT (BUSINESS SERVICE	2,127.65
074906	BRADY INDUSTRIES	2,039.20
074911	BIDNICK, EMERSON	2,000.00
066987	DISCOUNT SCHOOL SUPPLY	1,999.96
074679	OLD SCHOOL HORNS	1,966.01
073781	HOWIES ATHLETIC TAPE	1,824.12
072941	LEARNING A-Z LLC	1,755.00
072258	RUSHORDERTEES	1,737.90
072549	MARKETING TULES	1,675.00
065863	K C BOBCAT	1,609.02
061979	STEVE WEISS MUSIC INC	1,553.80
059030	SPENCER FANE BRITT AND BROWNE	1,517.00
066654	MACKIN BOOK COMPANY	1,497.10
066220	KUTA SOFTWARE LLC	1,474.00
070100	MULTIVISTA	1,420.00
074138	ATHCO ACQUISITION CORP	1,383.53
073570	KRONOS SAASHR INC	1,361.48
074914	SCHOOLSTATUS LLC	1,360.00
059421	SCHOOL NURSE SUPPLY INC	1,329.39
065919	MEDCO SUPPLY	1,325.36
052214	VOYAGER SOPRIS LEARNING INC	1,298.00

Blue Valley USD #229
Claims for 9/15/25

Vendor ID	Vendor Name	
055818	AMERICAN TIME & SIGNAL CO	1,291.15
071737	PRO'S CHOICE PRINTING INC	1,275.00
059064	BROSKI FENCE CO LLC	1,271.00
062706	SPRINT SYSTEMS OF PHOTOGRAPHY	1,270.42
068413	RMI GOLF CARTS	1,263.36
072504	VERITIV OPERATING COMPANY	1,236.00
008530	ELECTRONIC CONTRACTING COMPANY	1,225.00
002303	BLACKMORE & GLUNT INC	1,208.90
012146	INDUSTRIAL SALES COMPANY	1,198.85
069845	CENTURY MARKETING INC	1,177.20
074888	SOCCER POST	1,155.00
074819	APPROVED NETWORKS	1,151.33
028118	NATIONAL SIGN COMPANY INC	1,126.50
068762	PETERMANN STSA LLC	1,122.46
072705	STANGER INDUSTRIES INC	1,116.00
054793	CENTAR INDUSTRIES INC	1,095.00
004775	CHARLES D JONES CO INC	1,094.15
071856	WESTLAKE HARDWARE INC	1,087.69
073281	EKON-O-PAC	1,053.00
068946	CONCEPT PRODUCTS	1,038.18
069089	WALDINGER CORPORATION, THE	1,020.58
050394	CROFT TRAILER SUPPLY INC	998.84
066675	GOPHER SPORT	994.48
056910	FASTENAL COMPANY	990.81
073720	SMOOTHIE KING	972.00
069272	CHEMSEARCH DIVISION	959.80
062434	PANEL SYSTEMS PLUS INC (PSP)	950.00
000915	BLUE VALLEY FOOD SERVICE DEPT	939.03
073468	CCC SERVICES LLC	900.00
073914	PICKUP PATROL LLC	900.00

Blue Valley USD #229
Claims for 9/15/25

Vendor ID	Vendor Name	
072411	CAPSTONE	899.00
069247	LIDDLE SPORT SHOP THE	880.00
067072	GENERAL PARTS LLC	874.17
022460	ADA BADMINTON & TENNIS	862.00
061475	CRAIG HOMECARE	859.04
070089	FITZPATRICK GOLF SHOP LLC	840.00
065953	REW MATERIALS	838.66
073330	KANSAS CITY WINNELSON	836.91
070386	PRINCETON REVIEW, THE	800.00
004350	CAROLINA BIOLOGICAL SUPPLY CO	786.74
072819	KIDS DISCOVER LLC	768.00
052807	EBSCO INFORMATION SERVICES	761.05
073790	PARTS TOWN LLC	759.00
065417	ROASTERIE INC, THE	755.05
066856	HERITAGE-CRYSTAL CLEAN LLC	712.67
000159	ABBAY SIMONS CO	710.00
027200	WEST MUSIC COMPANY INC	681.60
073935	DELTAMATH SOLUTIONS INC	680.00
072383	FOUNDATION BUILDING MATERIALS	676.80
062393	BYERS GLASS AND MIRROR INC	645.00
062074	J M O'CONNOR INC	608.00
057976	COLEMAN EQUIPMENT INC	606.09
063403	SUPERIOR GRINDING LLC	604.48
066981	CRISIS PREVENTION INSTITUTE IN	600.00
002159	SOUTHEAST KANSAS EDUCATION SER	600.00
071705	ESGI LLC	598.00
068543	ESPECIAL NEEDS LLC	593.95
058705	VAN WALL EQUIPMENT INC	587.45
055746	LUCK'S MUSIC LIBRARY	553.97
050231	REALLY GOOD STUFF INC	544.86

Blue Valley USD #229
Claims for 9/15/25

Vendor ID	Vendor Name	
074613	ATHLETIC STUFF	490.00
054689	ABLENET INC	480.00
071866	POMPS TIRE SERVICE INC	478.70
063954	ASSOCIATED EQUIPMENT SALES CO	466.64
072728	HOBART SERVICE	448.75
067675	BARNES & NOBLE BOOKSELLERS INC	442.25
073127	UNITED STATES AWARDS INC	431.12
073209	LITERACY RESOURCES LLC	427.73
063141	MIDWEST EQUIPMENT COMPANY INC	417.92
073630	MODULARHOSE.COM	410.26
074902	ALFRED, DELANEY	410.00
072820	NASCO	393.44
006800	DEMCO INC	390.21
073773	E EDWARDS WORK WEAR	387.95
072445	HARVEST AV SOLUTIONS LLC	380.00
057906	O'REILLY AUTO PARTS	379.91
069226	MFAC LLC	378.80
058138	PRICE CHOPPER - QUEENS	375.76
071086	VWR FUNDING	363.95
073621	MARTIN TECHNICAL SERVICE LLC	350.00
074199	LEGACY KC LLC	340.00
071021	KIMBALL MIDWEST	316.97
061797	SMITTY'S LAWN AND GARDEN EQUIP	314.77
072900	RIVERSIDE INSIGHTS	293.06
074832	BARBOSA DE ROUSSEAU, FABIO	277.50
060383	CFM DISTRIBUTORS INC	256.00
055771	JORBAN-RISCOE ASSOCIATES INC	250.00
062459	ADAPTIVATION INC	239.00
065972	STUDIES WEEKLY	225.87
072824	MONOPRICE INC	225.09

Blue Valley USD #229
Claims for 9/15/25

Vendor ID	Vendor Name	
074913	CHORAL TRACKS LLC	225.00
001591	SUPER DUPER PUBLICATIONS	224.18
062241	SIERRA BUILDING PRODUCTS	220.80
071788	BREAKOUT INC	218.00
073913	IDN H HOFFMAN	215.97
062814	DECKER INC	215.39
065624	ABSOLUTE AWARDS INC	192.00
020425	REEVES-WIEDEMAN COMPANY	177.36
074818	JADE ALARM CO	175.00
066750	SMALLWOOD LOCK SUPPLY INC	171.23
074272	WEBSTER, SVETLANA	168.75
014530	LATHROP GPM LLP	158.31
073933	YARD LOVE KC	150.00
066062	STAPLES CONTRACT & COMMERCIAL	149.58
001558	ACADEMIC THERAPY/HIGH NOON BOO	145.60
001286	JOHNSON CONTROLS INC	141.62
001808	JOHNSTONE SUPPLY	138.12
018300	HERFF JONES INC	136.61
074668	THOU MAYEST LLC	130.00
057855	REALITYWORKS INC	128.00
072680	MICHIGAN DYSLEXIA INSTITUTE IN	106.88
074858	THE ART OF EDUCATION UNIVERSIT	99.00
053102	SOUTHWEST STRINGS	98.60
074184	VENTRIS LEARNING LLC	90.00
073939	CARQUEST AUTO PARTS	82.56
073259	CONTROL DEPOT INC	59.19
073665	PITSCO EDUCATION LLC	58.22
057213	RIDDELL ALL AMERICAN	49.95
073157	UNIFIRST CORPORATION	47.16
074530	KANG, JIHYUN	43.75

Blue Valley USD #229
Claims for 9/15/25

Vendor ID	Vendor Name	
065263	PORTELA-WYNDRUM, WANDA	37.50
069585	KANSAS ASSOCIATION OF SCHOLARS	30.00
056663	UNITED ART AND EDUCATION INC	27.77
067336	KC STRINGS INC	24.00
068850	REJIS COMMISSION	16.00
070193	PROPIO LANGUAGE SERVICES	10.89
066107	ARAMARK	9.99
	GRAND TOTAL	15,575,163.83

Blue Valley USD #229
Disbursements for August 2025

Vendor ID	Vendor Name	
ACH	INTERNAL REVENUE SERVICE	3,305,206.04
ACH	BLUE CROSS BLUE SHIELD OF KC	3,057,025.02
063829	THOMAS MCGEE GROUP	1,584,596.87
ACH	EVERGY	1,236,870.25
ACH	KANSAS DEPT OF REVENUE	656,995.39
ACH	KPERS	428,814.23
ACH	TRANSAMERICA/DIVERSIFIED INVESTMENT	302,078.27
ACH	COMMERCE - PCARDS	262,277.33
ACH	H S A - U M B	141,012.48
ACH	DELTA DENTAL	131,404.16
ACH	WATERONE WEBPAY	111,972.96
067402	AGILE SPORTS TECHNOLOGIES	107,500.00
ACH	THOMAS McGEE - P&C	95,381.40
ACH	THE STANDARD INS - STD/LTD/SUP LIFE	71,526.87
ACH	TriSTAR - FLEX - MED/DEP REIMBURSEMENT	69,234.08
ACH	SURENCY - VISION INSURANCE	26,273.00
066424	SITEONE LANDSCAPE SUPPLY LLC	24,675.50
ACH	BVNEA	22,072.00
ACH	THOMAS McGEE - WK COMP	17,750.42
074678	BOELTER LLC	15,895.18
ACH	THE STANDARD INS - AI/HI/CI	15,508.46
ACH	BVW PTO	15,277.97
074875	AT&T ENTERPRISES LLC	15,175.28
ACH	BVNW BOOSTER CLUB	12,985.62
073929	WOODRIVER ENERGY LLC	12,712.94
ACH	BVH PTO	11,062.19
066616	SPRINGSHARE LLC	10,286.00
ACH	KPERS - WAR	8,945.25
061931	CARTER ENERGY CORP	8,591.05
068414	LIFT TRUCK SALES	8,530.81

Blue Valley USD #229
Disbursements for August 2025

Vendor ID	Vendor Name	
ACH	BVSW PTO	7,536.87
ACH	ALLSTATE - IDENTITY INSURANCE	7,108.88
ACH	KCPAY - KANSAS CHILD SUPPORT	5,472.00
ACH	KANSAS GAS SERVICE	5,019.21
ACH	PSM PTO	4,694.26
ACH	ARAG - LEGAL BENEFIT	4,394.52
ACH	LES PTO	4,376.25
ACH	OHE PTO	4,376.25
065689	NICKLAUS GOLF CLUB LP AT LIONS	3,970.00
ACH	BVEF	3,627.50
063040	ATMOS ENERGY	3,425.09
ACH	OMS PTO	2,781.35
ACH	FSPC CHILDSUPPORT - MISSOURI	2,555.00
ACH	SRE PTO	2,402.07
ACH	LMS PTO	2,487.65
065269	TAESE	2,440.00
ACH	EXECUTIVE LIFE SOLUTIONS	2,221.46
ACH	LKM PTO	2,188.12
058136	GRIFFIN, WILLIAM H	2,100.00
ACH	HMS PTO	2,086.01
ACH	STATE OF KANSAS - SALES TAX	2,045.66
ACH	HES PTO	1,969.31
068404	UNIFIED SCHOOL DISTRICT #233	1,920.00
ACH	HRT PTO	1,896.37
071385	MIDLAND PAPER	1,879.71
ACH	CITY OF KCMO - EARNINGS TAX	1,631.10
ACH	OTM PTO	1,628.94
ACH	TriSTAR SYSTEMS - ADMIN FEE	1,593.90
ACH	MOR PTO	1,556.00
072662	W H GRIFFIN TRUSTEE	1,395.00

Blue Valley USD #229
Disbursements for August 2025

Vendor ID	Vendor Name	
071089	BESSINE WALTERBACH LLP	1,341.00
013910	KSHSAA	1,308.00
ACH	AGE PTO	1,303.15
ACH	IVE PTO	1,254.52
067797	COMMERCIAL LAW GROUP PA	1,252.74
067028	EAGLES LANDING GOLF COURSE	1,230.00
073795	JOHNSON, JACQUELINE	1,223.44
068487	BVM PTO	1,215.62
ACH	ABM PTO	1,094.06
050228	JOHNSON COUNTY PARKS & RECREAT	1,012.00
ACH	WSE PTO	948.19
066616	SPRINGSHARE LLC	937.00
ACH	LKE PTO	899.56
070183	COUNTRY CLUB OF LEAWOOD	810.00
054959	BLUE VALLEY NORTHWEST HIGH	783.00
ACH	CITY OF OLATHE BILL PAY - UTILITIES	773.58
053210	VALLEY PARK ELEMENTARY PTO	716.00
ACH	OTE PTO	700.20
065429	KANSAS CITY SYMPHONY	670.00
ACH	EXPERTPAY - CA CHILD SUPPORT	656.00
073627	KANSAS MISSOURI SUPERINTENDENT	650.00
067191	KAHRS LAW OFFICES PA	625.58
067702	ST THOMAS AQUINAS HIGH SCHOOL	600.00
068767	SYCAMORE RIDGE GOLF COURSE	560.00
R01910	LINDSAY, KAMERON	504.00
068328	IRONHORSE GOLF CLUB/CITY OF LE	500.00
068820	TURNER USD 202	448.00
020979	TAYLOR, ADAM SCOTT	411.60
ACH	CPE PTO	397.75
011279	ALEXANDER, TYLER WILSON	392.00

Blue Valley USD #229
Disbursements for August 2025

Vendor ID	Vendor Name	
067599	BVSW - ONLINE FEES	387.10
064418	BVH ONLINE FEES	367.50
BVSW	BLUE VALLEY SOUTHWEST HIGH SCH	355.92
071266	KANSAS BANDMASTERS ASSOCIATION	350.00
007524	WEINSTEIN, HEATHER DANIELLE	333.95
008650	DECASTRO, AMY ANN	299.09
018703	STOCK, CARA LAURINE	287.10
074869	VRC COMPANIES LLC	282.25
005577	LATAS, ANTHONY DEAN	280.00
016858	RIZZO, CHLO-ANN A	280.00
023013	SHOMAN, ANDREW MARTIN	280.00
021448	WISEMAN, NICOLE ELIZABETH	259.55
P13284	KO, ANGELA	252.00
021499	MICHAELS, EVAN	222.00
064420	BVN ONLINE FEES	220.50
P13914	ALTMAN, TAYLOR	215.00
P13915	BARBER, JEREMY	215.00
P13734	DAVIS, ALYSSA	215.00
P13920	DE JONG, MAARTEN	215.00
P13853	GADDAM, DILEEP KUMAR	215.00
P13916	HALAWA, MAHMOUD	215.00
P13761	OKERE, CHRISTY	215.00
P13918	RIZZO, SOPHIA	215.00
P12249	SAIFAN, MARIAM	215.00
P13910	SCHULZ, ERICA	215.00
P13919	TRAMMEL, HANNA	215.00
068525	BLUE SPRINGS R-IV SCHOOL DISTR	200.00
068996	FORT SCOTT UNIFIED SCHOOL DIST	200.00
X00542	HITE, RICHARD E	200.00
068875	SHAWNEE MISSION WEST HIGH SCHO	200.00

Blue Valley USD #229
Disbursements for August 2025

Vendor ID	Vendor Name	
013811	SLOBODNIK, JACOB	200.00
ACH	BRE PTO	199.36
008008	MANN, SHERRIE ANN	198.76
021837	ROHWEDER, KATHRYN A	192.23
063577	CREDIT WORLD SERVICES INC	186.45
015162	HOGAN, NICOLE RANAE	184.48
019681	BENSCHIEDT, LAURA LOUISE	182.00
014261	TURRENTINE, MARK WILLIAM	182.00
068497	SHAWNEE MISSION NORTH	180.00
ACH	HLC PTA	175.05
067756	BONNER SPRINGS/EDWARDSVILLE SC	160.00
000126	CARR, REBECCA A	154.49
069301	EMPORIA HIGH SCHOOL	150.00
073400	KANSAS ASSOC OF SCHOOL PERSONN	150.00
063867	KSDE	150.00
068822	WASHBURN RURAL HIGH	150.00
063013	CULLIGAN OF GREATER KANSAS CIT	150.00
000630	MULLEN, STACIE ANN	149.00
P13478	DEGNAN, ANGELA	145.60
067159	SUNFLOWER HILLS GOLF COURSE	144.00
012680	LOEWEN, ETHAN LAMONT	129.00
068532	INFORMATION NETWORK OF KANSAS	120.41
067718	SMILEYS GOLF COMPLEX	120.00
052857	SPRING HILL UNIFIED SCHOOL DIS	120.00
019682	GOODEN, AUSTIN EDWARD	116.19
014458	BOX, BRIAN SAMUEL	115.50
071179	LINDE GAS & EQUIPMENT INC	113.95
013457	WESSEL, ADAM JOSEPH	112.00
008910	DELAHUNT, COLM	106.54
055267	OVERLAND PARK GOLF DIVISION	100.00

**Blue Valley USD #229
Disbursements for August 2025**

Vendor ID	Vendor Name	
010187	HOWARD, GARY LEON	98.00
071660	PALEN MUSIC CENTER INC	94.00
068737	KANSAS SPEECH COMMUNICATIONS A	90.00
017315	SATRIANO, JAMES ALAN	84.00
064422	BVW ONLINE FEES	83.30
068550	OLATHE EAST HIGH SCHOOL	80.00
014975	WARREN, ERICA MICHELLE	74.81
018868	CHAVEZ, EMMA CAITLYN	67.06
001783	ANDERSON, TERESA K	63.98
005546	DREYER, MARGO BETH	57.89
023022	STAINES, RYAN MICHAEL	57.47
074924	CLERK OF THE COURT	56.30
018254	SLADE, LAUREN CAROLINE	54.87
055409	KANSAS FOUNDATION FOR EXCELLEN	50.00
021900	HAYDEN, MERON	49.00
021618	EISSOUH, ANA	45.99
021412	LYCHE, ABIGAIL G	44.80
P09862	KITCHAIYA, PIYACHAT	40.00
054829	STERICYCLE	33.97
R01909	EUSTON, STEPHEN	32.00
022980	VOTYPKA, KELLI BETH	30.10
018372	MURRAY, LEE ANN	26.25
020943	HUGHES, DENISE LYNN	25.27
016427	HILLMAN, MELISSA D	25.13
022912	HOOVER, MALACHI LEE	25.00
020921	SAS, CONSTANTIN CATALIN	21.21
023088	MASON, KATHERINE I	19.32
017964	AYALA DE LA PAZ, EDUARDO	14.28
021445	BAKER, MADISON ANGELINA	14.28
005592	CHRISTIAN, PATRICIA M	14.00

Blue Valley USD #229
Disbursements for August 2025

Vendor ID	Vendor Name	
013642	BURNS, MELODY J	12.46
015353	MCDAVID, KATHLEEN HELEN	11.48
011591	VEGA, KIMBERLY DAWN	10.48
003980	CHYKA, MICHEAL BRUCE	9.66
009668	GIBSON, MELISSA	9.10
023041	MEYER, JASON E	6.72
016929	WESTCOTT, JOHNATHON THOMAS	6.72
022833	STILL, ANDREW ARNEZ	5.88
015822	KHAMSIHONG, MILES CHAMNONG	4.62
	GRAND TOTAL	11,919,340.86

BLUE VALLEY SCHOOLS

FINANCE AND OPERATIONS BOARD ADVISORY COMMITTEE

MINUTES

September 4, 2025 @ 7:30 a.m.

District Office Commons

FACILITATOR(S):

Jake Slobodnik, Executive Director of Operations and
Jeremy McFadden, Chief Financial Officer

COMMITTEE MEMBERSHIP:

Patrons: Elizabeth Webb, Tom Robinett, Brenda Stasiulis, Louis Pisani, Ryan Rutkowski, Megan Senatore, Cassie Banka, Stephanie Heckart, Sara Holmes, Lauren Garcia, Matthew Misch, Daniel Mayer, Stephanie James, Kelly Arvin Harrison
Board Members: Jim McMullen, Clay Norkey, Sonya Evans
Staff: Jake Slobodnik, Jeremy McFadden, Kyle Hayden, Dr. Gillan Chapman, Dr. Eric Punswick, Jason Gillam, Kaci Brutto, Carrie Myers, Brian Daley, Kelly June, Charles Rathbun

Strategic Plan Connection(s):

Empowering exemplary educators and staff – by informing decisions around compensation, staffing and operational support that promote a positive and thriving workplace.

Fostering supportive and healthy school communities – by ensuring facilities and operations contribute to safe and well-maintained environments for students and staff.

TOPIC 1

Jeremy McFadden, Chief Financial Officer, welcomed the newly appointed committee members and reviewed the agenda.

TOPIC 2

Jeremy McFadden and Dave Arteberry with Stifel Nicholas reviewed the 2025 bond sale calendar. The bond sale will be for \$101,250,000, which is the remaining bond authority from the 2023 Bond Referendum. At the October board meeting, the Board of Education will be asked to adopt a bond sale resolution authorizing the competitive bid sale on November 10th.

TOPIC 3

Dr. Eric Punswick, Chief Human Resources Officer, presented the annual human resources report. Dr. Punswick reviewed certified recruitment and retention efforts, along with historical data associated with certified staffing. The committee also discussed strategies to attract and retain staff which is a strategic plan priority.

TOPIC 4

Jason Gillam, Director of Business Operations, presented the purchasing memo as shown below.

NEXT MEETING

The next meeting will be held on October 9. The meeting adjourned at 9:00 a.m..

PURCHASES \$500,000 & ABOVE

25020 Medical Benefits RFP \$41,230,521.00 Estimated

Vendor: Blue Cross and Blue Shield of Kansas City

Location: District Wide

Anticipated Funds: Special Reserve Healthcare

Bid

BIDS

Emergency Purchase – Gym Floor repair at Blue Valley High gym \$33,210.00 Estimated

Vendor: Lankford Enterprises Inc

Location: BVH

Anticipated Funds: Capital Outlay

E-Rate FCC Form 470 Number 240015170 Network Switches	\$192,250.00
Vendor: CDW Government Inc	
Location: District Wide	
Anticipated Funding: Bond	
26008 Grass Seed	\$90,972.80 Estimated
Vendor: Grass Pad, Inc.	
Location: Grounds Department	
Anticipated Funds: Capital Outlay	
26009 Grounds Trailer	\$28,850.00
Vendor: Hoyt's Trailer Center	
Location: Grounds Department	
Anticipated Funds: Capital Outlay	
26010 Fertilizer	\$20,387.20 Estimated
Vendors: Grass Pad	\$8,075.20
Reinders	\$12,312.00
Location: Grounds Department	
Anticipated Funds: Capital Outlay	
26011 Utility Cab Tractor	\$53,600.00
Vendor: Coleman Equipment, Inc.	
Location: Grounds Department	
Anticipated Funds: Capital Outlay	
26012 Transit Vans	\$207,549.00
Vendor: Shawnee Mission Ford Inc	
Location: Facilities & Operations	
Anticipated Funds: Capital Outlay	
26013 Engineering Supplies	\$32,466.80
Vendor: Project Lead the Way Inc	
Location: Blue Valley West High School	
Anticipated Funds: Capital Outlay	

26014 3D Printers \$27,752.55
Vendor: Staples, Inc.
Location: High Schools
Anticipated Funds: Capital Outlay

COOPERATIVE PURCHASES

4J Facility Supply LLC \$35,000.00 Estimated
Purchase of yearly gym floor maintenance coat for the east half of the District.
Cooperative: TIPS #230103
Anticipated Funds: Capital Outlay

American Digital Security LLC \$28,643.49 Estimated
Purchase to add cameras to the exterior of the Hilltop Learning Center building.
Cooperative: TIPS #240101
Anticipated Funds: Bond

Brady Industries of Kansas LLC \$44,429.50
Purchase of 10 new Kaivac machines for restroom cleaning.
Cooperative: Greenbush #24.7 ESC-Facility Solutions2024
Anticipated Funds: Capital Outlay

CDW Government Inc \$83,080.00
This purchase of network equipment will support the paging replacement project in elementary schools. 26-013
Cooperative: Greenbush #022-G
Anticipated Funds: Bond

Goodwin Pro Turf Inc \$450,000.00 Estimated
Landscaping and Athletic Field Services
Cooperative: Greenbush # 25.4 ESC-lawngroundsmaint2025
Anticipated Funds: Capital Outlay

Hillyard Kansas City \$35,000.00 Estimated
Purchase of yearly gym floor maintenance coat for the west half of the District.
Cooperative: TIPS #230103
Anticipated Funds: Capital Outlay

Hon Company \$32,899.20
Purchase of chairs for District office staff.
Cooperative: Omnia Partners #R240117
Anticipated Funds: Bond

Wenger Corporation \$21,799.33
Purchase of handicap ramp for stages used at all facilities.
Cooperative: Omnia Partners #R240120
Anticipated Funds: Capital Outlay

SERVICE PURCHASES

Accruent LLC
2024/2025 2025/2026 – 2028/2029
N/A \$100,253.50 Estimated

This purchase is to move EMS software from a local server supported license to a cloud license to allow for access to EMS across all computer platforms across the district. We have currently paid \$24,450.44 for our EMS enterprise, District maintenance and EMS room sign term licenses that will be credited against the three-year commitment of \$100,253.50. Our net incremental cost over the three-year commitment, if we factor in expected increases in the current platform at the rate we have seen each year over the last three-year renewals, is \$19,322.55. After migration all district platforms, MAC and PC will have access to EMS systems, maintenance will reside at Accruent (it is currently on site with periodic Accruent visits), and Microsoft TEAMS and EMS room sign licenses will synchronize.

Year 1: \$32,870.00
Year 2: \$32,870.00
Year 3: \$34,513.50
Total: \$100,253.50
Funds: General Fund

Behavioral Health Allies

2024/2025

2025/2026

N/A

\$207,120.00 Estimated

Student (AT) will be transported to Behavioral Health Allies Academy from their home, and student (AM) will be transported from Behavioral Health Allies to KVC Academy.

Funds: SPED

Behavioral Health Allies

2024/2025

2025/2026

N/A

\$97,000.00 Estimated

Student (AT) will attend private school at Behavioral Health Allies Academy based on an IEP decision.

Funds: SPED

The Brighthouse Academy LLC

2024/2025

2025/2026

N/A

\$99,000.00 Estimated

Student (BF) will attend Brighthouse Academy for the 25-26 school year. This is an IEP decision.

Funds: SPED

Page 155

City of Overland Park

2024/2025

2025/2026

N/A

\$0.00

This agreement is between Blue Valley School District and the City of Overland Park to dedicate a temporary construction easement to the City. This easement is required for the new middle school project.

Funds: N/A

City of Overland Park

<u>2024/2025</u>	<u>2025/2026</u>
------------------	------------------

N/A	\$0.00
-----	--------

This agreement is between Blue Valley School District and the City of Overland Park to dedicate a private water service line easement to the water utility company, WaterOne. This easement is related to the expansion of the Blue Valley Recreation Activity Center.

Funds: N/A

Fix a Field LLC

<u>2024/2025</u>	<u>2025/2026</u>
------------------	------------------

N/A	\$40,000.00 Estimated
-----	-----------------------

Playground/Athletic Field Turf Repairs and Cleaning – District wide.

Playground (account 23990)	\$20,000.00
----------------------------	-------------

Athletic Fields (account 23901)	\$20,000.00
---------------------------------	-------------

Funds: Capital Outlay

Interpreting Solutions LLC

<u>2024/2025</u>	<u>2025/2026</u>
------------------	------------------

N/A	\$80,000.00 Estimated
-----	-----------------------

Contracted Level 4 ASL interpreting services for student GM at BVM.

Funds: SPED

Johnson County Community College

<u>2024/2025</u>	<u>2025/2026</u>
------------------	------------------

\$310,088.68	\$450,000.00
--------------	--------------

This is an extension of the MOU for our Career Ready Partnership with Johnson County Community College.

This partnership allows high school juniors and seniors to attend courses at JCCC.

Funds: Career & Technical Education

Maxim Healthcare Services Inc

<u>2024/2025</u>	<u>2025/2026</u>
------------------	------------------

N/A	\$72,000.00 Estimated
-----	-----------------------

This is for an LPN to provide nursing services for student (AW) at ACCESS.

Funds: SPED

Maxim Healthcare Services Inc

2024/2025

2025/2026

N/A

\$76,000.00 Estimated

A nurse (RN) is needed to provide services for a student (BB) at BVN.

Funds: SPED

Niles Home for Children

2024/2025

2025/2026

N/A

\$44,100.00 Estimated

Student (AM) attending KVC Academy for the 25-26 school year per IEP decision.

Funds: SPED

ProCare Therapy

2024/2025

2025/2026

N/A

\$40,000.00 Estimated

Para staffing support to fill a vacancy at BVM for the 25-26 school year.

Funds: SPED

ProCare Therapy

2024/2025

2025/2026

N/A

\$40,000.00 Estimated

Para to fill a vacancy at BRE for the 25-26 school year.

Funds: SPED

ProCare Therapy

2024/2025

2025/2026

N/A

\$40,000.00 Estimated

Para to fill a vacancy at OTM for the 25-26 school year.

Funds: SPED

ProCare Therapy

2024/2025

2025/2026

N/A

\$40,000.00 Estimated

A para floater to fill a vacancy for the 2025-26 school year.

Funds: SPED

SoftwareIDM Inc

<u>2024/2025</u>	<u>2025/2026</u>
\$45,000.00	\$45,000.00

Microsoft Active Directory Enterprise license Subscription. The software takes accounts from Synergy and BPlus and creates them in Office 365, Google, Active Directory, etc.

Funds: Capital Outlay

Southwest Airlines Co / Varsity Spirit

<u>2024/2025</u>	<u>2025/2026</u>
N/A	\$56,625.00 Estimated

Nationals Dance Competition Trip February 2/12-2/17/2026 in Orlando, FL. Additional expenses include \$3,500 for ground transportation. Fundraising efforts and individual family contributions will pay for this trip.

Air Travel – Southwest Airlines \$24,125

Registration/Lodging – Varsity Spirit \$32,500

Funds: Activity Funds

Southwest Airlines Co / Means Transportation /
Walt Disney World / FAME

<u>2024/2025</u>	<u>2025/2026</u>
N/A	\$133,281.95 Estimated

BVHS choir travel for show choir competition and performance at Walt Disney World. Total Travel cost anticipated at \$133,581.95. Families will be responsible for the cost of their students. If fundraising can be done, the cost will be lowered. School personnel travel cost will be wrapped into each of the 75 students' cost. This is NOT a required trip. Optional only.

Southwest Airlines \$34,000

Means Transportation \$12,750

Walt Disney World (lodging) \$35,429.70

Walt Disney World (park tickets) \$39,852.25

FAME (show choir competition host) \$11,250

Funds: Activity Funds

Supplemental Healthcare Services

2024/2025

2025/2026

N/A

\$36,000.00 Estimated

SLP services to cover for maternity leave at WSE (.4 FTE).

Funds: SPED

Validity Screening Solutions

2024/2025

2025/2026

\$39,783.50 Est.

\$38,000.00 Estimated

Validity Screening Solutions provides background screening services for the District. The District is renewing services for the 25-26 fiscal year.

Funds: Capital Outlay

RESCIND

KL Harper Holdings LLC

2024/2025

2025/2026

N/A

\$48,000.00 Estimated

Originally reported in July 2025. Staff member fell through.



Funds: SPED



September 2025 Celebrations Update

DISTRICT

All five Blue Valley high schools earned **top 10 recognition in Kansas** and placed in the **top 10% nationally** in the 2025 U.S. News and World Report's Best High Schools list.



**BLUE VALLEY HIGH SCHOOLS
RANKED TOP 10 IN KANSAS
& TOP 10% NATIONWIDE**



DISTRICT

For the seventh consecutive year, Forbes ranked Blue Valley Schools as one of the **best employers in Kansas.**

The district has been named to the list every year since the award's inception.



FORBES BEST-IN-STATE EMPLOYERS

2019 | 2020 | 2021 | 2022 | 2023 | 2024 | 2025

DISTRICT

903 Blue Valley high school students received an Advanced Placement (AP) Scholar award for tests taken during the 2024-25 school year.

The test results set new district records with 89.5% of AP exams taken receiving a score of 3 or higher, and 73.5% of Blue Valley graduates completed at least one AP course during high school.

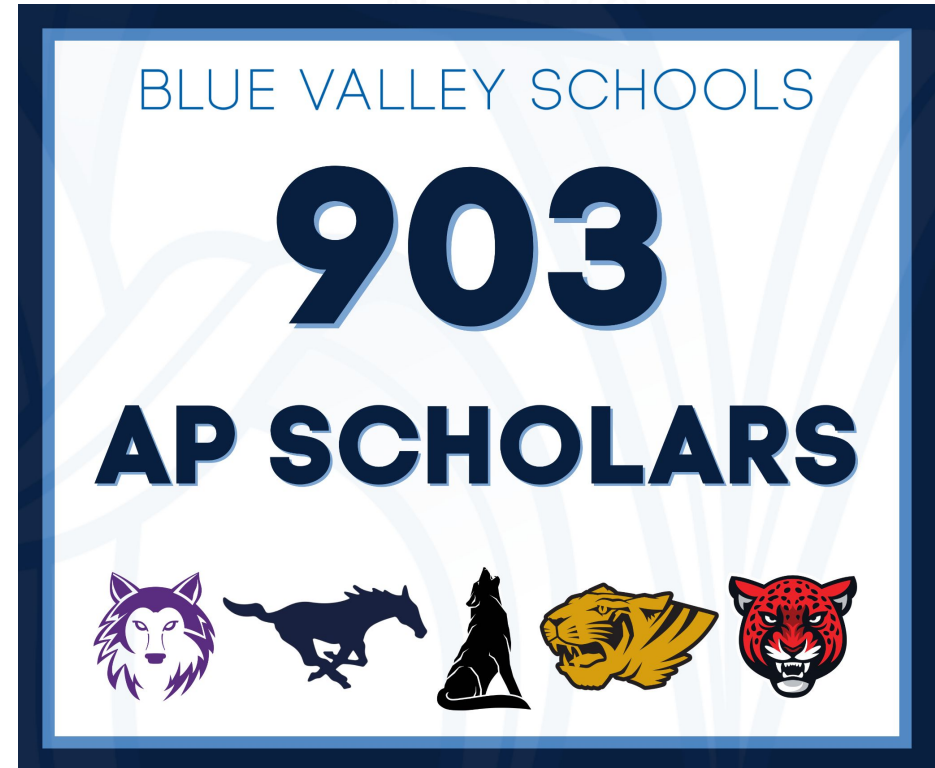

BLUE VALLEY SCHOOLS

903

AP SCHOLARS



DISTRICT

At its 35th Annual Community Breakfast this morning, the **Blue Valley Educational Foundation** celebrated 35 years of innovation, investment and impact in Blue Valley schools.



DISTRICT

September Recognition Dates & Holidays

- Suicide Prevention Month
- Hispanic Heritage Month (9/15-10/15)
- 9/1: Labor Day
- 9/7: National Grandparents Day
- 9/11: Patriot Day
- 9/15-19: National Arts in Education Week



STUDENT

Blue Valley North was named a finalist for the 2025 Kansas State High School Activities Association (KSHSAA) Performing Arts School of Excellence award.



STAFF

Blue Valley Northwest's **Todd Petersen** was selected as a recipient of the 2025 Yale Educator Award.

The recognition, presented by Yale Office of Undergraduate Admissions, honors educators from around the world who inspire and support their students to perform at high levels and achieve excellence.



STAFF

Gavin Spake, teacher at Blue Valley's Wilderness Science Center, received an Innovation & Sustainability Award from the Clay Blair Family Foundation.

The award recognizes his exceptional commitment to environmental education, innovation and sustainability.

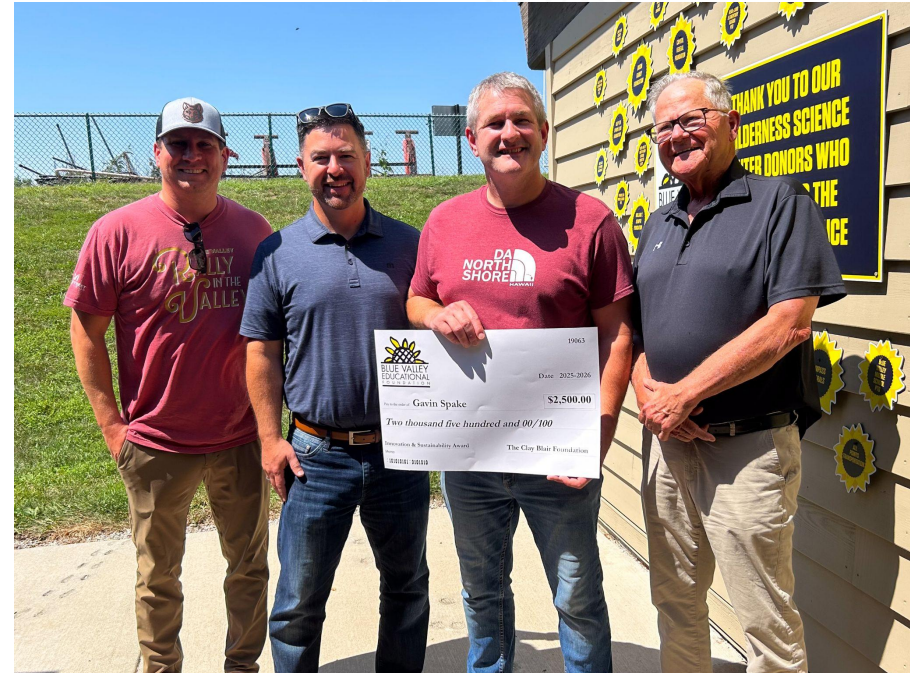

ACTIVITIES & ATHLETICS

Blue Valley Southwest's **Taylor Stanley** was named to the USA Volleyball U19 National Team and represented Team USA at the Fédération Internationale de Volleyball (FIVB) U21 World Championship.



Sports in Kansas

ALUMNI

Leanne Wong, graduate of Blue Valley High, claimed the vault national title and silver on all-around at the 2025 U.S. Gymnastics Championships.



Gerald Herbert/AP



Electric Assisted & Motorized Bikes/Scooters

Board of Education
September 8, 2025

A Trend Beyond Blue Valley

- **American Academy of Orthopaedic Surgeons** warns of **hidden dangers of E-Bikes** with rising injuries for riders of all ages.
- **U.S. Consumer Product Safety Commission** data indicates year over year **increases in injuries and deaths since 2017**.
- **USA Today** pointed out that scooters and e-bikes are the **newest travel hazard cities didn't see coming**
- A **National Public Radio report** suggested e-bike injuries have surged **sending thousands of Americans to hospitals**



Current Regulations

State/Local Laws for E-Bikes/Scooters



12.04.135 Electric-Assisted Bicycles and Electric-Assisted Scooters, Traffic Law Application

- A. May be operated on sidewalks.
- B. Traffic regulations applicable to bicycles shall apply to electric-assisted scooters and electric-assisted bicycles.
- C. May not operate an electric-assisted scooter at a speed in excess of fifteen (15) miles per hour.
- D. May not operate an electric-assisted bicycle at a speed in excess of twenty (20) miles per hour.
- E. May be operated on city streets with a speed limit up to and including 35mph.
- F. May not operate either on any interstate highway, federal or state highway within the city; provided that, nothing in this section shall prohibit either from crossing a federal or state highway.
- G. May not operate an electric-assisted bicycle or electric-assisted scooter on a street with a posted speed limit greater than thirty-five (35) miles per hour.

State/Local Laws for Motorized Bicycles



12.04.134 Application of 12.04.127 to 12.04.133 to Motorized Bicycles

- A. May be operated on sidewalks while under ONLY human power.
- B. Traffic regulations applicable to bicycles shall apply to motorized bicycles.
- C. May be operated on roadways of less than four (4) lanes with a speed limit of up to and including 35mph.
- D. May be operated on roadways of four (4) or more lanes with a speed limit of up to and including 45mph.
- E. Have a maximum designed speed of no more than 30 mph.
- F. Insurance required (OPMC 12.04.134).
- G. Operators under age 18 must wear a regulation-compliant helmet (OPMC 12.04.142).

District Impact & Trends

- Neighborhood reports of concern
- Supervision of children
- Accidents
- Property Damage
- Customization increasing risks



2024 - 2025 Observations

- Increase in number of motorized scooters and electric bikes on our campuses
 - Bus transportation changes for middle school and high school may be adding to this increase
- Increasing concerns for student safety among riders
- Difficulty for principals monitoring and enforcing a “power off and walk” guideline on campuses
- Challenges managing shared campus concerns with different arrival and dismissal schedules
- Increased property destruction on playgrounds and campuses with motorized scooters and electric bikes
- Increased concerns about students/children with unsafe riding in all areas of the community—main streets, shopping centers, etc.



Mitigating Risks



New This Year

- ❖ Strategic communication
 - Elementary and Middle School Family Newsletters
 - Video
- ❖ Student Permit Agreement
 - Partnership with families to review guidelines
 - Focusing on safety
 - Permit #
- ❖ Partnership with law enforcement topic specific



Permit # _____
(To be added by school)

Motorized and Electric Assisted Bicycles and Scooters

Student Permit Agreement



Student First Name _____ Student Last Name _____
School Name _____ Grade Level _____
Parent/Guardian First Name _____ Last Name _____
Bike/Scooter Brand _____ Color _____

1. Students who ride an electric or motorized bike/scooter to school must turn off the motor once on district property, dismount and, using clearly marked crosswalks, walk the bike/scooter to the bike rack.
2. Students are prohibited from riding electric or motorized bikes/scooters on any Blue Valley hard or soft surface playgrounds, tracks or playing fields at any time.
3. Students who intentionally damage Blue Valley School District property may be held financially responsible for repairs and criminally responsible for their actions.
4. Parents/guardians of students who operate an electric or motorized bike/scooter may be held financially liable for any damage to Blue Valley School District property caused by their student.
5. A permit sticker must be displayed on all motorized and electric assisted bicycles and scooters while on any Blue Valley campus.

The information I have submitted above is accurate and true to the best of my knowledge. I understand this agreement is intended to help keep me and others safe. I have read and understand the terms of this agreement. I agree to abide by the terms of this agreement and operate my bike/scooter in a safe manner.

Student Signature _____ Date _____
Parent/Guardian Signature _____ Date _____



Questions?





Safety & Security

**Board of Education
Sept. 8, 2025**

Strategic Approach to Safety & Security

- Relationships
- Layered approach to eliminating risk
- Partnerships:
 - Blue Valley Officers & School Resource Officers
 - Overland Park Police Department
 - Leawood Police Department
 - Children's Mercy Hospital
 - Johnson County Mental Health & other providers

Emergency Planning

- Implementation of physical, procedural, and cultural measures
 - ◆ Does it solve a current problem?
 - ◆ Is the solution based on historical data?
 - ◆ Does it address a problem likely to surface?
 - ◆ How does it impact the culture?
 - ◆ What are the unintended consequences?

Results

- Secure buildings with limited, monitored access
- Ongoing threat assessment training
- Interior thumb-turn locks on classrooms
- TIPS App for Teens
- CrisisAlert
 - ◆ Upgrades & severe weather alert
- Strategically placed intruder-resistant glazing
- 25 full time police officers
- AED expansion
- Safety drills
- Door monitoring system
- Turf playgrounds with motion lighting

QUESTIONS?

Notice of Hearing 2025-2026 Budget

The governing body of Unified School District 229 will meet on the 8th day of September 2025 at 5:35 PM at 15020 Metcalf Ave, Overland Park, KS 66223 for the purpose of hearing and answering objections of taxpayers relating to the proposed use of all funds and the amount of tax to be levied. Detailed budget information, including budget profile, building needs assessment and Board state assessments review is available at the USD 229 District Office, on the district website, and will be available at this hearing.

The Amount of 2025 Tax to be Levied and Expenditures (published below) establish the maximum limits of the 2025-2026 Budget. The 'Est. Tax Rate' (column 7), shown for comparative purposes, is subject to slight change depending on final assessed valuation.

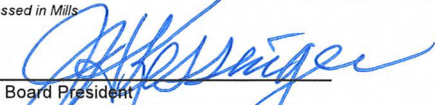
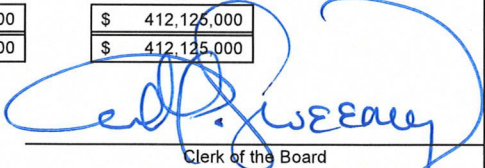
	Code 99 Line	2023-2024 Actual		2024-2025 Actual		2025-2026 Proposed Budget		
		Actual Expenditures (1)	Actual Tax Rate* (2)	Actual Expenditures (3)	Actual Tax Rate* (4)	Budgeted Expenditures (5)	Amount of 2025 Tax to be Levied (6)	Est. Tax Rate* (7)
OPERATING								
General	06	\$ 169,054,909	20.000	\$ 184,124,073	20.000	\$ 193,979,607	\$ 88,019,463	20.000
Supplemental General (LOB)	08	56,213,261	12.190	61,362,859	12.372	64,631,925	61,643,107	12.980
SPECIAL REVENUE								
Federal Funds	07	3,874,309		938,354		1,257,072		
At-Risk Education Fund	13	7,607,931		8,200,406		9,419,374		
Bilingual Education	14	2,541,784		3,193,296		4,551,647		
Virtual Education	15	711,002		756,265		1,272,223		
Capital Outlay	16	37,254,533	7.969	39,937,915	8.000	52,797,080	38,207,531	8.000
Food Service	24	11,751,125		11,345,450		14,900,000		
Professional Development	26	774,318		834,505		1,362,537		
Parent Education Program	28	873,560		878,776		1,218,381		
Summer School	29	153,072		170,899		285,709		
Special Education	30	64,252,831		72,491,921		90,247,154		
Cost of Living	33	11,046,249	2.471	12,457,450	2.639	13,901,978	12,615,413	2.656
Career and Postsecondary Education	34	5,263,643		5,322,266		1,845,000		
Gifts and Grants	35	1,898,883		1,716,064		3,222,188		
Special Liability Expense Fund	42	1,038,722	0.092	1,500,000	0.038	1,325,000	1,526,161	0.321
Extraordinary Growth Facilities	45	4,367,003	0.969	3,312,404	0.695	2,981,164	2,504,242	0.527
Special Reserve Fund	47	31,770,467		34,445,203				
KPERS Special Retirement Contribution	51	24,035,997		24,458,242		30,083,638		
Contingency Reserve	53	-		5,350,000				
Textbook & Student Material Revolving	55	3,822,130		5,018,611				
Activity Fund	56	624,188		418,248				
DEBT SERVICE								
Bond and Interest #1	62	43,144,838	9.973	54,155,738	9.707	57,067,813	42,818,161	9.016
Special Assessment	67	714,439	0.094	709,818	0.145	750,000	446,122	0.094
TOTAL USD EXPENDITURES	100	482,789,194	53.758	533,098,763	53.596	547,099,490	247,780,200	53.594
Less: Transfers	105	119,878,856		130,166,816		90,401,142		
NET USD EXPENDITURES	110	362,910,338		402,931,947		456,698,348		
TOTAL USD TAXES LEVIED	115	227,424,285		237,774,356		247,780,200		
OTHER								
Recreation Commission	84	18,964,833	2.453	20,261,063	2.405	23,189,278	11,636,165	2.450
Rec Comm Emp Benefits & Spec Liab	86	1,567,725	0.499	1,665,080	0.451	2,246,417	1,662,288	0.350
TOTAL OTHER	120	20,532,558	2.952	21,926,143	2.856	25,435,695	13,298,453	2.800
TOTAL TAXES LEVIED	125	\$ 240,120,302		\$ 250,823,941		\$ 261,078,653		
Assessed Valuation - General Fund	128	\$ 4,105,654,845		\$ 4,203,877,545		\$ 4,400,973,133		
Assessed Valuation - All Other Funds	130	\$ 4,298,558,410		\$ 4,567,746,411		\$ 4,749,185,142		
Assessed Valuation - Capital Outlay	129	\$ 4,317,606,543		\$ 4,594,832,843		\$ 4,775,941,393		
Outstanding Indebtedness, July 1		2023		2024		2025		
General Obligation Bonds	135	\$ 475,975,000		\$ 449,455,000		\$ 412,125,000		
TOTAL USD DEBT	155	\$ 475,975,000		\$ 449,455,000		\$ 412,125,000		
<i>*Tax Rates are expressed in Mills</i>								
								
		Board President		Clerk of the Board				

LOCAL OPTION BUDGET



Local Option Budget Authority is granted in accordance with K.S.A. 72-5143.

Sections from statute are *italicized* below.

Text in [brackets] within sections from statutes was added by School Finance for clarification.

(h) *The board of education of any school district that desires to increase its local option budget authority for the immediately succeeding school year shall submit written notice of such intent to the state board by April 1 of the current school year. The board of a school district shall not adopt a local option budget in excess of the authority stated in [this] notice.*

- The Local Option Budget Percentage form, within the LEA Forms application, will be considered the district's written notice of such intent for the upcoming school year.

Resolution to Adopt LOB Percentage

All boards of education shall adopt annually a local option budget percentage resolution. The maximum percent that may be authorized is the statewide average 32.3% unless the district has adopted a resolution to exceed the statewide average up to the maximum state prescribed percent (33%). The maximum percent that may be authorized by the resolution below **CANNOT** exceed the percent certified to KSDE on April 1st (see letter (h) above).

See Resolution to Exceed the Statewide Average Percent on page 2 for information on adopting a resolution that authorizes a percent higher than the statewide average and up to the state prescribed percent.

(b) *...The adoption of a resolution... shall require a majority vote of the members of the board. Such resolution [for the current school year] shall be effective upon adoption and shall require no other procedure, authorization or approval.*

- Below is a sample resolution form that may be used by the local board of education **at the time the budget is adopted** and retained at the district level. This resolution should accompany the certified budget to the county as well.

Unified School District No. 229, Johnson County, Kansas.

RESOLUTION

Be It Resolved that:

The above-named school board shall be authorized to make a Local Option Percentage in an amount of 33 percent for the 2025-26 school year.

CERTIFICATE

THIS IS TO CERTIFY that the above Resolution was duly adopted by the board of education of Unified School District No. 229, Johnson County, Kansas, on the 8th day of September, 2025.

Clerk of the Board of Education



AGENDA ITEM SUMMARY

Agenda Item:

Approval of the 2025-26 Legal Maximum Budget and Estimated Tax Rate.

Person Submitting Item: Jeremy McFadden, CFO

Background and Summary:

School districts must conduct an annual budget hearing prior to approving the maximum limits of the budget, the amount of tax to be levied, and an estimated tax rate. The approved budget and tax levy is due by September 20 to KSDE and by October 1 to Johnson County. School districts are required to publish notice of the budget hearing a minimum of 10 calendar days between publication and budget hearing.

Budget Source: N/A

Strategic Plan Alignment:

1. Advancing Academic Excellence & Exceptional Student Experiences – Budget allocations for effective teacher-to-pupil class ratios, program supports for performing arts, career and technical pathways, supplemental activities and athletic programs, and curriculum resources.
2. Fostering Supportive & Healthy School Communities – Budget allocations for special education, bilingual, at-risk, counselors and social workers.
3. Empowering Exemplary Educators and Staff – Budget allocations for competitive, market-aligned compensation packages and job-embedded professional development.

Recommendation:

Approve the 2025-26 Legal Maximum Budget and Estimated Tax Rate, including the approval of the Local Option Budget resolution.

BLUE VALLEY SCHOOLS

Blue Valley Unified School District No. 229

Workshop Special Board of Education Meeting

Monday, September 8, 2025, 8:00 a.m.

High Plains Conference Room, 15020 Metcalf Ave., Overland Park, KS 66223, 15020 Metcalf Ave.,
Overland Park, KS 66223

Jodie Dietz: Present
Dr. Sonya Evans: Present
Patrick Hurley: Absent
Jan Kessinger: Present
Gina Knapp: Present
Jim McMullen: Present
Clay Norkey: Present

A. OPENING ITEMS.

1. Call the meeting to order.

Board President Jan Kessinger called the meeting to order at 8:01 a.m.

2. Approve the Agenda

I move that the Board of Education approve the September 8, 2025, Special Board of Education Meeting Agenda as published. This motion, made by Gina Knapp and seconded by Jodie Dietz, Carried.

Jodie Dietz: Yea

Dr. Sonya Evans: Yea

Patrick Hurley: Absent

Jan Kessinger: Yea

Gina Knapp: Yea

Jim McMullen: Yea

Clay Norkey: Yea

Yea: 6, Nay: 0, Absent: 1

3. Review the Regular Meeting Agenda.

Superintendent Dr. Chapman reviewed the Regular Board of Education meeting agenda with the Board of Education.

B. REPORTS AND DISCUSSION ITEMS.

1. Calendar Review for Sale of Series 2025-AB Bonds.

Jeremy McFadden, CFO

Presenter: David Arteberry, Managing Director of Stifel, Nicolaus, & Company, Inc.

2. Digital Communication Update.

Presenter: Dr. Collier, Deputy Superintendent of Learning

3. Course Requirement Update.

Kelly June, Executive Director of Academic Services

Presenter: Kelly June, Executive Director of Academic Services.

4. Enter into Executive Session.

Executive Sessions are conducted in accordance with Kansas law (K.S.A. 75-4319). No binding action shall be taken during an executive session; however, action may be considered when board members return to the open session.

MOTION: I move that the Board of Education go into executive session with the Superintendent, the Board Attorney, and Deputy Superintendents, to discuss firearms, an attorney-client privileged matter, as permitted under K.S.A. 75-4319(b)(2). The Board of Education will resume the open meeting in the High Plains Room at 9:04 a.m. This motion, made by Gina Knapp and seconded by Jodie Dietz, Carried.

Jodie Dietz: Yea

Dr. Sonya Evans: Yea

Patrick Hurley: Absent

Jan Kessinger: Yea

Gina Knapp: Yea

Jim McMullen: Yea

Clay Norkey: Yea

Yea: 6, Nay: 0, Absent: 1

5. Enter into Executive Session.

Executive Sessions are conducted in accordance with Kansas law (K.S.A. 75-4319). No binding action shall be taken during an executive session; however, action may be considered when board members return to the open session.

MOTION: I move that the Board of Education go into executive session with the Superintendent, the Board Attorney, and Deputy Superintendents, to discuss Kansas Open Meetings law, an attorney-client privileged matter, as permitted under K.S.A. 75-4319(b)(2). The Board of Education will resume the open meeting in the High Plains Room at 9:33 a.m. This motion, made by Jodie Dietz and seconded by Jim McMullen, Carried.

Jodie Dietz: Yea

Dr. Sonya Evans: Yea

Patrick Hurley: Absent

Jan Kessinger: Yea

Gina Knapp: Yea

Jim McMullen: Yea

Clay Norkey: Yea

Yea: 6, Nay: 0, Absent: 1

C. CLOSING ITEMS.

1. Adjournment.

The September 8, 2025, Special Board of Education Meeting adjourned at 9:33 a.m.

BLUE VALLEY SCHOOLS

Blue Valley Unified School District No. 229

Regular Board of Education Meeting

Monday, September 8, 2025, 5:30 PM

Board of Education Room, District Office, 15020 Metcalf Ave., Overland Park, KS 66223

MISSION STATEMENT

Cultivating lifelong learners prepared to navigate their future with purpose.

A. OPENING ITEMS.

1. Pledge of Allegiance.

Hanna Ellsworth, a 4th-grade student from Timber Creek Elementary, will lead the Pledge of Allegiance.

2. Conduct the Hearing to Exceed the Revenue Neutral Tax Rate for 2025-26.

3. Conduct the Hearing for the Legal Maximum Budget and Estimated Tax Rate for 2025-26.

4. Awards and Recognitions.

Distinguished Service Award Recipient: Dana Huey is a Para 1 at Timber Creek Elementary.

Excellence in Education Award Recipient: Laura Benschmidt teaches Exploring Health Professions at CAPS.

5. Public Comments.

B. REGULAR AGENDA.

1. Call the Meeting to Order.

2. Approve the Regular Board of Education Meeting Agenda.

C. CONSENT AGENDA.

1. Approve the Consent Agenda.

Our rules of Parliamentary Procedure provide for a consent agenda listing several items for approval of the Board by a single motion. Documentation concerning these items has been provided to all Board members and the public in advance to ensure an extensive review. Items may be removed from the consent agenda at the request of any board member.

2. Approve the Meeting Minutes.

3. Approve the Cash Summary Report.

4. **Approve of Bids and Contracts.**
5. **Approve of the Human Resources Personnel Report and the Addendum.**
6. **Approve the Claims Report and the Disbursement Report.**

September 15, 2025, Claims for Payment totaling \$15,575,163.83.

August 2025 Disbursements totaling \$11,919,340.86.

There are no Special Fund Transfers for July 2025.

7. **Appoint Blue Valley Recreation Center Commissioner(s).**

Darren Dupriest will serve as the Blue Valley Recreation South Commissioner for a 4-year term commencing October 1, 2025.

8. **Appoint the Kansas Association of School Boards Delegate Assembly.**

- Jodie Dietz as the delegate
- Jan Kessinger as the alternate

D. REPORTS AND DISCUSSION ITEMS.

1. **Board of Education Reports.**

Finance and Operations Board Advisory Committee Meeting Minutes.

2. **Superintendent's Report.**

3. **Use of Powered Bicycles & Scooters Update.**

4. **School Safety Update.**

E. ACTION ITEMS.

1. **Approval of the 2025-26 Legal Maximum Budget and Estimated Tax Rate.**

F. CLOSING ITEMS.

1. **Board Comments.**
2. **Adjournment.**

2025 Bond Financing Overview

Remaining \$101,250,000
of Bonds Authorized by 2023 Election



September 4, 2025

Table of Contents	
	<u>Page</u>
Calendar of Events.....	1
Results of Recent Sales.....	2
Interest Rate Trend.....	3
Refinancing Analysis.....	4

STIFEL | Public Finance

4622 Pennsylvania Avenue, Suite 1210

Kansas City, Missouri 64112

816-203-8733

Unified School District No. 229 Johnson County, Kansas (Blue Valley) General Obligation School Bonds, Series 2025-A

Updated Calendar of Events

<i>Date</i>	<i>Activity</i>	<i>Responsible Party</i>
September		
<u>September</u>	1 Finalize financing plan	I/BC/MA
	4 Review financing plan with Finance and Operations Committee	I/MA
	8 Review financing plan at Board Workshop	--
	19 Draft resolution authorizing sale of Bonds ("Sale Resolution") distril	BC
	Draft notice of sale ("NOS") and Summary NOS distributed	BC
	Begin preliminary official statement ("POS") data collection	BC
October		
<u>October</u>	1 Schedule rating calls with Moody's and Standard & Poor's	I/BC/MA
	2 Comments due on draft Sale Resolution	I/BC/MA
	3 Final Sale Resolution forwarded to District	BC
	10 Draft POS distributed for comment	MA/BC
	Information forwarded to rating agencies	MA
	13 Board adopts Sale Resolution	I
	14 CUSIP numbers applied for	MA
	15 Comments due on Summary NOS	I/BC/MA
	16 Summary NOS forwarded to KS Register and local paper	BC
	First round of POS comments due	I/MA/BC
	Pre-rating meeting (on or before this date)	I/MA/BC
	17 Draft Bond Resolution distributed	BC
	Revised POS distributed for comments	MA/BC
	20 Rating conference calls (on or before this date)	I/MA/BC
	23 Publication of Summary NOS	--
	30 Comments due of draft Bond Resolution	I/BC/MA
	Comments due on NOS	I/BC/MA
	31 NOS forwarded to Bloomberg and The Bond Buyer	MA
	Near final Bond Resolution forwarded to District	BC
	Final Comments due on POS	I/BC/MA
November		
<u>November</u>	3 Receive ratings	I/MA
	POS distributed to potential bidders	BC/MA
	10 Bond Sale	I/BC/MA
	Final terms incorporated into Bond Resolution	BC/MA
	Final Bond Resolution forwarded to District	BC
	Board passes Bond Resolution	I
	11 Transcript assembly begins	BC
	14 Transcript completed and forwarded to Attorney General	BC
	21 Bond printing complete - Bonds forwarded to State Treasurer	BC
	Bond registration instructions to State Treasurer	--
	26 Closing arrangements distributed in writing	MA
	28 Transcript approved	--
	Bonds registered and forwarded to DTC	--
December		
<u>December</u>	3 Closing and delivery of funds	I/BC/MA

September						
S	M	T	W	R	F	S
	1	2	3	4	5	6
7	8	9	10	11	12	13
14	15	16	17	18	19	20
21	22	23	24	25	26	27
28	29	30				

October						
S	M	T	W	R	F	S
			1	2	3	4
5	6	7	8	9	10	11
12	13	14	15	16	17	18
19	20	21	22	23	24	25
26	27	28	29	30	31	

November						
S	M	T	W	R	F	S
						1
2	3	4	5	6	7	8
9	10	11	12	13	14	15
16	17	18	19	20	21	22
23	24	25	26	27	28	29
30						

December						
S	M	T	W	R	F	S
	1	2	3	4	5	6
7	8	9	10	11	12	13
14	15	16	17	18	19	20
21	22	23	24	25	26	27
28	29	30	31			

I = Issuer, USD #229
 BC = Bond Counsel, Gilmore & Bell
 MA = Municipal Advisor, Stifel Public Finance

**Unified School District No. 229
Johnson County, Kansas
(Blue Valley)**

Results of Recent New Money Bond Sales

	Series 2012-A	Series 2014-A	Series 2015-A	Series 2017-A	2020-A	Series 2022-A	Series 2023-A	Estimated Series 2025-A
Date of Sale	4/9/2012	1/13/2014	9/14/2015	11/13/2017	4/13/2020	4/11/2022	6/12/2023	11/10/2025
Par Amount of Bonds	\$47,000,000	\$61,000,000	\$92,200,000	\$91,285,031	\$125,000,000	\$61,835,000	\$150,000,000	\$101,250,000
True Interest Cost	2.68%	3.06%	2.84%	2.40%	2.14%	3.11%	3.56%	4.25%
Number of Bids	6	12	9	9	7	10	9	
Underwriting Discount*								
% of Par	0.822%	0.098%	0.155%	0.135%	0.210%	0.192%	0.182%	
\$ Amount	\$386,381	\$59,780	\$142,910	\$122,798	\$262,500	\$118,729	\$272,438	
10 Year MMD Index	1.97%	2.61%	2.23%	1.99%	1.10%	2.42%	2.59%	3.23%
Spread of TIC over (under) MMD	0.71%	0.45%	0.61%	0.41%	1.04%	0.69%	0.97%	1.02%
10 Year US Treasury	2.06%	2.84%	2.18%	2.40%	0.76%	2.79%	3.74%	4.25%
Spread of TIC over (under) UST	0.62%	0.22%	0.66%	0.00%	1.38%	0.32%	-0.18%	0.00%

* Underwriting Discount represents compensation received by the financial institution purchasing the bonds from the District. In a competitive bid process, the Underwriting Discount is included as part of the calculation of True Interest Cost.

Municipal Market Data "AAA" Bond Index Since January 2022

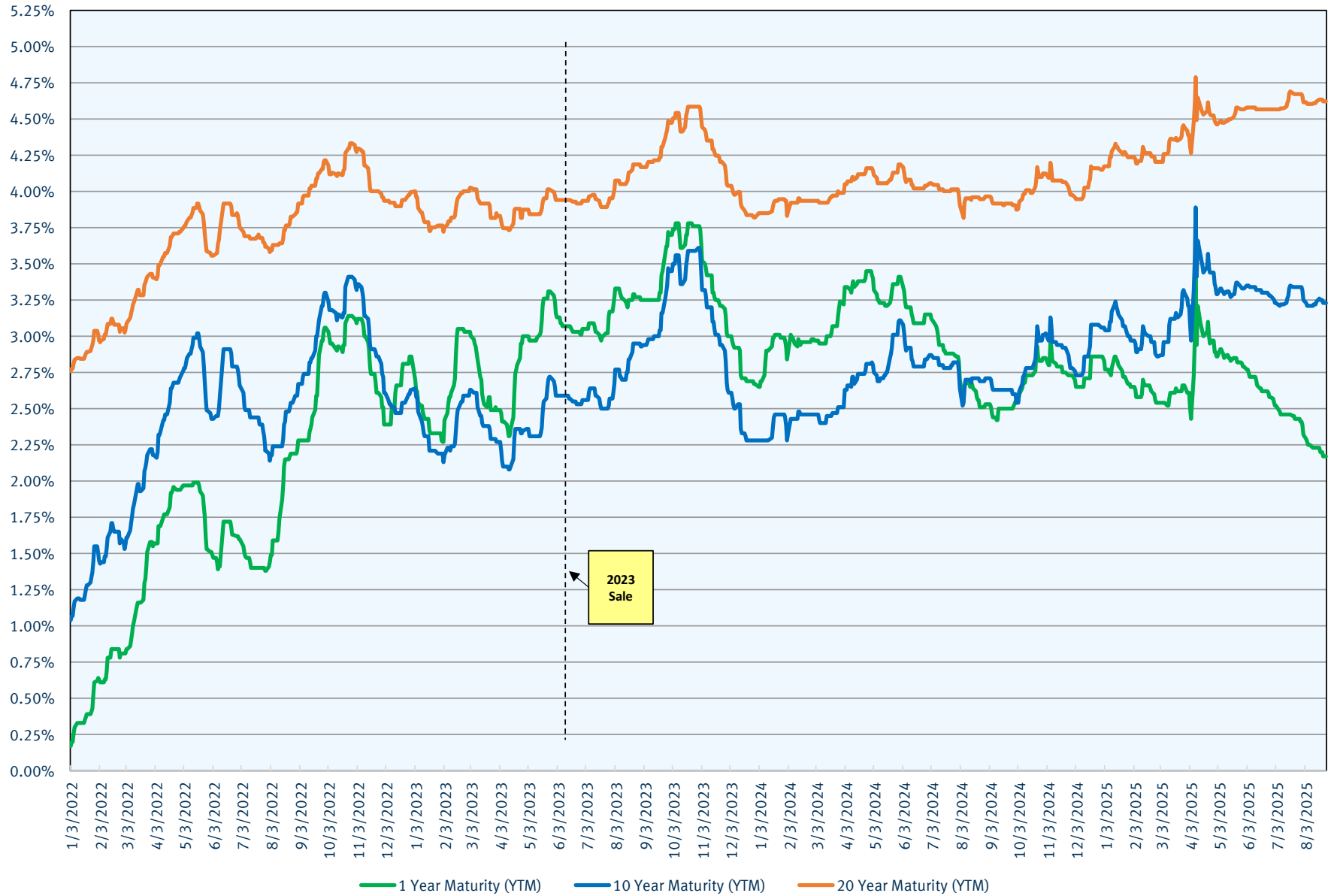

Unified School District No. 229

Johnson County, Kansas (Blue Valley)

General Obligation Refunding Bonds

Series 2025-B

Refunding Analysis - Portion of Series 2015-A

Date	Estimated Debt Service on New Bonds				Existing Debt		Savings
	Principal	Coupon	Interest	Total	Service		
2025	-	-	-	(3,401.47)	-	-	3,401.47
2026	365,000.00	2.300%	732,254.29	1,097,254.29	1,188,425.00		91,170.71
2027	475,000.00	2.350%	876,207.50	1,351,207.50	1,439,825.00		88,617.50
2028	3,990,000.00	2.350%	865,045.00	4,855,045.00	4,943,575.00		88,530.00
2029	4,120,000.00	2.400%	771,280.00	4,891,280.00	4,981,875.00		90,595.00
2030	4,290,000.00	2.500%	672,400.00	4,962,400.00	5,050,412.50		88,012.50
2031	4,475,000.00	2.700%	565,150.00	5,040,150.00	5,127,450.00		87,300.00
2032	4,660,000.00	2.900%	444,325.00	5,104,325.00	5,191,350.00		87,025.00
2033	4,820,000.00	3.050%	309,185.00	5,129,185.00	5,217,550.00		88,365.00
2034	4,990,000.00	3.250%	162,175.00	5,152,175.00	5,237,100.00		84,925.00
Total	\$32,185,000.00	-	\$5,398,021.79	\$37,579,620.32	\$38,377,562.50		\$797,942.18

Present Value Analysis Summary

Net Present Value Benefit	\$703,893.84
Net PV Benefit / \$31,745,000 Refunded Principal	2.217%

Change in Rate

Average Coupon on Refunded Bonds	3.421024%
All Inclusive Cost of New Bonds	3.002618%
Reduction in Rate	0.418407%

BLUE VALLEY
BOARD OF EDUCATION

HB 2382
FETAL DEVELOPMENT
VIDEO MANDATE



9.8.25

Kelly June

Executive Director, Academic Services

KANSAS HB 2382

FETAL DEVELOPMENT VIDEO MANDATE

“Any school district that offers any course or other instruction that addresses human growth, human development or human sexuality shall include, as part of such course or instruction, a presentation of a high-quality, computer-generated animation or high-definition ultrasound of at least three minutes in duration that shows the development of the brain, heart and other vital organs in early human fetal development.”

Johnson County districts are working together to identify:

- a common [video](#) to be used.
- a common list of courses.
- similar support materials and communication pieces.
- similar opt-out processes for families.

Once details are finalized, the video will begin to be shown this fall.

BLUE VALLEY SCHOOLS

Blue Valley Unified School District No. 229

Special Board of Education Meeting - Community Connections #1

Thursday, October 9, 2025, 6:00 PM

Board of Education Room, District Office, 15020 Metcalf Ave., Overland Park, KS 66223

Jodie Dietz: Present
Dr. Sonya Evans: Present
Patrick Hurley: Present
Jan Kessinger: Present
Gina Knapp: Present
Jim McMullen: Present
Clay Norkey: Present

A. OPENING ITEMS.

1. Call the Meeting to Order.

Board President Jan Kessinger called the meeting to order at 6:08 p.m.

2. Approve the October 9, 2025, Special Board of Education Meeting Agenda as published.

I move that the Board of Education approve the October 9, 2025, Special Board of Education Meeting agenda as published. This motion, made by Gina Knapp and seconded by Patrick Hurley, Carried.

Jodie Dietz: Yea
Dr. Sonya Evans: Yea
Patrick Hurley: Yea
Jan Kessinger: Yea
Gina Knapp: Yea
Jim McMullen: Absent
Clay Norkey: Yea

Yea: 6, Nay: 0, Absent: 1

B. DISCUSSION.

1. Community Input.

The Board of Education discussed legislative priorities.

Jim McMullen arrived at 6:30 p.m.

C. CLOSING ITEMS.

1. Adjournment.

The October 9, 2025, Special Board of Education Meeting for Community Connections adjourned at 6:45 p.m.

USD 229 Blue Valley Schools

Cash Summary

Fund #	Description	Aug 31, 2023	Aug 31, 2024	Aug 31, 2025
006	General	\$ 7,783,032	\$ 8,007,658	\$ 9,196,422
008	Supplemental General	3,072,909	3,137,480	292,988
013	At Risk	3,909,537	2,873,096	1,538,076
014	Bilingual	1,087,442	1,413,443	3,475,558
015	Virtual Education	674,056	700,455	395,763
016	Capital Outlay	3,245,834	2,525,489	(241,843)
024	Food Service	5,736,644	4,713,955	3,420,429
026	Professional Development	871,419	1,703,788	882,416
028	Parents As Teachers	409,298	619,984	312,786
029	Summer School	183,346	126,691	79,464
030	Special Education	4,739,107	3,455,381	1,736,503
033	Cost of Living	128,069	192,071	-
034	Career & Postsec Educ	787,043	1,939,441	5,148,933
042	Special Liability	331,992	680,492	(716,119)
045	Extraordinary Growth	256,543	143,151	50,727
047	Special Reserve W/C	2,000,484	3,051,211	2,287,904
048	Special Reserve Healthcare	15,146,452	15,022,116	16,096,407
051	KPERS	-	-	-
053	Contingency Reserve	20,000,000	20,250,000	14,900,000
055	Textbook & Student Materials	3,811,750	4,971,706	2,314,047
056	District Activity	327,164	(88,614)	57,330
062	Bond & Interest	67,079,818	69,353,311	61,776,848
067	Special Assessment	868,272	619,036	594,294
084	BVRC General	-	-	-
086	BVRC Empl Benefits	-	-	-
125	Title I	(1)	(258)	(4,366)
127	Title II-A	(10,406)	(1,026)	(9,492)
131	Title III	(7,006)	(5,195)	0
134	Other Federal Funds	(509,317)	(564,015)	-
135	Title VIB CEIS	-	-	-
201	Gift	837,477	867,558	795,297
202	DAC	25,453	20,365	30,794
203	BV Educational Foundation	370,881	357,497	390,191
204	SAFE School Grants	326,425	321,487	-
205	Misc Community Grants	81,963	79,457	71,202
211	Kauffman CAPS Networking	139,855	52,644	(275)
212	Mental Health Intervention Grant	-	-	(5,542)
300	College Now	-	-	-
		\$ 143,705,536	\$ 146,539,856	\$ 124,866,744

811	Bond-Capital Projects 2020	\$ 6,690,091	\$ 60,809	\$ -
812	Bond-Capital Projects 2023	148,702,103	90,236,103	(40,123,327)
		\$ 155,392,194	\$ 90,296,912	\$ (40,123,327)

TOTALS

\$ 299,097,731 \$ 236,836,768 \$ 84,743,417

Purchasing Memo

To: Finance & Operations Committee Members
From: Jason Gillam, Director of Business Operations
Jake Slobodnik, Executive Director of Operations
Date: October 9, 2025
Re: Purchases

PURCHASES \$500,000 & ABOVE

Delta Dental of Kansas Inc

2025

2026

\$1,589,014.00 Est \$1,628,495.00 Estimated

2026 Employee group dental insurance contract and renewal letter with Delta Dental of KC. 2.5% renewal increase for base and buy-up plans.

Estimated 2026 employee cost for base plan: 1,298,147.00.

Estimated 2026 employee cost for buy-up plan: 330,348.00

Funds: Employee Paid Benefit

Service Purchases

Page 6

The Standard Insurance Company

2025

2026

\$1,321,198.00 Est. \$617,857.00 Estimated

The Standard insurance policies for 2026. Cost is based upon projected participation & employee-paid premium rates for all products. Prior year cost includes short-term and long-term disability, which are reported separately for 2026. Submission of 2026 insurance policies for:

- Voluntary Group Term Life (GTL) - 2026 Est. Annual \$435,306 (Renewal)
- Accident Insurance (AI) - 2026 Est. Annual \$66,694 (Renewal)
- Hospital Insurance (HI) - 2026 Est. Annual \$65,670 (Renewal)
- Critical Illness Insurance (CI) - 2026 Est. Annual \$50,187 (Renewal)

Funds: Employee Paid

Service Purchases

Page 12

DESIGN & CONSTRUCTION PURCHASES

Blue River Elementary Playground Overlay & Restriping

\$54,370.00 Estimated

Vendor: McConnell & Associates Corp

Cooperative: TIPS #23060201

Location: BRE

Anticipated Funding: Bond

Page 14

BVNW Design and Construction Administration Services

\$132,000.00 Estimated

Vendor: KC Architects LLC

Location: BVNW

Anticipated Funding: Bond

Page 18

MLT 2602 – Painting Project

\$67,500.00 Estimated

Vendor: Hollis & Miller Architects Inc

Location: BVNW, BVM, IVE, OHE

Anticipated Funding: Capital Outlay

Page 22

STL 2501 – Site Improvements

\$471,000.00 Estimated

Vendor: Hollis & Miller Architects Inc
Location: STIL
Anticipated Funding: Bond
Page 26

BIDS

Emergency Purchase – Fiber struck

\$30,088.08

Vendor: K&W Underground
Location: ITS
Funds: Capital Outlay
Page 29

E-Rate FCC Form 470 Number 250011237 Network Equipment

\$50,905.00 Estimated

Vendor: CDW Government Inc.
Location: ITS
Funds: Bond
Page 32

26015 Compressors

\$30,568.75

Vendor: United Refrigeration Inc.
Location: BG
Funds: Capital Outlay
Page 35

26016 A/V Equipment for Wolf Springs Middle

\$304,432.52 Estimated

Vendor: Kansas City Audio Visual
Location: WSM
Funds: Bond
Page 37

26017 Forensic Supplies

\$38,301.00

Vendor: Amplyus LLC.
d/b/a MiniPCRBio
Location: BVH
Funds: Breakthrough Grant
Page 43

26018 Science Supplies

\$34,127.29

Vendors: Flinn Scientific Inc.	\$ 4,451.27
School Specialty	\$ 180.06
VWR International	\$ 1,017.72
Fisher Scientific Co.	\$12,443.88
Carolina Biological	\$15,900.86
Unimak Corp.	\$ 133.50

Location: BVH
Funds: Breakthrough Grant
Page 45

COOPERATIVE PURCHASES

Athco

\$35,305.80

Purchase of shade structure for Blue River Elementary.
Cooperative: Greenbush 24.6 ESC-PLAYGROUND-REC2024
Funds: Capital Outlay
Page 52

Brady Industries of Kansas LLC **\$65,576.00**
This purchase of two robotic scrubbers, one for Aubry Bend Middle and one for Pleasant Ridge Middle.
Cooperative: Omnia Partners #R211301
Funds: Capital Outlay
Page 54

CDW Government Inc **\$166,736.00 Estimated**
This purchase of wireless network equipment will support the new Wolf Springs Middle School. 026-013
Cooperative: Greenbush 025-F
Funds: Bond
Page 57

CDW Government Inc **\$266,545.00 Estimated**
This purchase will support the A/V projectors refresh project at the Hilltop Learning Center. 026-025
Cooperative: Greenbush 025-F
Funds: Bond
Page 62

Commercial Aquatic Services Inc **\$28,354.22**
Updating Gen 6 timing system for swim meets to Gen 7 for all pools in the district.
Cooperative: TIPS #230203
Funds: Capital Outlay
Page 65

Commercial Aquatic Services Inc **\$38,455.60**
143081-C-L CTS Backstroke Start Device Long Bracket for all pools in the district this device will help with better take off in back stroke position.
Cooperative: TIPS #230203
Funds: Capital Outlay
Page 68

Facilities Management Express LLC **\$29,404.62**
This purchase is for maintenance request, preventative maintenance, and standard dashboard software (Go FMX).
Cooperative: TIPS #220105
Funds: Capital Outlay
Page 71

Insight Global LLC **\$83,200.00 Estimated**
This will provide 2 desktop support personnel for future use if needed for a 180 Day contract.
1040 x 2 = 2080 X \$40.00 per hour for a total of \$83,200. 26-027
Cooperative: Omnia Partners 2021003051
Funds: Capital Outlay
Page 74

Ready2Go Trailer Sales LLC **\$136,734.00**
Purchase of two station restroom trailers for use at construction projects.
Cooperative: Sourcewell 092922-AGO
Funds: Capital Outlay
Page 75

Virco Inc **\$30,000.00 Estimated**
Purchase of 20 sewing machine tables for Wolf Springs Middle.
Cooperative: Omnia Partners R-TC-18004
Funds: Bond
Page 80

SERVICE PURCHASES

Allstate Identity Protection

2025

\$83,970.00 Est.

2026

\$87,173.00 Estimated

Renewal for 2026 employee paid All State Identity Protection. No rate change for 2026. Cyber protection offered to employees for personal devices. Features of cyber protection include: personal computer safety, webcam protection, firewall, antivirus, browsing and phishing protection, web filtering, VPN, password manager, and network security. 2026 renewal cost: \$10.96/employee only; \$18.96/family.

Funds: Employee Paid Benefit

Page 81

ARAG LLC

2025

\$46,649.00 Est.

2026

\$51,607.00 Estimated

ARAG Legal Insurance for 1/1/2026. One monthly rate for employee and covered dependents of \$18.78 per month. ARAG Legal insurance provides a network of attorneys for personal legal matters for employees and covered family members across a variety of needs (family, home, auto, estate planning, elder law, consumer protection, criminal situations, divorce, finance & tax, traffic & other general personal legal needs). 2026 cost: \$18.78 per month premium rate (employee and dependents). Under rate guarantee, 1/1/2025-12/31/2028. Paid for by the employee via payroll.

Funds: Employee Paid Benefit

Page 82

The Brighthouse Academy LLC

2024/2025

N/A

2025/2026

\$25,650.00 Estimated

Student (FC) will be attending Brighthouse Academy for hourly transition services (up to 10 hours/week) for the 25-26 school year. This is an IEP decision.

Funds: SPED

Page 83

The Brighthouse Academy LLC

2024/2025

N/A

2025/2026

\$25,650.00 Estimated

Student (JR) will be attending Brighthouse Academy for the remainder of the 25-26 school year. This is an IEP decision.

Funds: SPED

Page 85

CBIZ Benefits and Insurance Services Inc

2025

\$74,371.00 Est.

2026

\$78,170.00 Estimated

Voluntary retirement savings plans - 403 (b) Plan and 457(b) Plans Servicing Agreement, effective 1/1/2026. Employee paid fees via plan enrollment.

Funds: Employee Paid Benefit

Page 87

Fritz Painting & Drywall LLC

2024/2025

\$95,481.00

2025/2026

\$50,000.00 Estimated

Purchase painting services to fulfill painting needs outside of the patch and paint repair needs scope in the District.

Funds: Capital Outlay

Page 88

Research Institute for Learning and Development

2024/2025

N/A

2025/2026

\$15,750.00 Additional Est.

\$53,970.00 Revised Est. Total

Originally reported in June 2025. Purchasing 3 SMARTS CONNECT HS and 3 SMARTS CONNECT MS site licenses allows for 1 common login to access SMARTS CONNECT MS and 1 common login to access SMARTS CONNECT HS. This login is to be used by any and all MS and HS Special Education Staff in the District. The institutional licenses allow for multiple simultaneous log-ins.

Funds: SPED

Page 89

Signature Landscape LLC

2024/2025

2025/2026

N/A

\$30,000.00 Estimated

Parking lot snow removal services as needed through December 31, 2025.

Funds: Capital Outlay

Page 93

The Standard Insurance Company

2025

2026

\$356,766.00 Est.

\$430,333.00 Estimated

Submission of The Standard 2026 insurance policy for short-term disability and long-term disability.

2026 STD renewal cost \$391,502 - 23% rate increase

2026 LTD renewal cost \$38,831 - no rate increase

Funds: Special Reserve Healthcare

Page 94

Supplemental Health Care Services

2024/2025

2025/2026

N/A

\$29,000.00 Addl Est

\$65,000.00 Rev Total Est

1) SLP to cover for maternity leave at WSE 8/10-10/15/25

2) Newly added vacancy at HES from 10/17-12/19/25

Original amount: \$36,000

Increase needed: \$29,000

Total revised amount: \$65,000

Funds: SPED

Page 95

Surency Life & Health Insurance Co

2025

2026 – 2030

\$305,905.00 Est.

\$317,190.00 Estimated Annual

2026 Employee paid group vision insurance contract and renewal letter with Surency Life and Health. No rate changes

Funds: Employee Paid

Page 96

Varsity Spirit LLC / Southwest Airlines Co

2024/2025

2025/2026

\$33,388.26 Est.

\$33,000.00 Estimated

The BVN Dance Team will attend the NDA National Championships in Orlando, FL from 2/12-17/26. They will compete at the highest level of dance in the nation. Costs include room/board, meals, airfare, and ground transportation.

Estimated costs:

Varsity Spirit/National Dance Alliance (Registration/Lodging): ~\$19,700.00 (final prices have yet to be released)

Southwest Airlines: \$7,296.48

Happy Limo: \$1,500

Meals: ~\$3,000

Funds: Activity Fund

Page 99

Water District No. 1 of Johnson County

2024/2025

2025/2026

N/A

\$0.00

This agreement is between Blue Valley School District and the water utility company, WaterOne, to establish a permanent easement at Wolf Springs Middle School along 175th street for future water line development.

Funds: N/A

Page 100



AGENDA ITEM SUMMARY

Agenda Item:

Renewal of Delta Dental Insurance Contract with Delta Dental of KC
Products are employee paid.

Person Submitting Item:

Dr. Eric Punswick

Background and Summary:

2.5% renewal increase for base and buy-up plans
Estimated 2026 employee cost for base plan: 1,298,147.00
Estimated 2026 employee cost for buy-up plan: 330,348.00

Budget Source:

Employee paid

Strategic Plan Alignment:

The renewal of quality voluntary dental plans supports the strategic priority of empowering exemplary educators and staff. Strong benefits attract and retain exceptional educators; this results in greater student success. Promoting the wellbeing of employees honors the value of each staff member and engages BV, as an employer, who fosters supportive and healthy school communities.

Recommendation:

Approval of renewal of contract for Delta Dental base and buy-up plans



PURCHASING UNIVERSAL REQUEST

BLUE VALLEY SCHOOL DISTRICT #229

Department/Bldg.:	Human Resources	Requested By:	Dr. Eric Punswick
Purpose: (please explain in detail why we need the items or services requested)			
2026 Employee group dental insurance contract and renewal letter with Delta Dental of KC			
2.5% renewal increase for base and buy-up plans			
Estimated 2026 employee cost for base plan: 1,298,147.00			
Estimated 2026 employee cost for buy-up plan: 330,348.00			
Fund:	Employee paid ▼	Account Number:	
Funding Year:	2025/2026 ▼	Location(s) items or services are for:	District Wide Benefit
Does this use Bond Funds? (if yes, see below)		No ▼	
<input type="checkbox"/> This request includes extended warranty, service or maintenance. Please complete the <u>Bond Warranty Agreement Form on page 2</u>		<input type="checkbox"/> This request includes training or consultation. Please complete <u>Bond Consultant Services Form on Page 3</u>	

Check all that apply to this Purchase:

- | | |
|--|--|
| <input type="checkbox"/> This is a New Contract | <input type="checkbox"/> This is a New Bid/RFP |
| <input checked="" type="checkbox"/> This is a Renewal Contract | <input type="checkbox"/> This is a Purchase from Bid/RFP # _____ |
| <input type="checkbox"/> This is a Curriculum purchase | <input type="checkbox"/> This Purchase requires BOE Signatures |
| <input type="checkbox"/> This can be purchased off of _____ Contract # _____ | |

Begin Date: 1/1/2026	End Date: 12/31/2026
Company: Delta Dental of Kansas	Street Address: 11300 Tomahawk Creek Prkwy-St 350 ⁺
Contact Name: Erin Baker	City: Leawood
Telephone: (515) 237-0263	State: KS
Email: ebaker@deltadentalks.com	Zip Code: 66211
Cost: \$ 1,628,495.00	
Prior Year Cost: \$ 1,589,014.00	
Terms: (Annual, Multi-Year, One-Time): Annual ▼	

Month:(board meeting) October 2025 **Budget Administrator** Dr, Eric Punswick **Date**10/1/2025



Trust the Experts for Your Benefits

USD #229-BLUE VALLEY

Benefit Renewal

For the Period of 01/01/2026 to 12/31/2026

Account Executive : Erin Baker / ebaker@deltadentalks.com



USD #229-BLUE VALLEY
GROUP NUMBER: 00000001698

Fully Insured

Renewal Rates Effective: 01/01/2026 to 12/31/2026

Current Enrollment USD #229-BLUE VALLEY-BUYUP

Employee Only	198
Employee and Spouse	30
Employee and One Child	14
Employee and Children	46
Employee and Family	48
Total	336

Current Rates

Employee Only	\$45.82
Employee and Spouse	\$91.54
Employee and One Child	\$107.56
Employee and Children	\$107.56
Employee and Family	\$174.82

Renewal Rates

Employee Only	\$46.96
Employee and Spouse	\$93.82
Employee and One Child	\$110.24
Employee and Children	\$110.24
Employee and Family	\$179.18

*Delta Dental of Kansas reserves the right to revise the annual rates should the group request changes in their benefits, networks, service levels or subscriber locations. Annual rates may also be changed if the total enrollment, enrollment distribution by product, enrollment tier or employee locations differ by 10% or more from the current enrollment noted in this document. We also reserve the right to re-evaluate the rates in the event of updated government regulations for the dental industry.

STATEMENT OF CONFIDENTIALITY

The information contained in this document is the property of Delta Dental of Kansas and may not be disclosed except to employees or duly authorized agents of USD #229-BLUE VALLEY without express written permission from Delta Dental of Kansas.



USD #229-BLUE VALLEY
GROUP NUMBER: 00000001698

Fully Insured

Renewal Rates Effective: 01/01/2026 to 12/31/2026

Current Enrollment	USD #229-BLUE VALLEY-BASE
Employee Only	1346
Employee and Spouse	157
Employee and One Child	98
Employee and Children	186
Employee and Family	176
Total	1963

Current Rates

Employee Only	\$35.62
Employee and Spouse	\$69.36
Employee and One Child	\$81.46
Employee and Children	\$81.46
Employee and Family	\$132.36

Renewal Rates

Employee Only	\$36.50
Employee and Spouse	\$71.08
Employee and One Child	\$83.50
Employee and Children	\$83.50
Employee and Family	\$135.66

*Delta Dental of Kansas reserves the right to revise the annual rates should the group request changes in their benefits, networks, service levels or subscriber locations. Annual rates may also be changed if the total enrollment, enrollment distribution by product, enrollment tier or employee locations differ by 10% or more from the current enrollment noted in this document. We also reserve the right to re-evaluate the rates in the event of updated government regulations for the dental industry.

STATEMENT OF CONFIDENTIALITY

The information contained in this document is the property of Delta Dental of Kansas and may not be disclosed except to employees or duly authorized agents of USD #229-BLUE VALLEY without express written permission from Delta Dental of Kansas.



USD #229-BLUE VALLEY
 GROUP NUMBER: 0000001698
 Fully Insured

Renewal Rates Effective: 01/01/2026 to 12/31/2026

USD #229-BLUE VALLEY

1. Current Enrollment	2299
2. Average Enrollment	2222
Experience Period: 03/01/2024 to 02/28/2025	
3. Paid Premium	\$1,518,703.00
4. Paid Claims	\$1,349,010.00
Trend 1.1515	
5. Required Retention	\$151,870.30
(includes taxes and administration costs)	
6. Commission	\$0.00
7. Total Loss Ratio	116.81%
8. Final Rate Adjustment	2.5%
<ul style="list-style-type: none"> • New 1st of 2 yr contract with 5% cap per '27 	

*Delta Dental of Kansas reserves the right to revise the annual rates should the group request changes in their benefits, networks, service levels or subscriber locations. Annual rates may also be changed if the total enrollment, enrollment distribution by product, enrollment tier or employee locations differ by 10% or more from the current enrollment noted in this document. We also reserve the right to re-evaluate the rates in the event of updated government regulations for the dental industry.

STATEMENT OF CONFIDENTIALITY

The information contained in this document is the property of Delta Dental of Kansas and may not be disclosed except to employees or duly authorized agents of USD #229-BLUE VALLEY without express written permission from Delta Dental of Kansas.



AGENDA ITEM SUMMARY

Agenda Item:

Renewal of voluntary employee paid benefits including life, accident, hospital indemnity, and critical illness insurance through The Standard Insurance Company.

Person Submitting Item:

Dr. Eric Punswick

Background and Summary:

Submission of 2026 insurance policies for:
Voluntary Group Term Life (GTL) - 2026 Est. Annual \$435,306 (Renewal)
Accident Insurance (AI) - 2026 Est. Annual \$66,694 (Renewal)
Hospital Insurance (HI) - 2026 Est. Annual \$65,670 (Renewal)
Critical Illness Insurance (CI) - 2026 Est. Annual \$50,187 (Renewal)

Budget Source:

Employee paid

Strategic Plan Alignment:

The renewal of quality medical plans supports the strategic priority of empowering exemplary educators and staff. Strong benefits attract and retain exceptional educators; this results in greater student success. Promoting the wellbeing of employees honors the value of each staff member and engages BV, as an employer, who fosters supportive and healthy school communities.

Recommendation:

Approve the renewal of voluntary benefit plans for employees through The Standard Insurance company.



PURCHASING UNIVERSAL REQUEST

BLUE VALLEY SCHOOL DISTRICT #229

Department/Bldg.:	Human Resources	Requested By:	Dr. Eric Punswick
Purpose: (please explain in detail why we need the items or services requested)			
<p>The Standard insurance policies for 2026. Cost is based upon projected participation & employee-paid premium rates for all products. Prior year cost includes short-term and long-term disability, which are reported separately for 2026.</p> <p>Submission of 2026 insurance policies for: Voluntary Group Term Life (GTL) - 2026 Est. Annual \$435,306 (Renewal) Accident Insurance (AI) - 2026 Est. Annual \$66,694 (Renewal) Hospital Insurance (HI) - 2026 Est. Annual \$65,670 (Renewal) Critical Illness Insurance (CI) - 2026 Est. Annual \$50,187 (Renewal) +</p>			
Fund:	Employee paid <input type="checkbox"/>	Account Number:	
Funding Year:	2025/2026 <input type="checkbox"/>	Location(s) items or services are for:	District Wide Benefit
Does this use Bond Funds? (if yes, see below)		No <input type="checkbox"/>	
<input type="checkbox"/> This request includes extended warranty, service or maintenance. Please complete the <u>Bond Warranty Agreement Form on page 2</u>		<input type="checkbox"/> This request includes training or consultation. Please complete <u>Bond Consultant Services Form on Page 3</u>	

Check all that apply to this Purchase:

- | | |
|--|--|
| <input type="checkbox"/> This is a New Contract | <input type="checkbox"/> This is a New Bid/RFP |
| <input checked="" type="checkbox"/> This is a Renewal Contract | <input type="checkbox"/> This is a Purchase from Bid/RFP # _____ |
| <input type="checkbox"/> This is a Curriculum purchase | <input type="checkbox"/> This Purchase requires BOE Signatures |
| <input type="checkbox"/> This can be purchased off of _____ Contract # _____ | |

Begin Date: 1/1/2026	End Date: 12/31/2026
Company: The Standard Insurance Company	Street Address: 11300 Tomahawk Creek Prkwy-St 350 +
Contact Name: Sherri Borgmeyer	City: Overland Park
Telephone: (913) 266-0219	State: KS
Email: sherri.borgmeyer@standard.com	Zip Code: 66210
Cost: \$ 617,857.00 Estimated	
Prior Year Cost: \$ 1,321,198.00 Estimated	
Terms: (Annual, Multi-Year, One-Time): Annual <input type="checkbox"/>	

Month:(board meeting) October 2025 **Budget Administrator** Dr. Eric Punswick **Date**10/1/2025



PURCHASING UNIVERSAL REQUEST

BLUE VALLEY SCHOOL DISTRICT #229

Department/Bldg.:	Facilities and Operartions	Requested By:	Casey Chambers
Purpose: (please explain in detail why we need the items or services requested)			
This is for Blue River Elementary playground 2" mill and overlay and restriping.			
Fund:	Bond	Account Number:	41103450-0
Funding Year:	2025/2026	Location(s) items or services are for:	Blue River Elementary
Does this use Bond Funds? (if yes, see below)		Yes	
<input type="checkbox"/> This request includes extended warranty, service or maintenance. Please complete the <u>Bond Warranty Agreement Form on page 2</u>		<input type="checkbox"/> This request includes training or consultation. Please complete <u>Bond Consultant Services Form on Page 3</u>	

Check all that apply to this Purchase:

- | | |
|--|--|
| <input type="checkbox"/> This is a New Contract | <input type="checkbox"/> This is a New Bid/RFP |
| <input type="checkbox"/> This is a Renewal Contract | <input type="checkbox"/> This is a Purchase from Bid/RFP # _____ |
| <input type="checkbox"/> This is a Curriculum purchase | <input type="checkbox"/> This Purchase requires BOE Signatures |
| <input checked="" type="checkbox"/> This can be purchased off of TIPS | Contract # 23060201 |

Begin Date: 7/22/2025	End Date: 7/31/2025
Company: McConnell & Associates Corp	Street Address: 1225 Iron
Contact Name: Sam Randall	City: North Kansas City,
Telephone: (816) 842-6066	State: MO
Email: s.randall@mcconnellassociates.org	Zip Code: 64116
Cost: \$ 54,370.00 Estimated	
Prior Year Cost:	
Terms: (Annual, Multi-Year, One-Time): One-Time	

Month:(board meeting) October 2025 **Budget Administrator** Jake Slabodnik **Date** 9/16/2025



PROPOSAL

Bid ID Number:58306

Date:7/2/2025

1225 Iron - North Kansas City, Missouri 64116 - Office (816) 842-6066 - Fax (816) 842-1638

<p>Bid Submitted To: Blue Valley School Dist. #229 15020 Metcalf Avenue P. O. Box 23901 Overland Park, KS 66283</p> <p>PHONE: 913-239-4121 FAX: 913-239-4699</p> <p>CONTACT: Casey Chambers</p>	<p>Job Proposed: BVSD - Blue River Elementary Playground 2025 5101W 163rd Terrace Stilwell, KS 66085</p>
---	--

Description	Net Price
<p><u>2" ASPHALT MILL & OVERLAY: 2,600 SY</u> Mill 2" from the entire surface then resurface the entire area with two (2) inches of commercial surface asphalt and compact. Prior to resurfacing, entire area will be primed with SS1H Emulsion so as to insure bond between existing surface and new asphalt overlay. - 1 working day for asphalt milling - 1 working day for asphalt paving / restripe</p>	<p>Asphalt Total Cost \$49,520.00</p>
<p><u>PAINTING: Restripe as Existing</u> Layout lines as existing prior to asphalt overlay. Paint shall be applied with Graco Line Lazer III airless striping machine. Lines shall be straight and four (4) inches in width. Paint shall meet Federal Specification TTP-1952E.</p>	<p>Restripe Total Cost \$1,800.00</p>
	<p>Base Bid Total Cost \$51,320.00</p>
<p><u>Add Alt #1 - Paint US Map Multi Color (1 Total)</u></p>	<p>Add Alt #1 Total Cost \$3,050.00</p>
	<p>Project Total Cost w/ Add Alt #1 \$54,370.00</p>



PROPOSAL

Bid ID Number:58306

Date:7/2/2025

1225 Iron - North Kansas City, Missouri 64116 - Office (816) 842-6066 - Fax (816) 842-1638

<p>Bid Submitted To:</p> <p>Blue Valley School Dist. #229 15020 Metcalf Avenue P. O. Box 23901 Overland Park, KS 66283</p> <p>PHONE: 913-239-4121 FAX: 913-239-4699</p> <p>CONTACT: Casey Chambers</p>	<p>Job Proposed:</p> <p>BVSD - Blue River Elementary Playground 2025 5101W 163rd Terrace Stilwell, KS 66085</p>
--	--

EXCLUSIONS:

Bonds & Permits, Material Testing, Soil Compaction, Grading, Excavation, Any items not listed above.

Note: The property owner or owners agent is responsible for having vehicles removed from the work area prior to 7:00am and on; notification of trades, tenants, etc.; towing of vehicles is the responsibility of the above mentioned. If the crew must return to the site in order to complete the job, a trip charge will be billed.

MOBILIZATIONS: One (1) Working Day = One (1) Mobilization

Each additional mobilization above what is shown will be billed at \$3,500.00 each. The contractor, property owner or owners agent is responsible for having vehicles removed from the work area prior to 7:00am and on; notification of trades, tenants, etc.; towing of vehicles is the responsibility of the above mentioned. If the crew must return to the site in order to complete the job, a trip charge will be billed.

Based on tax exempt prices.

A Project Exemption Certificate must be furnished before the start of work.

All Pricing Based on TIPS-USA 23060201 Pavement and Other Related Services.

<p style="text-align: center;">NOTICE TO OWNER</p> <p>FAILURE OF THIS CONTRACTOR TO PAY THOSE PERSONS SUPPLYING MATERIAL OR SERVICES TO COMPLETE THIS CONTRACT CAN RESULT IN THE FILING OF A MECHANIC'S LIEN ON THE PROPERTY WHICH IS THE SUBJECT OF THIS CONTRACT PURSUANT TO CHAPTER 429, RSMO. TO AVOID THIS RESULT YOU MAY ASK THIS CONTRACTOR FOR "LIEN WAIVERS" FROM ALL PERSONS SUPPLYING MATERIAL OR SERVICES FOR THE WORK DESCRIBED IN THIS CONTRACT. FAILURE TO SECURE LIEN WAIVERS MAY RESULT IN YOUR PAYING FOR LABOR AND MATERIAL TWICE.</p>	<p style="text-align: center;">PAYMENT AND COLLECTION</p> <p>PAYMENT IS DUE UPON RECEIPT OF COMPANY'S INVOICE. IF COMPANY PROVIDES THIS AGREEMENT/PROPOSAL/BID TO AN ATTORNEY FOR ENFORCEMENT OF ITS TERMS, INCLUDING BUT NOT LIMITED TO COLLECTION OF AMOUNTS DUE, YOU AGREE TO PAY ALL EXPENSES AND COSTS, INCLUDING BUT NOT LIMITED TO ATTORNEY'S FEES, EXPERT FEES, COURT COSTS, SERVICE FEES, AND ANY OTHER EXPENSE ASSOCIATED WITH COLLECTION. IN THE EVENT ALL SUMS ARE NOT PAID WHEN DUE, ALL UNPAID SUMS SHALL BEAR INTEREST AT THE (18%) PER ANNUM UNTIL PAID IN FULL.</p>
<p><i>Sam Randall</i> _____ Sam Randall</p>	<p style="text-align: center;">Acceptance of Proposal</p> <p style="text-align: center;"><i>The above prices, specifications and conditions are satisfactory, and are hereby accepted.</i></p> <p>Signature: _____</p> <p>Name & Title (Please Print): _____</p> <p>Date Accepted: _____</p>

NOTES: THIS PROPOSAL MAY BE WITHDRAWN BY US IF NOT ACCEPTED WITHIN 30 DAYS.

Blue River Elementary Playground Lot

5101 W 163rd Terrace, Stilwell, KS 66085

Legend

 Blue River Elementary School

Red Area: 2" Mill & Overlay / Restripe
Total Area: 2,600 SY



PURCHASING UNIVERSAL REQUEST

BLUE VALLEY SCHOOL DISTRICT #229

Department/Bldg.:	Facilities & Operations	Requested By:	Jake Slobodnik
Purpose: (please explain in detail why we need the items or services requested)			
BVNW-2501 SPED			
Professional design and construction administration services for a summer 2026 renovation project in support of SPED program needs at BVNW High School.			
Fund:	Bond	Account Number:	41160355-0
Funding Year:	2025/2026	Location(s) items or services are for:	BVNW
Does this use Bond Funds? (if yes, see below)		Yes	
<input type="checkbox"/> This request includes extended warranty, service or maintenance. Please complete the <u>Bond Warranty Agreement Form on page 2</u>		<input type="checkbox"/> This request includes training or consultation. Please complete <u>Bond Consultant Services Form on Page 3</u>	

Check all that apply to this Purchase:

- | | |
|--|--|
| <input checked="" type="checkbox"/> This is a New Contract | <input type="checkbox"/> This is a New Bid/RFP |
| <input type="checkbox"/> This is a Renewal Contract | <input type="checkbox"/> This is a Purchase from Bid/RFP # _____ |
| <input type="checkbox"/> This is a Curriculum purchase | <input type="checkbox"/> This Purchase requires BOE Signatures |
| <input type="checkbox"/> This can be purchased off of _____ Contract # _____ | |

Begin Date: 10/6/2025	End Date: 12/31/2026
Company: KC Architects LLC	Street Address: 7840 Conser Street
Contact Name: Greg Hasselwander	City: Overland Park, KS
Telephone: (913) 341-3288	State: KS
Email: ghasselwander@kcarch.com	Zip Code: 66204
Cost: \$ 132,000.00 Estimated	
Prior Year Cost:	
Terms: (Annual, Multi-Year, One-Time): One-Time	

Month:(board meeting) October 2025 **Budget Administrator** Jake Slobodnik **Date** 10/6/2025



KC ARCHITECTS, LLC

3 October 2025

Mr. Dan Drake
Blue Valley School District
Director of Facilities and Operations
14950 Metcalf Avenue
Overland Park, KS 66223

Re: BVSD BVNW SPED Classrooms Remodel

KC Architects LLC is pleased to have the opportunity to provide a proposal for architectural and construction administration services for the above-referenced project. Based on the project scope described during our 25 September 2025 meeting, we understand our services for the project to consist of generally:

Providing Architectural and Construction Administration services for a SPED area remodel within an existing locker/commons area at BV Northwest High School to a construction budget of \$1,300,000.00 for the classroom area and \$200,000.00 for locker relocation with floor grind & polish maximum. The remodel may include construction of new walls creating two Classrooms, two Safety Rooms, one Sensory Room, one single-user restroom, one Storage Room, one conference room for twelve people (if possible), casework for a learning kitchen area in one classroom, classroom casework in the other classroom, and associated MEP, Fire, and Technology requirements and finishes.

FIELD VERIFICATION

- 1) Use documentation of existing conditions with field verification.

DESIGN DEVELOPMENT & PERMIT/CONSTRUCTION DOCUMENTS

- 1) Code Study and Life Safety Plan.
- 2) Floor and ceiling plans documenting the areas of work and elements for removal, salvage, replacement, and/or to remain.
- 3) Improvement elevations (photos and/or drawings) documenting existing and new elements.
- 4) Details required to relay design & construction intent.
- 5) Specification information for materials required to complete project construction.
- 6) Provide completed Construction Documents for BVSD review and comment.

CONSTRUCTION ADMINISTRATION

- 1) Provide Construction Administration services including attending regular OAC project meetings throughout the construction period, site visits for urgent issues as required, product submittal review, initial punch list walk and report, and final punch list walk and report.

BVSD BVNW SPED Classrooms Remodel

Compensation for services provided by KC Architects LLC is defined below and includes estimated expenses. Expanded project scope beyond the limits of the funding budget, additional expenses and/or excluded services may be added as defined in the attached 2025 Billing Rate Schedule:

KC Architects, LLC	Architectural & Interior Design Services	Lump sum: \$ 99,400.00
PKMR Engineers	MEP, Fire & Technology	Lump sum: \$ 16,600.00
Bob D Campbell	Structural Engineers	Lump sum: \$ 11,000.00
Sub Total		Lump sum: \$ 127,000.00
Expenses		Lump sum: \$ 5,000.00
Grand Total		Lump sum: \$ 132,000.00



KC ARCHITECTS, LLC

Defined below are excluded Services, that if required, can be added to the project, as an Additional Service to the project:

- Any design services other than Architectural & Interior Design Services as described above, that may be further required because of existing, unrealized, unforeseen conditions found during the project investigation phase. Other design consultants and engineering services are specifically excluded from this proposal but may be added as an additional design service for the project if that course of action is determined to be needed at a later date and upon the approval of the Blue Valley School District.

Again, we appreciate the opportunity to provide this proposal and look forward to working with you and the Blue Valley School District.

Best Regards,

Gregory J. Hasselwander, Principal
KC Architects, LLC



KC ARCHITECTS, LLC

2025 Services Rate Schedule

Compensation for all services will typically be invoiced monthly; billings, which include a breakdown of charges, are due upon receipt. Invoices, that are undisputed, thirty (30) days past due accrue interest at a rate of 1.5% per month (18% annually).

KC Architects, LLC Hourly rates:

Principal:	\$215.00 per hour
Supervisory/Architect:	\$175.00 per hour
Tech. 1 staff:	\$145.00 per hour
Tech. 2 staff:	\$125.00 per hour
Tech. 3 staff:	\$105.00 per hour
Tech. 4 staff/Clerical:	\$95.00 per hour

Expense rates:

Reimbursable expenses:	cost	1.1 x cost
In-house printing/plotting (large format)	\$0.45/SF	
In-house copies (8-1/2" x 11" black/white)	\$0.25/each	
In-house copies (8-1/2" x 11" color)	\$0.85/each	
Out of house copies	actual cost	
Mileage	per Federal Gov's standard mileage rate	
Postage/deliveries	actual cost	
Travel/meals/lodging	actual cost	
Miscellaneous expenses (parking, tolls, etc.)	actual cost	

Consultant services (when reimbursable expense):

1.1 x cost

Reimbursable expenses are defined as project expenses required for a specific project's delivery, but generally include large and small format printing, plotting and reproduction, cost of providing electronic instruments of the Architects professional services, postage, delivery, auto mileage, out-of-town travel (transportation, room and board) and photo/processing, etc. These expenses have been established by the American Institute of Architects in Owner – Architect Agreements as standard reimbursable expenses.

Consultant services, when included in the Services Agreement, are provided by professionals through agreement with KC Architects LLC for specific services which may include Civil, Structural, Mechanical (HVAC, plumbing, fire protection), Electrical, Acoustical, Lighting, Landscape, etc., consulting services. The above Consultant services may also be provided as an additional service when not included in the Services Agreement.

KC Architects LLC shall be entitled to rely upon the accuracy, completeness, and timeliness of all information and/or Consulting services provided by the Client or to the Client, at their direct expense.



PURCHASING UNIVERSAL REQUEST

BLUE VALLEY SCHOOL DISTRICT #229

Department/Bldg.:	Custodial Dept	Requested By:	Matt Brooks
Purpose: (please explain in detail why we need the items or services requested)			
This is for architectural fee for helping us set up the full building painting project in summer of 26. The project number is MLT 2602.			
Fund:	Capital Outlay	Account Number:	31422
Funding Year:	2025/2026	Location(s) items or services are for:	BVNW. BVM, IVE,OHE
Does this use Bond Funds? (if yes, see below)		No	
<input type="checkbox"/> This request includes extended warranty, service or maintenance. Please complete the <u>Bond Warranty Agreement Form on page 2</u>		<input type="checkbox"/> This request includes training or consultation. Please complete <u>Bond Consultant Services Form on Page 3</u>	

Check all that apply to this Purchase:

- This is a New Contract
- This is a Renewal Contract
- This is a Curriculum purchase
- This can be purchased off of _____ Contract # _____
- This is a New Bid/RFP
- This is a Purchase from Bid/RFP # _____
- This Purchase requires BOE Signatures

Begin Date: 10/1/2025	End Date: 8/7/2026
Company: Hollis & Miller Architects Inc	Street Address: 1828 Walnut St Suite 922
Contact Name: Megan Barnes	City: Kansas City
Telephone: (816) 442-7700	State: MO
Email: mbarnes@hollisandmiller.com	Zip Code: 64108
Cost:	\$ 67,500.00
Prior Year Cost:	\$ 32,000.00
Terms: (Annual, Multi-Year, One-Time): One-Time	

Month:(board meeting) October 2025 **Budget Administrator** Matt Brooks **Date** 9/29/2025

August 28, 2025

Matthew Brooks / Chad Luikart
15020 Metcalf Avenue, PO Box 23901
Overland Park, KS 66283-0901

RE: FEE PROPOSAL for Summer 2026 Paint Projects (4 Locations)

The Hollis + Miller Team will Provide limited Design Services and Construction Administration for building wise paint selection and placement at the following locations:

1. **Blue Valley Northwest High School** – Scope to include approximately half the building.
2. **Blue Valley Middle School** – Scope to include full building.
3. **Indian Valley Elementary School** – Scope to include full building.
4. **Oak Hill Elementary School** – Scope to include full building.

Project/Construction Budget is unknown currently. Project to be bid through Blue Valley procurement process and awarded to one or more paint contractors. The current assumption is all construction will be completed during Summer 2026 on or before August 1, 2026. Proposed design/documents and bidding schedule attached.

COMPENSATION FOR SERVICES: Lump Sum / Fixed Fee = \$67,500

Basic Services

• Architectural / Interior Services – Hollis + Miller Architects (BVNW)	\$25,000.00
• Architectural / Interior Services – Hollis + Miller Architects (BVMS)	\$17,500.00
• Architectural / Interior Services – Hollis + Miller Architects (IVE)	\$12,500.00
• Architectural / Interior Services – Hollis + Miller Architects (OHE)	\$12,500.00

Current proposed Fee assumes the following approach (number of meetings, documentation level, etc.)

- (1) Initial Site Walk w/ Matt Brooks (others) to confirm Scope / Approach at each Location
- (1) initial Principal Meeting to Review Scope and initial Concepts/Paint Schemes
- (2) Follow Up Principal Meetings to Finalize Paint Colors, Concepts, Final Locations, etc.
- Design / Paint Concepts (& Revisions) per Building
- Final Documentation per Building
- On-Site Visits to observe Paint Mockups
- On-Site Visits to review questions / provide answers to awarded contractor
- (1) Initial Punchlist per building – multiple areas as needed
- (1) Back-Punch per building – multiple areas as needed
- Notes / Clarifications:
 - Overall scope to match services provided during Summer 2025 projects.
 - Assumed hours for CA in Summer 2026 not to exceed 200 hours between review of shop drawings, drawdowns, mock-ups, on-site visits, responding to contractor questions and punch list. If exceeded, will request additional services at an hourly rate.

CHANGE OF SCOPE

For any work or revisions to drawings, schedules, specifications or other documents, as a result of changes made by the Owner, as defined under the terms of this Agreement, the Architect shall be compensated as may be mutually agreed to by the Owner and Architect.

COMPENSATION FOR ADDITIONAL SERVICES

For requested services not stated or described above. Fee for requested additional services and responsibilities is billed at hourly employees' rates. Hourly rates will be updated on an annual basis.

ARCHITECT

Hollis + Miller Architects
1828 Walnut Street, Suite 922
City, MO 64108

By: 

Megan Barnes, AIA
Senior Associate I Client Leader

Date: 08/28/2025

OWNER

Blue Valley Schools
15020 Metcalf Avenue Kansas
Overland Park, KS

By: _____
Chad Luikart
Assistant Director of Facilities

Date: _____

Exhibit A – PROPOSED DESIGN/DOCUMENTS & BIDDING SCHEDULE

This proposal is based upon the assumed schedule below.

- Sept/Oct 2025 – Hollis & Miller contract approved by Board of Education
- January 30, 2026 – Hollis & Miller deliverables (drawings & scope) due to Matt & Purchasing team
- January 30 – February 10, 2026 -Purchasing works on bid document.
- February 9 or 11, 2026 – Bid Released
- February 13 or 16th – Preproposal Meeting (in-person) & Site Walks
 - No School Days
- March 2, 2026 – Questions due from vendors
- March 5, 2026 – BV sends out final addendum to questions received
- March 11, 2026 – Bids are due from vendors
- March 12 – March 26, 2026 – Blue Valley reviews all bids received
- April 3, 2026 – Finance Committee reviews
- April 7, 2026 – Board of Education approval



PURCHASING UNIVERSAL REQUEST

BLUE VALLEY SCHOOL DISTRICT #229

Department/Bldg.:	Facilities & Operations	Requested By:	Chad Luikart
Purpose: (please explain in detail why we need the items or services requested)			
<p>Provide Basic Services to include Architecture, Structural, and MEP Services for Stilwell Elementary Envelope and Site Improvements. Provide Supplemental Services to include Civil/Landscape, Survey and Estimating Services.</p> <p>The project number is STL 2501.</p>			
Fund:	Bond	Account Number:	41106342-0
Funding Year:	2025/2026	Location(s) items or services are for:	Stilwell Elementary
Does this use Bond Funds? (if yes, see below)		Yes	
<input type="checkbox"/> This request includes extended warranty, service or maintenance. Please complete the <u>Bond Warranty Agreement Form on page 2</u>		<input type="checkbox"/> This request includes training or consultation. Please complete <u>Bond Consultant Services Form on Page 3</u>	

Check all that apply to this Purchase:

- | | |
|--|--|
| <input checked="" type="checkbox"/> This is a New Contract | <input type="checkbox"/> This is a New Bid/RFP |
| <input type="checkbox"/> This is a Renewal Contract | <input type="checkbox"/> This is a Purchase from Bid/RFP # _____ |
| <input type="checkbox"/> This is a Curriculum purchase | <input type="checkbox"/> This Purchase requires BOE Signatures |
| <input type="checkbox"/> This can be purchased off of _____ Contract # _____ | |

Begin Date: 10/1/2025	End Date: 10/7/2026
Company: Hollis and Miller Architects	Street Address: 1828 Walnut St Suite 922
Contact Name: Megan Barnes	City: Kansas City
Telephone: (816) 442-7700	State: MO
Email: mbarnes@hollisandmiller.com	Zip Code: 64108
Cost: \$ 471,000.00 Estimated	
Prior Year Cost:	
Terms: (Annual, Multi-Year, One-Time): One-Time	

Month:(board meeting) October 2025 **Budget Administrator** Chad Luikart **Date** 9/30/2025

September 12, 2025

Jake Slobodnik
Executive Director of Facilities & Operations
15020 Metcalf Avenue, PO Box 23901
Overland Park, KS 66283-0901

RE: FEE PROPOSAL for Stilwell ES Envelope & Site Improvement Project

The Hollis + Miller Team will provide full Architectural services for Envelope and Site Improvements at Stilwell Elementary School at 6410 W 199th St, Stilwell, KS 66085 based on the Assessment/Study completed in mid-2025. Design Development and Construction Documents to be completed in Fall 2025, with Bidding occurring in December 2025. Anticipated GC Contract approval to go to Board of Education in January 2026.

Current Hard Costs/Construction Budget anticipated to be approximately \$6,000,000. Assumption is this will be hard bid / GC project and Construction is to be completed during Summer 2026.

Fee includes two rounds of city / county review comments. If further rounds are needed, additional services may be requested.

COMPENSATION FOR SERVICES: Lump Sum / Fixed Fee = \$471,000

Basic Services

• Architectural Services – Hollis + Miller Architects	\$344,700.00
• Structural Services – Bob D Campbell	\$20,000.00
• MEP Services – Henderson Engineers	<u>\$37,300.00</u>
Subtotal	\$402,000.00

Supplemental Service

• Civil / Landscape Services – MKEC Engineering	\$44,000.00
• Survey Services – MKEC Engineering	\$15,000.00
o <i>Includes title report fee & private utility locate allowance of \$3,000.</i>	
• Estimating Services – CMR (if needed)	<u>\$10,000.00</u>
Subtotal	\$69,000.00

Exclusions:

1. Geotechnical Services
2. Plan Review & Building Permit Fees
3. Special / Construction Testing & Inspections
4. Other Specialty Consultants requested by Owner (not included above)
5. Furniture, Fixtures & Equipment Design Services (FF&E)
6. Graphic Design Supplemental Services

BASIC SCOPE OF SERVICES

Basic design services to include (unless otherwise noted/excluded): Architectural, Structural, MEPF & Civil/Landscape as outlined above.

CHANGE OF SCOPE

For any work or revisions to drawings, schedules, specifications or other documents, as a result of changes made by the Owner, as defined under the terms of this Agreement, the Architect shall be compensated as may be mutually agreed to by the Owner and Architect.

COMPENSATION FOR ADDITIONAL SERVICES

For requested services not stated or described above. Fee for requested additional services and responsibilities is billed at hourly employees' rates. Hourly rates will be updated on an annual basis.

ARCHITECT

Hollis + Miller Architects
1828 Walnut Street, Suite 922
Kansas City, MO 64108

By: 
Megan Barnes, Client Leader

Date: 09/12/2025

OWNER

Blue Valley Schools
15020 Metcalf Avenue
Overland Park, KS

By: _____
Melissa Hillman, Board Attorney

Date: _____

By: _____
Gina Knapp, BOE President

Date: _____





PURCHASING UNIVERSAL REQUEST

BLUE VALLEY SCHOOL DISTRICT #229

Department/Bldg.:	ITS	Requested By:	Rod Freund
Purpose: (please explain in detail why we need the items or services requested)			
<p>26-020 69 Hwy & 167th Repairs - Emergency Purchase</p> <p>Purpose: This repair is for the US-69 Express project where the construction contractor damaged the Blue Valley school district's fiber. BVSD will be refunded by US-69 Express Constructors JV for the repair services completed by K&W Underground Inc.</p> <p>Invoice No. 12442 \$16,385.04 Invoice No. 12443 \$13,703.04</p>			
Fund:	Capital Outlay	Account Number:	33904
Funding Year:	2025/2026	Location(s) items or services are for:	District Wide
Does this use Bond Funds? (if yes, see below)		No	
<input type="checkbox"/> This request includes extended warranty, service or maintenance. Please complete the <u>Bond Warranty Agreement Form on page 2</u>		<input type="checkbox"/> This request includes training or consultation. Please complete <u>Bond Consultant Services Form on Page 3</u>	

Check all that apply to this Purchase:

- | | |
|--|--|
| <input checked="" type="checkbox"/> This is a New Contract | <input type="checkbox"/> This is a New Bid/RFP |
| <input type="checkbox"/> This is a Renewal Contract | <input type="checkbox"/> This is a Purchase from Bid/RFP # _____ |
| <input type="checkbox"/> This is a Curriculum purchase | <input type="checkbox"/> This Purchase requires BOE Signatures |
| <input type="checkbox"/> This can be purchased off of _____ Contract # _____ | |

Begin Date: 8/1/2025	End Date: 9/30/2025
Company: K&W Underground, Inc.	Street Address: 15608 S. Keeler Terr.
Contact Name: Todd Gunther	City: Olathe
Telephone: (913) 782-7387	State: KS
Email: tgunther@kwunderground.com>	Zip Code: 66062
Cost:	\$ 30,088.08
Prior Year Cost:	
Terms: (Annual, Multi-Year, One-Time): One-Time	

Month:(board meeting) October 2025 **Budget Administrator** Brian Daley **Date** 9/8/2025



K&W Underground, Inc.
 15608 S. Keeler Terr.
 Olathe, KS 66062
 Phone: (913) 782-7387
 Fax: (913) 782-1907

Invoice No. 12443

SOLD TO BLUE VALLEY SCHOOL
 15020 METCALF AVE
 OVERLAND PARK, KS 66223

SHIP TO 167th St & 69hwy repairs
 167th St & 69hwy
 Overland Park, KS 66085

ACCOUNT NO	PO NUMBER	SHIP VIA	DATE SHIPPED	TERMS	INVOICE DATE	PAGE
BVSD		Rodney Freund		Net 60	8/27/2025	1

K&W Job # S259029

South repair

ITEM NO	QUANTITY	DESCRIPTION	UNIT PRICE	EXTENDED
	60	Laborer	53.39	3,203.40
	30	Supervisor/ foreman	76.86	2,305.80
	15	Backhoe	78.00	1,170.00
	60	pickup truck	33.60	2,016.00
	15	flatbed truck	45.60	684.00
	3,500	48ct Armored fiber	0.58	2,030.00*
	1	Non-emergency materials and supplies - 20%	2,293.84	2,293.84*

* means item is non-taxable

TOTAL AMOUNT 13,703.04

*** All State and Local taxes included



K&W Underground, Inc.
 15608 S. Keeler Terr.
 Olathe, KS 66062
 Phone: (913) 782-7387
 Fax: (913) 782-1907

Invoice No. 12442

SOLD TO BLUE VALLEY SCHOOL
 15020 METCALF AVE
 OVERLAND PARK, KS 66223

SHIP TO 167th St & 69hwy repairs
 167th St & 69hwy
 Overland Park, KS 66085

ACCOUNT NO	PO NUMBER	SHIP VIA	DATE SHIPPED	TERMS	INVOICE DATE	PAGE
BVSD		Rodney Freund		Net 60	8/27/2025	1

K&W Job # S259029

East repair

ITEM NO	QUANTITY	DESCRIPTION	UNIT PRICE	EXTENDED
	60	Laborer	53.39	3,203.40
	30	Supervisor/ foreman	76.86	2,305.80
	15	Backhoe	78.00	1,170.00
	60	pickup truck	33.60	2,016.00
	15	flatbed truck	45.60	684.00
	1	96ct Armored fiber 5000' foot reel	4,275.00	4,275.00*
	1	Non-emergency materials and supplies - 20%	2,730.84	2,730.84*

* means item is non-taxable

TOTAL AMOUNT 16,385.04

*** All State and Local taxes included



PURCHASING UNIVERSAL REQUEST

BLUE VALLEY SCHOOL DISTRICT #229

Department/Bldg.:	ITS	Requested By:	John Yates
Purpose: (please explain in detail why we need the items or services requested)			
<p>26-023 WSM School Network Equipment- Erate Purpose; This purchase will support the new Wolf Springs Middle school network data system. This was bid through E-Rate.</p>			
Fund:	Bond	Account Number:	45097734-0
Funding Year:	2025/2026	Location(s) items or services are for:	District Wide
Does this use Bond Funds? (if yes, see below)		Yes	
<input type="checkbox"/> This request includes extended warranty, service or maintenance. Please complete the <u>Bond Warranty Agreement Form on page 2</u>		<input type="checkbox"/> This request includes training or consultation. Please complete <u>Bond Consultant Services Form on Page 3</u>	

Check all that apply to this Purchase:

- | | |
|---|--|
| <input type="checkbox"/> This is a New Contract | <input type="checkbox"/> This is a New Bid/RFP |
| <input type="checkbox"/> This is a Renewal Contract | <input type="checkbox"/> This is a Purchase from Bid/RFP # _____ |
| <input type="checkbox"/> This is a Curriculum purchase | <input type="checkbox"/> This Purchase requires BOE Signatures |
| <input checked="" type="checkbox"/> This can be purchased off of ERATE | Contract # FCC Form 470 Number 250011237 |

Begin Date: 10/16/2025	End Date: 5/15/2026
Company: CDW Government Inc	Street Address: 75 Remittance Drive, Suite 1515
Contact Name: Brendan Devlieger	City: Chicago
Telephone: (866) 684-4536	State: IL
Email: brendev@cdwg.com	Zip Code: 60675-1515
Cost: \$ 50,905.00 Estimated	
Prior Year Cost:	
Terms: (Annual, Multi-Year, One-Time): One-Time	

Month:(board meeting) October 2025 **Budget Administrator** Brian Daley **Date** 9/22/2025



Thank you for choosing CDW. We have received your quote.

QUOTE CONFIRMATION

JOHN YATES,

Thank you for considering CDW•G for your technology needs. The details of your quote are below. **If you are an eProcurement or single sign on customer, please log into your system to access the CDW site.** You can search for your quote to retrieve and transfer back into your system for processing.

For all other customers, click below to convert your quote to an order.

Convert Quote to Order

QUOTE #	QUOTE DATE	QUOTE REFERENCE	CUSTOMER #	GRAND TOTAL
PPTQ882	9/19/2025	ERATE MS11	1685938	\$50,905.00

QUOTE DETAILS

ITEM	QTY	CDW#	UNIT PRICE	EXT. PRICE
Juniper EX2300-C Compact Ethernet Switch Mfg. Part#: EX2300-C-12P UNSPSC: 43222612 Contract: MARKET	3	4174696	\$859.00	\$2,577.00
Juniper EX3400 48 Ports Compact Access Ethernet Switch Mfg. Part#: EX3400-48P UNSPSC: 43222612 Contract: MARKET	15	4111095	\$1,987.00	\$29,805.00
Juniper Switch - 12X10G - 36X2.5G - 2X100G Mfg. Part#: EX4400-48MP Contract: MARKET	3	6875745	\$3,611.00	\$10,833.00
Juniper EX4650 48x25GbE+8x100GbE Ethernet Switch Mfg. Part#: EX4650-48Y-AFO UNSPSC: 43222612 Contract: MARKET	1	5237827	\$7,690.00	\$7,690.00

SUBTOTAL	\$50,905.00
SHIPPING	\$0.00
SALES TAX	\$0.00
GRAND TOTAL	\$50,905.00

PURCHASER BILLING INFO	DELIVER TO
------------------------	------------

Billing Address:

BLUE VALLEY SCHOOL DISTRICT
ACCTS PAYABLE
PO BOX 23901
OVERLAND PARK, KS 66283-0901
Phone: (913) 681-4000

Payment Terms: NET 30 Days-Govt/Ed

Shipping Address:

BLUE VALLEY SCHOOL DISTRICT
JOHN YATES
7490 W 149TH TER
OVERLAND PARK, KS 66223-2240

Shipping Method: DROP SHIP-GROUND

Please remit payments to:

CDW Government
75 Remittance Drive
Suite 1515
Chicago, IL 60675-1515



Sales Contact Info

Brendan Devlieger | (866) 684-4534 | brendev@cdwg.com

Need Help?



My Account



Support



Call 800.800.4239

[About Us](#) | [Privacy Policy](#) | [Terms and Conditions](#)

This order is subject to CDW's Terms and Conditions of Sales and Service Projects at

<http://www.cdwg.com/content/terms-conditions/product-sales.aspx>

For more information, contact a CDW account manager.

© 2025 CDW•G LLC, 200 N. Milwaukee Avenue, Vernon Hills, IL 60061 | 800.808.4239



PURCHASING UNIVERSAL REQUEST

BLUE VALLEY SCHOOL DISTRICT #229

Department/Bldg.:	Facility & Operations	Requested By:	Lawrence Saxton
Purpose: (please explain in detail why we need the items or services requested)			
Purchase of tandem compressors.			
Fund:	Capital Outlay	Account Number:	
Funding Year:	2025/2026	Location(s) items or services are for:	BG
Does this use Bond Funds? (if yes, see below)		No	
<input type="checkbox"/> This request includes extended warranty, service or maintenance. Please complete the <u>Bond Warranty Agreement Form on page 2</u>		<input type="checkbox"/> This request includes training or consultation. Please complete <u>Bond Consultant Services Form on Page 3</u>	

Check all that apply to this Purchase:

- | | |
|--|--|
| <input type="checkbox"/> This is a New Contract | <input checked="" type="checkbox"/> This is a New Bid/RFP |
| <input type="checkbox"/> This is a Renewal Contract | <input checked="" type="checkbox"/> This is a Purchase from Bid/RFP # <u>26015</u> |
| <input type="checkbox"/> This is a Curriculum purchase | <input type="checkbox"/> This Purchase requires BOE Signatures |
| <input type="checkbox"/> This can be purchased off of _____ Contract # _____ | |

Begin Date: 10/1/2025	End Date: 12/31/2025
Company: United Refrigeration Inc.	Street Address: 10618 Lackman Road
Contact Name: John Berberich	City: Lenexa
Telephone: (913) 888-4467	State: KS
Email: branchr3@uri.com	Zip Code: 66219
Cost: \$ 30,568.75	
Prior Year Cost: N/A	
Terms: (Annual, Multi-Year, One-Time): One-Time	

Month:(board meeting) October 2025 **Budget Administrator** Jake Slabodnick **Date** 10/1/2025

26015 - Compressors														
Line Item	Quantity	Model	Description	United Refrigeration Inc.			S2 Distribution Inc, dba PTAC Solutions				GMAK Global Inc.			
				Manufacturer Model No.	Unit Cost	Extended Cost	Manufacturer Model No.	Unit Cost	Extended Cost	Additional Information	Manufacturer Model No.	Unit Cost	Extended Cost	Additional Information
1	1	ZRT600KCETED951	Copeland Tandem Unit R22/404 600K @+45/130 460/3 Includes: two contactors 3P 50AMP 120VAC Coil	ZRT600KCETED951	\$ 24,035.12	\$ 24,035.12	ZR300KCE-TED-965	\$ 23,196.00	\$ 23,196.00	Includes Qty 2 of this is required*2			No Bid	
2	1	WARZRT600KCETED951	Limited Extended Compressor Warranty (5-year period from date of purchase but only after OEM warranty expires).	WARZRT600KCETED951	\$ 6,286.69	\$ 6,286.69	Warranty for each ZR300KCE-TED-965	\$ 7,750.00	\$ 7,750.00	Includes warranty on 2 individual compressors.			No Bid	
Added	2		two contactors 3P 50AMP 120VAC Coil		\$ 123.47	\$ 246.94			\$ 0.00					
3	2	ZR250KCETED965	ALTERNATE to Item 1: Copeland Scroll Compressor R22/407 A/C 250K 460/3 Roto	ZR250KCETED965	\$ 8,761.65	\$ 17,523.30	ZR250KCE-TED-965	\$ 9,877.00	\$ 19,754.00		ZR250KCETED965	12,197.89	24,395.78	
4	2	WARZR250KCETED965	ALTERNATE to Item 2: Limited Extended Compressor Warranty (5-year period from date of purchase but only after OEM warranty expires).	WARZR250KCETED965	\$ 2,305.69	\$ 4,611.38	Warranty for ZR250KCE-TED-965	\$ 3,850.00	\$ 7,700.00		48 month extended warranty	3,269.57	6,539.14	
5	2	DP350120F	ALTERNATE if sold separately: IRP DP Contactor 3P 50AMP 120VAC Coil	DP350120F	\$ 123.47	\$ 246.94			\$ 0.00	No Bid.	DP350120F	147.55	295.1	
				Option 1		\$ 30,568.75	Option 1	\$ 30,946.00			Option 1	No Bid		
				Option 2		\$ 22,381.62	Option 2	\$ 27,454.00			Option 2	\$ 31,230.02		
				United Refrigeration Inc.			S2 Distribution Inc, dba PTAC Solutions				GMAK Global Inc.			
Question 1			Can you meet the specifications? Please explain any exceptions.	Yes, no exceptions.			We can meet the specifications if using the current manufactures replacement.				Yes, all products offered are exact from the specified manufacturer and according to the requested part number. All products and quantities will be supplied exactly as requested.			
Question 2			What are typical lead times from order date to delivery date?	These are in stock as of 9/30/205			These are in stock, can ship same day as an order is placed and payment is made.				10-12 weeks ARO			
Question 3			What is the warranty period? Attach warranty coverage details	Compressor comes with 1 year warranty with extended warranty would equal total of 5 years.			1 year manufacture warranty is included on these compressors. The extended warranty would be years 2-5.				Warranty Period Copeland Scroll Compressor model ZR250KCETED965: Warranty Coverage Details The extended warranty applies after expiration of the OEM warranty. Covers replacement or repair of the compressor unit in case of manufacturing defects or failure under normal use. Standard OEM warranty + optional 48-month extended warranty (total of up to 5 years from purchase date). Excludes damages due to misuse, improper installation, lack of maintenance, or use with non-approved refrigerants			
Question 4			How are warranty issues resolved?	Bring Compressor and is replaced with new one - work with United Refrigeration.			Email us and we will work with the manufacture.				Warranty claims are coordinated through AC Parts Distributors. Customer must provide purchase invoice, model/serial numbers, and fault description. Defective units may be required to be returned for inspection before replacement/credit is issued. Service support and logistics will be handled in accordance with AC Parts' procedures and OEM Copeland warranty policies.			
Question 5			Are there tariff fees? What percentage did you assume in your unit pricing for tariff fees, if any?	N/A			N/A.				Country of Origin: United States of America (USA). Tariff Fees: No additional tariff percentage was applied in the quoted unit price. The prices provided are net, free of tariff assumptions, with free USA shipping included			



PURCHASING UNIVERSAL REQUEST

BLUE VALLEY SCHOOL DISTRICT #229

Department/Bldg.:	ITS	Requested By:	Jason Geabhart
Purpose: (please explain in detail why we need the items or services requested)			
<p>26-028 WSMS AV Equipment</p> <p>The purchase of audio/visual (A/V) equipment will support the new Wolf Spring Middle School. The equipment will be installed in both classrooms and common spaces to enhance instructional delivery, student engagement, and collaborative learning. This procurement was conducted under Bid #26016, and KCAV was selected as the winning vendor following the competitive bid process.</p>			
Fund:	Bond	Account Number:	45004736-0
Funding Year:	2025/2026	Location(s) items or services are for:	ITS
Does this use Bond Funds? (if yes, see below)		Yes	
<input type="checkbox"/> This request includes extended warranty, service or maintenance. Please complete the <u>Bond Warranty Agreement Form on page 2</u>		<input type="checkbox"/> This request includes training or consultation. Please complete <u>Bond Consultant Services Form on Page 3</u>	

Check all that apply to this Purchase:

- | | |
|--|--|
| <input type="checkbox"/> This is a New Contract | <input type="checkbox"/> This is a New Bid/RFP |
| <input type="checkbox"/> This is a Renewal Contract | <input checked="" type="checkbox"/> This is a Purchase from Bid/RFP # <u>26016</u> |
| <input type="checkbox"/> This is a Curriculum purchase | <input type="checkbox"/> This Purchase requires BOE Signatures |
| <input type="checkbox"/> This can be purchased off of _____ Contract # _____ | |

Begin Date: 10/15/2025	End Date: 6/30/2026
Company: Kansas City Audio-Visual, Inc	Street Address: 7535 Troost Ave, PO Box 24570
Contact Name: Bobby Cardwell	City: Kansas City
Telephone: (816) 798-5228	State: MO
Email: bcardwell@kcav.com	Zip Code: 64131
Cost: \$ 304,432.52 Estimated	
Prior Year Cost:	
Terms: (Annual, Multi-Year, One-Time): One-Time	

Month:(board meeting) October 2025 **Budget Administrator** Brian Daley **Date** 1/15/2026

26016 - WSM AV Equipment

Line Item	Description	Quantity	Manufacturer Model No.	Kansas City Audio Visual				CDWG			The Tree House, Inc.			ImageNet Consulting, LLC			Vendor Part No.
				Vendor Part No.	Unit Price	Extended Price	Additional Information	Vendor Part No.	Unit Price	Extended Price	Vendor Part No.	Unit Price	Extended Price	Vendor Part No.	Unit Price	Extended Price	
1	Sony Flat Panel Display 98" 4K HDR	2	FW-98BZ53L	FW-98BZ53L	\$ 7,742.8000	\$15,485.60	Quote 54943		\$ 7,748.0000	\$15,496.00	FW-98BZ53L	\$ 9,930.1000	\$19,860.20	FW-98BZ53L	\$ 9,784.1600	\$19,568.32	FW-98BZ53L
2	Sony Flat Panel Display 85" 4K HDR	55	FW-85BZ40L	FW-85BZ40L	\$ 3,309.2000	\$182,006.00	Quote 54943		\$ 3,295.0000	\$181,225.00	FW-85BZ40L	\$ 4,250.4000	\$233,772.00	FW-85BZ40L	\$ 3,940.5900	\$216,732.45	FW-85BZ40L
3	Sony Flat Panel Display 75" 4K HDR	4	FW-75BZ40L	FW-75BZ40L	\$ 2,057.0000	\$ 8,228.00	Quote 54943		\$ 2,057.0000	\$ 8,228.00	FW-75BZ40L	\$ 2,655.4500	\$10,621.80	FW-75BZ40L	\$ 2,605.9500	\$10,423.80	FW-75BZ40L
4	Sony Flat Panel Display 65" 4K HDR	6	FW-65BZ40L	FW-65BZ40L	\$ 1,284.8000	\$ 7,708.80	Quote 54943		\$ 1,287.0000	\$ 7,722.00	FW-65BZ40L	\$ 1,668.7000	\$10,012.20	FW-65BZ40L	\$ 1,629.9200	\$ 9,779.52	FW-65BZ40L
5	Sony Flat Panel Display 55" 4K HDR	20	FW-55BZ40L	FW-55BZ40L	\$ 896.9000	\$17,938.00	Quote 54943		\$ 893.0000	\$17,860.00	FW-55BZ40L	\$ 1,170.7000	\$23,414.00	FW-55BZ40L	\$ 1,072.1600	\$21,443.20	FW-55BZ40L
6	Chief Tilt Mount Extra Large Mirco Adjustable for 55"-100" displays	67	XTM1U	XTM1U	\$ 281.3200	\$18,848.44	Quote 54943		\$ 290.0000	\$19,430.00	XTM1U	\$ 159.9000	\$10,713.30	XTM1U	\$ 291.4500	\$19,527.15	XTM1U
7	Chief Tilt Mount for 32" to 65" displays	20	MTM1U	MTM1U	\$ 154.9300	\$ 3,098.60	Quote 54943		\$ 156.0000	\$ 3,120.00	MTM1U	\$ 159.9000	\$ 3,198.00	MTM1U	\$ 156.6700	\$ 3,133.40	MTM1U
8	Epson Projector 10000 Lumen WUXGA Laser 3LCD w/ 4K Enhancement (No Lens)	3	EB-PU2010W	EB-PU2010W	\$ 9,686.6000	\$29,059.80	Quote 54943		\$10,238.0000	\$30,714.00				EB-PU2010W	\$ 10,563.1400	\$31,689.42	EB-PU2010w
9	Epson Projector Lens Medium Throw Lens	3	ELPLM10	ELPLM10	\$ 1,349.4800	\$ 4,048.44	Quote 54943		\$ 1,425.0000	\$ 4,275.00				ELPLM10	\$ 1,472.0800	\$ 4,416.24	ELPLM10
10	Chief Projector Mount RPA w/ SLB351 Bracket	3	RPA-351	RPA-351	\$ 175.8500	\$ 527.55	Quote 54943		\$ 164.0000	\$ 492.00	RPA-351	\$ 180.6000	\$ 541.80	RPA-351	\$ 176.8900	\$ 530.67	RPA-351
11	Epson Projector 16000 Lumen XPR UHD 4K Laser 3LCD (No Lens)	1	EB-PU2116W	EB-PU2116W	\$ 15,746.3900	\$15,746.39	Quote 54943		\$ 16,645.0000	\$16,645.00				EB-PU2116W	\$ 17,232.6500	\$17,232.65	EB-PU2116W
12	Epson Projector Lens Middle Throw Zoom Lens	1	ELPLM11	ELPLM11	\$ 1,349.4800	\$ 1,349.48	Quote 54943		\$ 1,425.0000	\$ 1,425.00				ELPLM11	\$ 1,472.0400	\$ 1,472.04	ELPLM11
13	Chief Projector Mount Heavy Duty Custom Ceiling Mount w/ HB106E Interface Bracket	1	VCM106E	VCM106E	\$ 387.4200	\$ 387.42	Quote 54943		\$ 369.0000	\$ 369.00	VCM106E	\$ 388.0500	\$ 388.05	VCM106E	\$ 389.7300	\$ 389.73	VCM106E
BID Totals:						\$304,432.52				\$307,001.00			\$312,521.35			\$356,338.59	

imageQUEST		Great Lakes Multimedia Supply, Inc.			Focus Camera			Raj Somas DBA/ rused solutions			B & H Foto & Electronics Corp.				Aztek computers			GOOGOZ.COM, INC.		
Unit Price	Extended Price	Vendor Part No.	Unit Price	Extended Price	Vendor Part No.	Unit Price	Extended Price	Vendor Part No.	Unit Price	Extended Price	Vendor Part No.	Unit Price	Extended Price	Additional Information	Vendor Part No.	Unit Price	Extended Price	Vendor Part No.	Unit Price	Extended Price
\$ 9,546.9400	\$19,093.88	Discontinued Model	\$ 0.0000	\$0.00	FW98BZ53L	\$ 10,269.0000	\$20,538.00		\$ 9,670.0000	\$19,340.00	SOFW98BZ53L	\$ 9,600.4500	\$19,200.90		FW-98BZ53L	\$ 9,376.0000	\$18,752.00		\$ 9,949.1000	\$19,898.20
\$ 4,079.5900	\$224,377.45	FW85BZ40L	\$ 4,315.0000	\$237,325.00	FW85BZ40L	\$ 3,960.0000	\$217,800.00		\$ 3,890.0000	\$213,950.00	SOFW85BZ40L	\$ 4,102.0100	\$225,610.55		FW-85BZ40L	\$ 3,820.0000	\$210,100.00		\$ 4,009.1900	\$220,505.45
\$ 2,535.7100	\$10,142.84	FW75BZ40L	\$ 2,682.0000	\$10,728.00	FW65BZ40L	\$ 1,710.0000	\$6,840.00		\$ 2,575.0000	\$10,300.00	SOFW75BZ40L	\$ 2,550.0000	\$10,200.00		FW-75BZ40L	\$ 2,520.0000	\$10,080.00		\$ 2,680.0000	\$10,720.00
\$ 1,585.7100	\$9,514.26	FW65BZ40L	\$ 1,676.0000	\$10,056.00	FW75BZ40L	\$ 270.0000	\$1,620.00		\$ 1,600.0000	\$9,600.00	SOFW65BZ40L	\$ 1,593.7500	\$9,562.50		FW-65BZ40L	\$ 1,586.0000	\$9,516.00		\$ 1,699.0100	\$10,194.06
\$ 1,106.1200	\$22,122.40	FW55BZ40L	\$ 1,220.0000	\$24,400.00	FW55BZ40L	\$ 1,206.0000	\$24,120.00		\$ 1,060.0000	\$21,200.00	SOFW55BZ40L	\$ 1,111.8300	\$22,236.60		FW-55BZ40L	\$ 1,066.0000	\$21,320.00		\$ 1,148.1600	\$22,963.20
\$ 279.5900	\$18,732.53	XTM1U	\$ 290.0000	\$19,430.00	XTM1U	\$ 297.0000	\$19,899.00		\$ 290.0000	\$19,430.00	CHXTM1U	\$ 245.0000	\$16,415.00	Chief items are bid as "All-or-None"; price valid only if the full quantity of all Chief items are purchased together at one time.	XTM1U	\$ 306.0000	\$20,502.00		\$ 297.1000	\$19,905.70
\$ 150.2600	\$3,005.20	MTM1U	\$ 159.0000	\$3,180.00	MTM1U	\$ 153.0000	\$3,060.00		\$ 150.0000	\$3,000.00	CHMTM1U	\$ 159.0000	\$3,180.00	Chief items are bid as "All-or-None"; price valid only if the full quantity of all Chief items are purchased together at one time.	MTM1U	\$ 181.0000	\$3,620.00		\$ 160.0000	\$3,200.00
\$ 9,935.7100	\$29,807.13	V114A5292	\$10,161.0000	\$30,483.00	EBPU2010W	\$ 13,050.0000	\$39,150.00		\$ 13,545.0000	\$40,635.00	EPEBPU2010W	\$ 10,868.7100	\$32,606.13		EB-PU2010W	\$ 14,520.0000	\$43,560.00		\$ 13,550.0000	\$40,650.00
\$ 1,384.6900	\$4,154.07	V12H004MOA	\$ 1,658.0000	\$4,974.00	ELPLM10	\$ 1,800.0000	\$5,400.00		\$ 1,570.0000	\$4,710.00	EPEPLM10	\$ 1,637.0000	\$4,911.00		ELPLM10	\$ 2,266.0000	\$6,798.00		\$ 1,557.0000	\$4,671.00
\$ 170.1500	\$510.45	RPA-351	\$ 188.0000	\$564.00	RPA-351	\$ 180.0000	\$540.00		\$ 175.0000	\$525.00	CHRPA351	\$ 179.0000	\$537.00	Chief items are bid as "All-or-None"; price valid only if the full quantity of all Chief items are purchased together at one time.	RPA-351	\$ 220.0000	\$660.00		\$ 180.6000	\$541.80
\$ 16,151.0200	\$16,151.02	V11HA6492	\$ 16,660.0000	\$16,660.00	EB-PU2116W	\$ 21,600.0000	\$21,600.00		\$ 19,000.0000	\$19,000.00	EPEBPU2116W	\$ 17,668.0100	\$17,668.01		EB-PU2116W	\$ 21,050.0000	\$21,050.00		\$ 19,100.0000	\$19,100.00
\$ 1,384.6900	\$1,384.69	V12H004M0B	\$ 1,651.0000	\$1,651.00	ELPLM11	\$ 180.0000	\$180.00		\$ 1,570.0000	\$1,570.00	EPEPLM11	\$ 1,514.1600	\$1,514.16		ELPLM11	\$ 1,770.0000	\$1,770.00		\$ 1,557.0000	\$1,557.00
\$ 374.4900	\$374.49	VCM106E	\$ 398.0000	\$398.00	VCM106E	\$ 396.0000	\$396.00		\$ 390.0000	\$390.00	CHVCM106E	\$ 393.7200	\$393.72	Chief items are bid as "All-or-None"; price valid only if the full quantity of all Chief items are purchased together at one time.	ELPLM11	\$ 480.0000	\$480.00		\$ 395.0000	\$395.00
	\$359,370.41			\$359,849.00		\$361,143.00			\$363,650.00				\$364,035.57			\$368,208.00			\$374,301.41	

	ADVANCED MULTIMEDIA SOLUTIONS			Best Buy Stores, L.P.				Bluum Educational Technology			Levin Professional Services, Inc.			BLM Technologies, Inc. dba Teksetra				
Additional Information	Vendor Part No.	Unit Price	Extended Price	Vendor Part No.	Unit Price	Extended Price	Additional Information	Vendor Part No.	Unit Price	Extended Price	Vendor Part No.	Unit Price	Extended Price	Vendor Part No.	Unit Price	Extended Price	Additional Information	Vendor Part No.
Vendor Ship	FW-98BZ53L	\$ 9,210.3100	\$18,420.62	6605013	\$ 9,934.9600	\$19,869.92		FW-98BZ53L	\$ 9,854.6200	\$19,709.24		\$ 10,053.0400	\$20,106.08	SON-FW98BZ53L	\$ 10,089.0000	\$20,178.00		FW98BZ53L
Vendor Ship	FW-85BZ40L	\$ 3,935.3100	\$216,442.05	6641222	\$ 4,269.2200	\$234,807.10		FW-85BZ40L	\$ 4,266.7300	\$234,670.15		\$ 4,286.6400	\$235,765.20	SON-FW85BZ40L	\$ 4,302.0000	\$236,610.00		FW85BZ40L
Vendor Ship	FW-75BZ40L	\$ 2,446.3700	\$9,785.48	6587537	\$ 2,646.0400	\$10,584.16		FW-75BZ40L	\$ 2,571.4300	\$10,285.72		\$ 2,671.2000	\$10,684.80	SON-FW75BZ40L	\$ 2,681.0000	\$10,724.00		FW75BZ40L
Vendor Ship	FW-65BZ40L	\$ 1,528.9700	\$9,173.82	6580297	\$ 1,654.9800	\$9,929.88		FW-65BZ40L	\$ 1,604.0800	\$9,624.48		\$ 1,666.3200	\$9,997.92	SON-FW65BZ40L	\$ 1,672.0000	\$10,032.00		FW65BZ40L
Vendor Ship	FW-55BZ40L	\$ 1,066.6400	\$21,332.80	6552789	\$ 1,155.3400	\$23,106.80		FW-55BZ40L	\$ 1,163.1000	\$23,262.00		\$ 1,163.8800	\$23,277.60	SON-FW55BZ40L	\$ 1,168.0000	\$23,360.00		FW55BZ40L
Vendor Ship	XTM1U	\$ 318.4700	\$21,337.49	8966007	\$ 216.3900	\$14,498.13		XTM1U	\$ 283.8600	\$19,018.62		\$ 303.3000	\$20,321.10	CHI-XTM1U	\$ 290.0000	\$19,430.00		XTM1U
Vendor Ship	MTM1U	\$ 171.2000	\$3,424.00	8799102	\$ 157.6400	\$3,152.80		MTM1U	\$ 150.3600	\$3,007.20		\$ 163.0500	\$3,261.00	CHI-MTM1U	\$ 156.0000	\$3,120.00		MTM1U
Vendor Ship	EB-PU2010W	\$ 16,255.6800	\$48,767.04	6510133 - MF Part Number V11HA52920	\$ 12,711.2300	\$38,133.69	We're showing a different part number than you had listed.	EB-PU2010W	\$ 12,892.8600	\$38,678.58		\$ 13,687.3800	\$41,062.14	EPS-V11HA52920	\$ 13,977.0000	\$41,931.00		V11HA52920
Vendor Ship	ELPLM10	\$ 1,867.0400	\$5,601.12	5664918 - MF Part Number V12H004M0A	\$ 1,629.8700	\$4,889.61	We're showing a different part number than you had listed.	ELPLM10	\$ 1,476.5300	\$4,429.59		\$ 1,572.3400	\$4,717.02	EPS-V12H004M0B	\$ 1,601.0000	\$4,803.00	EOL included replacement model	V12H004M0A
Vendor Ship	RPA-351	\$ 193.2900	\$579.87	BB20933763	\$ 184.8200	\$554.46		RPA-351	\$ 137.9500	\$413.85		\$ 184.0800	\$552.24	CHI-RPA351	\$ 176.0000	\$528.00		RPA351
Vendor Ship	EB-PU2116W	\$ 23,159.0900	\$23,159.09	6542562 - MF Part number V11HA64920	\$ 20,273.3000	\$20,273.30	We're showing a different part number than you had listed.	EB-PU2116W	\$ 18,166.3300	\$18,166.33		\$ 19,285.8200	\$19,285.82	EPS-V11HA64920	\$ 19,693.0000	\$19,693.00		V11HA64920
Vendor Ship	ELPLM11	\$ 1,867.0400	\$1,867.04	5713750 - MF Part Number V12H004M0B	\$ 1,629.8700	\$1,629.87	We're showing a different part number than you had listed.	ELPLM11	\$ 1,476.5300	\$1,476.53		\$ 1,572.3400	\$1,572.34	EPS-V12H004M0B	\$ 1,601.0000	\$1,601.00		V12H004M0B
Vendor Ship	VCM106E	\$ 425.8600	\$425.86	BB20933811	\$ 429.5000	\$429.50	**THIS IS OUT OF STOCK WITH CHIEF DIRECTLY - MAY NEED TO FIND AN ALTERNATIVE**	VCM106E	\$ 403.6500	\$403.65		\$ 405.5700	\$405.57	CHI-VCM106E	\$ 388.0000	\$388.00		VCM106E
			\$380,316.28			\$381,859.22				\$383,145.94			\$391,008.83			\$392,398.00		

E-LOGIC		vPrime Tech Inc				SIRC			Tech Electronics			JAG TECH ENTERPRISES LLC				Dal Entertainment Inc			CCS P
Unit Price	Extended Price	Vendor Part No.	Unit Price	Extended Price	Additional Information	Vendor Part No.	Unit Price	Extended Price	Vendor Part No.	Unit Price	Extended Price	Vendor Part No.	Unit Price	Extended Price	Additional Information	Vendor Part No.	Unit Price	Extended Price	Vendor Part No.
\$ 10,489.5200	\$20,979.04		\$ 9,927.4200	\$19,854.84	Quote expires 09/30. Please reach out to extend quote.	FW98B253L	\$ 10,493.5000	\$20,987.00	FW98B253L	\$ 11,510.0000	\$23,020.00	JTE-FW-98B253L	\$ 11,549.9900	\$23,099.98	Manufacturer's warranty. Delivery within 15 days.		\$ 15,145.0000	\$30,290.00	
\$ 4,424.5900	\$243,352.45		\$ 4,006.6300	\$220,364.65	Quote expires 09/30. Please reach out to extend quote.	FW85B240L	\$ 4,486.1900	\$246,740.45	FW85B240L	\$ 4,918.0000	\$270,490.00	JTE-FW-85B240L	\$ 5,351.5000	\$294,332.50	Manufacturer's warranty. Delivery within 15 days.		\$ 6,485.0000	\$356,675.00	
\$ 2,744.7000	\$10,978.80		\$ 2,644.1000	\$10,576.40	Quote expires 09/30. Please reach out to extend quote.	FW75B240L	\$ 2,794.8100	\$11,179.24	FW75B240L	\$ 3,057.0000	\$12,228.00	JTE-FW-75B240L	\$ 3,316.5000	\$13,266.00	Manufacturer's warranty. Delivery within 15 days.		\$ 4,032.0000	\$16,128.00	
\$ 1,724.5700	\$10,347.42		\$ 1,653.7800	\$9,922.68	Quote expires 09/30. Please reach out to extend quote.	FW65B240L	\$ 1,748.0200	\$10,488.12	FW65B240L	\$ 1,911.0000	\$11,466.00	JTE-FW-65B240L	\$ 2,079.0000	\$12,474.00	Manufacturer's warranty. Delivery within 15 days.		\$ 2,519.0000	\$15,114.00	
\$ 1,220.8100	\$24,416.20		\$ 1,090.1200	\$21,802.40	Quote expires 09/30. Please reach out to extend quote.	FW55B240L	\$ 1,220.3000	\$24,406.00	FW55B240L	\$ 1,383.0000	\$27,660.00	JTE-FW-55B240L	\$ 1,452.0000	\$29,040.00	Manufacturer's warranty. Delivery within 15 days.		\$ 1,760.0000	\$35,200.00	
\$ 322.5300	\$21,609.51		\$ 300.5500	\$20,136.85	Quote expires 09/30. Please reach out to extend quote.	XTM1U	\$ 321.1900	\$21,519.73	XTM1U	\$ 336.0000	\$22,512.00	JTE-XTM1U	\$ 400.4000	\$26,826.80	Manufacturer's warranty. Delivery within 15 days.		\$ 452.0000	\$30,284.00	XTM1U
\$ 180.6800	\$3,613.60		\$ 161.5600	\$3,231.20	Quote expires 09/30. Please reach out to extend quote.	MTM1U	\$ 167.2600	\$3,345.20	MTM1U	\$ 328.0000	\$6,560.00	JTE-MTM1U	\$ 205.3200	\$4,106.40	Manufacturer's warranty. Delivery within 15 days.		\$ 261.0000	\$5,220.00	MTM1U
\$ 14,268.1500	\$42,804.45		\$ 19,870.8500	\$59,612.55	Quote expires 09/30. Please reach out to extend quote.	V11HA52920	\$ 14,761.9900	\$44,285.97	V11HA52920	\$ 14,233.0000	\$42,699.00	JTE-EB-PU2010W	\$ 21,184.9000	\$63,554.70	Manufacturer's warranty. Delivery within 15 days.		\$ 25,672.0000	\$77,016.00	
\$ 1,635.4800	\$4,906.44		\$ 2,512.3600	\$7,537.08	Quote expires 09/30. Please reach out to extend quote.	V12H004M0A	\$ 1,689.0200	\$5,067.06	V12H004M0A	\$ 1,703.0000	\$5,109.00	JTE-ELPLM10	\$ 2,233.4100	\$6,700.23	Manufacturer's warranty. Delivery within 15 days.		\$ 3,246.0000	\$9,738.00	
\$ 196.7000	\$590.10		\$ 182.4200	\$547.26	Quote expires 09/30. Please reach out to extend quote.	RPA351	\$ 194.9400	\$584.82	RPA351	\$ 208.0000	\$624.00	JTE-RPA-351	\$ 236.7200	\$710.16	Manufacturer's warranty. Delivery within 15 days.		\$ 548.0000	\$1,644.00	RPA-351
\$ 19,996.4700	\$19,996.47		\$ 30,922.1300	\$30,922.13	Quote expires 09/30. Please reach out to extend quote.	V11HA64920	\$ 20,799.7700	\$20,799.77	V11HA64920	\$ 20,057.0000	\$20,057.00	JTE-EB-PU2116W	\$ 32,967.0000	\$32,967.00	Manufacturer's warranty. Delivery within 15 days.		\$ 39,950.0000	\$39,950.00	
\$ 1,635.4800	\$1,635.48		\$ 2,512.3600	\$2,512.36	Quote expires 09/30. Please reach out to extend quote.	V12H004M0B	\$ 1,688.9800	\$1,688.98	V12H004M0B_	\$ 1,676.0000	\$1,676.00	JTE-ELPLM11	\$ 2,412.3000	\$2,412.30	Manufacturer's warranty. Delivery within 15 days.		\$ 3,246.0000	\$3,246.00	
\$ 410.1600	\$410.16		\$ 401.8900	\$401.89	Quote expires 09/30. Please reach out to extend quote.	VCM106E	\$ 429.4800	\$429.48	VCM106E	\$ 458.0000	\$458.00	JTE-VCM106E	\$ 520.9600	\$520.96	Manufacturer's warranty. Delivery within 15 days.		\$ 631.0000	\$631.00	VCM106E
	\$405,640.12			\$407,422.29				\$411,521.82			\$444,559.00			\$510,011.03				\$621,136.00	

resentation Systems		School Specialty, Inc.				monoprice			
Unit Price	Extended Price	Vendor Part No.	Unit Price	Extended Price	Additional Information	Vendor Part No.	Unit Price	Extended Price	Additional Information
		NO BID			NO BID	NONE	\$ 0.0000	\$0.00	N/A
		NO BID			NO BID	MP 46411	\$ 1,717.9900	\$94,489.45	LG 86IN LCD TV 3840X2160 UHD NON-WIFI 3YR WARR TV HDMI SPKR
		NO BID			NO BID	MP 47944	\$ 1,213.9900	\$4,855.96	LG 75UR340C9UD 75" LED-LCD TV - 4K UHD TV - LED Backlight - 3840 x 2160 Resolution
		NO BID			NO BID	MP 46414	\$ 916.9900	\$5,501.94	LG 65IN LCD TV 3840X2160 UHD SIMPLE EDITOR WIFI 120HZ HDMI 3YR
		NO BID			NO BID	MP 46410	\$ 733.9900	\$14,679.80	LG 55IN LCD TV 3840X2160 UHD SIMPLE EDITOR WIFI 120HZ HDMI 3YR
\$ 300.0000	\$20,100.00	SSL Item #2153132 MODEL #XTM1U	\$ 407.9900	\$27,335.33	AS SPECIFIED	MP 12994	\$ 59.5000	\$3,986.50	Monoprice Heavy-Duty Tilt TV Wall Mount Extra Wide For 60" To 120" TVs up to 264lbs Max VESA 900x600 Works with Concrete Brick and Wooden Studs
\$ 165.0000	\$3,300.00	SSL Item #2153130 MODEL #MTM1U	\$ 219.3300	\$4,386.60	AS SPECIFIED	MP 43205	\$ 24.1600	\$483.20	Monoprice Essential Tilt TV Wall Mount Bracket For 37" To 80" TVs up to 154lbs Max VESA 600x400 Fits Curved Screens
		MODEL #9AK256	\$ 16,165.3100	\$48,495.93	AS SPECIFIED	NONE	\$ 0.0000	\$0.00	N/A
		MODEL #3H0635	\$ 1,860.3300	\$5,580.99	AS SPECIFIED	MP 47325	\$ 1,353.9900	\$4,061.97	Epson PowerLite L210SW Short Throw 3LCD Projector - 16:10 - Front - 20000 Hour Normal Mode
\$ 187.0000	\$561.00	MODEL #RPA-351	\$ 247.6200	\$742.86	AS SPECIFIED	NONE	\$ 0.0000	\$0.00	N/A
		MODEL #04YY75	\$ 22,777.2800	\$22,777.28	AS SPECIFIED	MP 47346	\$ 527.9900	\$527.99	ViewSonic P5502X 4000 Lumens XGA HDMI Short Throw Projector for Education and Office
		MODEL #3H0636	\$ 1,860.3300	\$1,860.33	AS SPECIFIED	MP 47938	\$ 1,077.9900	\$1,077.99	InFocus LightPro IN0061SL 3D Standard Throw DLP Projector - 16:9 - High Dynamic Range (HDR) - 3840 x 2160 - Front - 2160p
\$ 413.0000	\$413.00	MODEL #VCM106E	\$ 545.5600	\$545.56	AS SPECIFIED	MP 6529	\$ 48.0000	\$48.00	Monoprice Commercial Series Extendable Pole Ceiling Mount Bracket for Projector (Max 50 lbs.)
Incomplete	\$24,374.00		Incomplete	\$111,724.88		Alternates		\$129,712.80	



PURCHASING UNIVERSAL REQUEST

BLUE VALLEY SCHOOL DISTRICT #229

Department/Bldg.:	Blue Valley High	Requested By:	Kale Mann
Purpose: (please explain in detail why we need the items or services requested)			
Supplies for Forensics class using grant funds.			
Fund:		Account Number: Breakthrough Grant	205000088-7014
Funding Year:	2025/2026	Location(s) items or services are for:	BVH
Does this use Bond Funds? (if yes, see below)		No	
<input type="checkbox"/> This request includes extended warranty, service or maintenance. Please complete the <u>Bond Warranty Agreement Form on page 2</u>		<input type="checkbox"/> This request includes training or consultation. Please complete <u>Bond Consultant Services Form on Page 3</u>	

Check all that apply to this Purchase:

- | | |
|--|--|
| <input type="checkbox"/> This is a New Contract | <input checked="" type="checkbox"/> This is a New Bid/RFP |
| <input type="checkbox"/> This is a Renewal Contract | <input checked="" type="checkbox"/> This is a Purchase from Bid/RFP # <u>26017</u> |
| <input type="checkbox"/> This is a Curriculum purchase | <input type="checkbox"/> This Purchase requires BOE Signatures |
| <input type="checkbox"/> This can be purchased off of _____ Contract # _____ | |

Begin Date: 10/1/2025	End Date: 12/31/2025
Company: Amplyus LLC d/b/a MiniPCRBio	Street Address: 1770 Massachusetts Avenue ste. 167
Contact Name: Emmett McCleary	City: Cambridge
Telephone: (781) 990-8727	State: MA
Email: orders@minipcr.com	Zip Code: 02140
Cost: \$ 38,301.00 Estimated	
Prior Year Cost: N/A	
Terms: (Annual, Multi-Year, One-Time): One-Time	

Month:(board meeting) October 2025 **Budget Administrator** Charles Golden **Date** 10/1/2025

26017 - Forensics Supplies															
Line Item	Location	Description	Manufacturer Model No.	SKU #	Quantity	AMPLYUS LLC a/k/a MiniPCR			JAG TECH ENTERPRISES LLC			Additional Information (if needed)	GMAK Global Inc.		
						Vendor Part No.	Unit Price	Extended Price	Vendor Part No.	Unit Price	Extended Price		Vendor Part No.	Unit Price	Extended Price
1	BVH	Mini PCR Premium Pack Includes: (32) MiniPCR mini8 x thermal cycler (32) blueGel Electrophoresis w/ built-in Illuminator-US plug (8) Gyro plus Microcentrifuge variable speed 12k rpm (68) H-Style 2-20 adjustable volume micropipette (4) H-Style .5-10 adjustable volume micropipette (4) H-Style 20-200 adjustable volume micropipette (4) H-Style 100-1000 adjustable volume micropipette (8) H-Style stand for 9 miniPCR micropipettes -classic (16) 200 micropipette tips -2 racks of 96 (4) 10 micropipette tips - 2 racks of 96 (4) 1000 micropipette tips - 2 racks of 100	miniPCR bio	QP-2500-38	3	QP-2500-38	\$ 8,990.00	\$26,970.00	JTE-QP-2500-38	\$ 10,565.6600	\$31,696.98	Manufacturer's warranty. Delivery time 15 days.	QP-2500-38 includes: QP-1000-080 QP-1500-010 QP-1800-020 QP-1001-010 QP-1001-050 QP-1001-030 QP-1001-020 QP-1001-060 CM-1001-010 CM-1001-050 CM-1001-030	\$ 46,347.3400	\$139,042.02
2	BVH	Electrophoresis Forensics Lab: Wrongfully Convicted PCR kit	miniPCR bio	KT-1504-01	14	KT-1504-01	\$ 69.00	\$966.00	JTE-KT-1504-01	\$ 79.4100	\$1,111.74	Manufacturer's warranty. Delivery time 15 days.	KT-1504-01	\$ 86.7700	\$1,214.78
3	BVH	miniPCR Forensics Lab-Analysis of the D1580 VNTR (CL2)	miniPCR bio	KT-1009-01	14	KT-1009-01	\$ 88.00	\$1,232.00	JTE-KT-1009-01	\$ 101.2600	\$1,417.64	Manufacturer's warranty. Delivery time 15 days.	KT-1009-01	\$ 100.6600	\$1,409.24
4	BVH	ZYMO Soil eDNA miniprep kit eDNA Project-Sampling Soil for Antibiotic Resistance (refill kit) (CL2)	miniPCR bio	KT-1012-02	4	KT-1012-02	\$ 137.00	\$548.00	JTE-KT-1012-02	\$ 157.6100	\$630.44	Manufacturer's warranty. Delivery time 15 days.	KT-1012-02 with 2AA13 and KT-1012-01	\$ 172.2800	\$689.12
5	BVH	BlueBox Pro DNA Transilluminator with Fold-a-View imaging hood and US Power supply	miniPCR bio	QP-1700-03-US	6	QP-1700-03-US	\$ 365.00	\$2,190.00	JTE-QP-1700-03-US	\$ 419.8100	\$2,518.86	Manufacturer's warranty. Delivery time 15 days.	QP-1700-03-US	\$ 458.9900	\$2,753.94
6	BVH	SeeGreen All-in-One Agarose Tabs with TBE 20 pcs. (CL3)	miniPCR bio	RG-1500-20	32	RG-1500-20	\$ 42.00	\$1,344.00	JTE-RG-1500-20	\$ 48.3600	\$1,547.52	Manufacturer's warranty. Delivery time 15 days.	RG-1500-20	\$ 52.8200	\$1,690.24
7	BVH	TBE electrophoresis buffer Powder makes 3L (CL3)	miniPCR bio	RG-1502-05	15	RG-1502-05	\$ 16.00	\$240.00	JTE-RG-1502-05	\$ 18.4600	\$276.90	Manufacturer's warranty. Delivery time 15 days.	RG-1502-05	\$ 20.1200	\$301.80
8	BVH	.5 ml microtubes bag of 50 tubes)	miniPCR bio	6AA02	119	6AA02	\$ 3.50	\$416.50	JTE-6AA02	\$ 4.0800	\$485.52	Manufacturer's warranty. Delivery time 15 days.	6AA02	\$ 4.4000	\$523.60
9	BVH	PCR tubes thin-walled 0.2 mL - bag of 1000	miniPCR bio	2AA21	39	2AA21	\$ 79.00	\$3,081.00	JTE-2AA21	\$ 90.9100	\$3,545.49	Manufacturer's warranty. Delivery time 15 days.	2AA21	\$ 99.3400	\$3,874.26
10	BVH	Micropipette Replacement Tips 2-2000 (bag of 100)	miniPCR bio	CM-1001-10	59	CM-1001-10	\$ 4.50	\$265.50	JTE-CM-1001-10	\$ 5.2300	\$308.57	Manufacturer's warranty. Delivery time 15 days.	CM-1001-10	\$ 5.6600	\$333.94
11	BVH	miniRack orange miniRack green miniRack blue miniRack pink (set of 8 rainbow)	miniPCR bio	CM-1003-05	5	CM-1003-05	\$ 72.00	\$360.00	JTE-CM-1003-05	\$ 82.8600	\$414.30	Manufacturer's warranty. Delivery time 15 days.	CM-1003-05 includes: CM-1003-010 CM-1003-020 CM-1003-030 CM-1003-040	\$ 452.7700	\$2,263.85
12	BVH	40-well Microcentrifuge tube rack	miniPCR bio	CM-1003-08	47	CM-1003-08	\$ 5.00	\$235.00	JTE-CM-1003-08	\$ 5.8100	\$273.07	Manufacturer's warranty. Delivery time 15 days.	CM-1003-08	\$ 6.2900	\$295.68
13	BVH	Chopped- Using CRISPR/Cas9 to cut DNA (CL1)	miniPCR bio	KT-1801-01	3	KT-1801-01	\$ 139.00	\$417.00	JTE-KT-1801-01	\$ 159.9100	\$479.73	Manufacturer's warranty. Delivery time 15 days.	KT-1801-01	\$ 174.7900	\$524.37
14	BVH	Learning Lab Companion Kit (CL3)	miniPCRbio	KT-1510-01	1	KT-1510-01	\$ 36.00	\$36.00	JTE-KT-1510-01	\$ 41.4700	\$41.47	Manufacturer's warranty. Delivery time 15 days.	KT-1510-01	\$ 45.2700	\$45.27
Bid Totals:								\$38,301.00			\$44,748.23				\$154,962.06



PURCHASING UNIVERSAL REQUEST

BLUE VALLEY SCHOOL DISTRICT #229

Department/Bldg.:	Blue Valley High	Requested By:	Kale Mann
Purpose: (please explain in detail why we need the items or services requested)			
Purchase of science supplies using grant funds.			
Fund:		Account Number: Breakthrough Grant	205000088-7014
Funding Year:	2025/2026	Location(s) items or services are for:	BVH
Does this use Bond Funds? (if yes, see below)		No	
<input type="checkbox"/> This request includes extended warranty, service or maintenance. Please complete the <u>Bond Warranty Agreement Form on page 2</u>		<input type="checkbox"/> This request includes training or consultation. Please complete <u>Bond Consultant Services Form on Page 3</u>	

Check all that apply to this Purchase:

- | | |
|--|--|
| <input type="checkbox"/> This is a New Contract | <input checked="" type="checkbox"/> This is a New Bid/RFP |
| <input type="checkbox"/> This is a Renewal Contract | <input checked="" type="checkbox"/> This is a Purchase from Bid/RFP # <u>26018</u> |
| <input type="checkbox"/> This is a Curriculum purchase | <input type="checkbox"/> This Purchase requires BOE Signatures |
| <input type="checkbox"/> This can be purchased off of _____ Contract # _____ | |

Begin Date: 10/1/2025	End Date: 12/31/2025
Company: Various	Street Address:
Contact Name:	City:
Telephone:	State:
Email:	Zip Code:
Cost: \$ 34,127.29 Estimated	
Prior Year Cost: N/A	
Terms: (Annual, Multi-Year, One-Time): One-Time	

Month:(board meeting) October 2025 **Budget Administrator** Charles Golden **Date** 10/1/2025

26018 - Science Supplies

26018 - Science Supplies															
Line Item	Description	Manufacturer Model No.	SKU #	Quantity	Finn Scientific, Inc				School Specialty, Inc.				VWR International, LLC		
					Vendor Part No.	Unit Price	Extended Price	Additional Information	Vendor Part No.	Unit Price	Extended Price	Additional Information	Vendor Part No.	Unit Price	Extended Price
1	Sorvall Legend MicrocentrifugeMicro 21 120v Dual	ThermoFisher	75002558	2											
1A	Sorvall Legend MicrocentrifugeMicro 21 120v Dual	ThermoFisher	75002558	2											
2	Hot plate Stirrer top size 10"x10" US plug-115v	Carolina Biological	701040	3					529589	\$ 403.00	\$1,209.00	CORNING #6795-420D; Description STIRRING HOT PLATE 120V/60HZ	76447-024	\$ 592.62	\$1,777.86
3	Digital Incubator 0.7 cu ft US plug-120v	Carolina Biological	701291	2									470230-608	\$ 496.95	\$993.90
4	Magnetic Stirring Bars- 1"x 5/16" pack of 5	Carolina Biological	701091	1	AP5396	\$ 5.53	\$27.65	Sold Each	2138836	\$ 20.28	\$20.28	HEATHROW SCIENTIFIC #120895; Priced as 5pk Sold as 10pk Must order in 10PK; Description MAGNETIC STIR BAR PTFE SMOOTH 25X8MM PK10 WHITE			
5	Magnetic Stirring Bars- 1.5"x 0.31" pack of 5	Carolina Biological	7010912	1	AP5397	\$ 6.58	\$32.90		2138821	\$ 32.46	\$32.46	HEATHROW SCIENTIFIC #120897; Priced as 5pk Sold as 10pk Must order in 10PK; Description MAGNETIC STIR BAR PTFE SMOOTH 35X8MM PK10 WHITE			
6	Denoyer-Geppert Human sexless multi-torso Model	Carolina Biological	566564	1									470004-090	\$ 1,986.85	\$1,986.85
7	Microscope concavity slides- 2 well pack of 12	Carolina Biological	632972	5	ML1379	\$ 20.37	\$101.85						470200-930	\$ 8.22	\$41.10
8	Microscope slide plastic coverslips box of 100	Carolina Biological	632900	5	ML1377	\$ 4.36	\$21.80		030-7471	\$ 8.89	\$44.45	DELTA EDUCATION #030-7471; Description COVER SLIPS PKG/100	470148-658	\$ 2.40	\$12.00
9	Protoslo solution 15mL	Carolina Biological	885141	3											
10	Microscope Slides Storage Box- holds 25 slides	Carolina Biological	634200	5	ML1499	\$ 5.31	\$26.55		2133474	\$ 2.46	\$12.30	UNITED SCIENTIFIC #62211; Description SLIDE STORAGE BOX 25 SLIDES	470151-632	\$ 1.81	\$9.05
11	Somso Human Male Muscular Model 86x49x38 cm	Carolina Biological	56636	1									470015-708 <i>no removeable parts</i>	\$ 2,065.26	\$2,065.26
12	Ampicillin Solution 10 mcg antibiotic magazine	Carolina Biological	806016	2									90002-062	\$ 34.12	\$68.24

26018 - Science Supplies

26018 - Science Supplies															
Line Item	Description	Manufacturer Model No.	SKU #	Quantity	Finn Scientific, Inc				School Specialty, Inc.				VWR International, LLC		
					Vendor Part No.	Unit Price	Extended Price	Additional Information	Vendor Part No.	Unit Price	Extended Price	Additional Information	Vendor Part No.	Unit Price	Extended Price
13	Kanamycin Antibiotic discs	Carolina Biological	806182	2	AB1402 <i>Needs dispenser sold separate</i>	\$ 14.55	\$29.10						470178-414	\$ 21.39	\$42.78
14	Parafilm 4 in W 125-ft Roll	Carolina Biological	215600	2	AP1501	\$ 27.74	\$55.48		592818	\$ 22.00	\$44.00	HEATHROW SCIENTIFIC-PARAFILM #HS234526B; Description PARAFILM M 4INX125FT ROLL			
15	Nutrient AGAR- prepared 500ml plastic bottle	Carolina Biological	776366	5											
16	Nutrient AGAR- dehydrated medium 100g	Carolina Biological	785300	5					1600788	\$ 20.12	\$100.60	ALDON INNOVATING SCIENCE #IS5130; Description NUTRIENT AGAR 100G 23 G/L	470024-748	\$ 27.99	\$139.95
17	Tryptone Yeast Extract powder 500g	Carolina Biological	216746	1											
18	General Purpose Masking Tape (3 rolls per pack)	Carolina Biological	657200	10	AP1734 <i>not 1/2" wide</i>	\$ 3.80	\$114.00	sold by each							
19	Transfer Pipettes plastic microchem (5.0ml pk100)	Carolina Biological	736982	3					1448761 <i>Graduated</i>	\$ 5.71	\$17.13	FREY SCIENTIFIC #1448761; Description PIPETTES GRAD 1 ML CAP 5 ML 160 MM P/100			
20	Nichrome Wire Inoculating Loop 25 gauge	Carolina Biological	703060	30	AP1051	\$ 3.08	\$92.40								
21	Medium Nitrile Gloves 5mil blue (case of 1000)	Carolina Biological	706336a	1	AP7079	\$ 21.00	\$210.00	sold by each in boxes of qty 100	2138895	\$ 55.80	\$55.80	SCHOOL HEALTH #1042372; Priced as Case of 1000; Sold in BX100; Description SCHOOL HEALTH NITRILE GLOVES - MEDIUM - 100/BOX	76518-338	\$ 102.07	\$102.07
22	Large Nitrile Gloves 5mil blue (case of 1000)	Carolina Biological	706337A	1	AP7080	\$ 21.00	\$210.00	sold by each in boxes of qty 100	2140955	\$ 68.20	\$68.20	SCHOOL HEALTH #1042217; Priced as Case of 1000; Sold in BX100; Description SCHOOL HEALTH NITRILE GLOVES - LARGE - 100/BOX	76518-340	\$ 102.07	\$102.07
23	X-Large Nitrile Gloves 5mil blue (case of 1000)	Carolina Biological	706338A	1	AP7081	\$ 21.00	\$210.00	sold by each in boxes of qty 100					76518-342	\$ 104.15	\$104.15
24	PTC Paper Taste Strip packs of 100 each	Fisher	s85287a	6	AP7989	\$ 2.84	\$17.04		160-3645	\$ 2.30	\$13.80	DELTA EDUCATION #160-3645; Description PAPERS PTC TASTE PK/100	470156-310	\$ 1.97	\$11.82

26018 - Science Supplies

26018 - Science Supplies															
Line Item	Description	Manufacturer Model No.	SKU #	Quantity	Flinn Scientific, Inc				School Specialty, Inc.				VWR International, LLC		
					Vendor Part No.	Unit Price	Extended Price	Additional Information	Vendor Part No.	Unit Price	Extended Price	Additional Information	Vendor Part No.	Unit Price	Extended Price
25	1000ml glass narrow-mouth Erlenmeyer flasks (pk6)	Fisher	FB5001000	1	GP9241	\$ 14.10	\$84.60	sold by each	2139730	\$ 35.46	\$35.46	FREY SCIENTIFIC #2139730; Priced as PK6; Sold as Each; Description NM ERLNMEYER FLASK 1000 ML QTY=6	89090-302	\$ 73.29	\$73.29
26	Digital Scale (Ohaus Ranger 3000)	Fisher Scientific	S72709	6					2012760	\$ 355.36	\$2,132.16	OHAUS #30456410; Description BALANCE NAVIGATOR 200G 0.01G	470309-340	\$ 342.42	\$2,054.52
27	Spectrophotometer	Flinn Scientific	AP7026	1	AP7026	\$ 1,232.00	\$1,232.00		1376345	\$ 2,000.00	\$2,000.00	THERMO SCIENTIFIC #840-282500; Description SPECTROPHOTOMETER SPECTRONIC 200 EDUCATOR	470013-168 <i>different specifications</i>	\$ 1,050.34	\$1,050.34
28	Piezoelectric Igniter	Flinn Scientific	AP6286	38	AP6286	\$ 12.72	\$483.36						62866-127	\$ 56.52	\$2,147.76
29	Conductivity Meter uses LED to measure9v battery	Flinn Scientific	AP1493	19	AP1493	\$ 31.71	\$602.49								
30	50ml BURET Flint Glass w/ PTFE stopcock	Flinn Scientific	GP1087	15	GP1087 Flint Glass	\$ 65.94	\$989.10								
31	Test tube Racks (holds 22mm tube size)	Flinn Scientific	AP5376 Wooden	15	AP5376	\$ 13.46	\$201.90		2133475 Plastic	\$ 10.88	\$163.20	UNITED SCIENTIFIC #77804; Description TEST TUBE RACK PC 12 PLACE Alternate item 2011776 EISCO #CH0005C; Description RACK TEST TUBE 12 HOLES 28MM for 16.55	470148-876	\$ 11.50	\$172.50
32	10 mL Volumetric Pyrex Vista Flasks	Flinn Scientific	GP9248	30	GP9248	\$ 23.90	\$717.00								
33	1000 mL Volumetric Borosilicate Glass Flasks	Flinn Scientific	GP4045	2	GP4045	\$ 50.57	\$101.14						470148-798	\$ 27.89	\$55.78
34	Rectangular polypropylene Carboy - 20L	Flinn Scientific	AP7679	2	AP7679 20L	\$ 167.46	\$334.92		2021921 10L	\$ 147.20	\$294.40	EISCO #CH0177A; Priced as 20L Sold in 10L; Description CARBOY POLY W/ STOPCOCK 10 LITER			
35	QWS4 Water Still 120v	Flinn Scientific	AP10170	1	AP10170	\$ 2,570.01	\$2,570.01		2040209	\$ 2,216.12	\$2,216.12	DYNALON #540004-0120; Description QWS4 WATER STILL 120V	470316-884	\$ 2,173.54	\$2,173.54
Subtotal:							\$7,703.35				\$8,459.36				\$15,184.83
Awarded Totals:		\$34,127.29				\$4,451.27				\$180.06					\$1,017.72

26018 - Science Supplies

26018 - Science Supplies																			
Line Item	Description	Manufacturer Model No.	SKU #	Quantity	Fisher Scientific Company LLC				Carolina Biological Supply Company			Utech Products, Inc			Unipak Corp.				
					Vendor Part No.	Unit Price	Extended Price	Additional Information	Vendor Part No.	Unit Price	Extended Price	Vendor Part No.	Unit Price	Extended Price	Vendor Part No.	Unit Price	Extended Price		
1	Sorvall Legend MicrocentrifugeMicro 21 120v Dual	ThermoFisher	75002558	2	7502558	3,227.72	6,455.44	Quoted separately											
1A	Sorvall Legend MicrocentrifugeMicro 21 120v Dual	ThermoFisher	75002558	2	75 002 541 <i>Should have bid a 75 002 558</i>	\$ 2,737.00	\$5,474.00	Thermo Sci Asheville Matched by description. Item # number provided is invalid.				7218423 <i>Should have bid a 1186243</i>	\$ 7,598.06	\$15,196.12					
2	Hot plate Stirrer top size 10"x10" US plug-115v	Carolina Biological	701040	3	FB30786161	\$ 591.51	\$1,774.53	Ohaus - Offer Temperature Ambient +5 to 500 degrees C		\$ 693.00	\$2,079.00	7218424	\$ 773.53	\$2,320.59					
3	Digital Incubator 0.7 cu ft US plug-120v	Carolina Biological	701291	2	S68781A	\$ 735.66	\$1,471.32	Offer Quincy Lab - Aluminum		\$ 629.10	\$1,258.20	7206828	\$ 715.98	\$1,431.96					
4	Magnetic Stirring Bars- 1"x 5/16" pack of 5	Carolina Biological	701091	1	\$68066	\$ 8.54	\$8.54	Bel Art Products - Sold by 10/pk		\$ 10.71	\$10.71	7205091	\$ 18.78	\$18.78					
5	Magnetic Stirring Bars- 1.5"x 0.31" pack of 5	Carolina Biological	7010912	1	\$68067	\$ 11.99	\$11.99	Bel Art Products - Sold by 10/pk. 1.63"		\$ 12.60	\$12.60	7205126	\$ 21.01	\$21.01					
6	Denoyer-Geppert Human sexless multi-torso Model	Carolina Biological	566564	1	S00252	\$ 1,213.40	\$1,213.40	Offer - 3B S00252 24 parts audio cassette not included.		\$ 6,507.72	\$6,507.72	7218425	\$ 7,218.17	\$7,218.17					
7	Microscope concavity slides- 2 well pack of 12	Carolina Biological	632972	5	\$99369	\$ 6.42	\$38.52	Eisco - sold by 10/pk 26x75mm QTY = 6		\$ 20.50	\$102.50	7218426	\$ 29.25	\$146.25					
8	Microscope slide plastic coverslips box of 100	Carolina Biological	632900	5						\$ 4.99	\$24.95	7218427	\$ 11.25	\$56.25					
9	Protoslo solution 15mL	Carolina Biological	885141	3	NC9548699					\$ 8.05	\$24.15	7218428	\$ 14.80	\$44.40					
10	Microscope Slides Storage Box- holds 25 slides	Carolina Biological	634200	5	\$95934B <i>slides above fit box</i>	\$ 3.65	\$18.25	Eisco		\$ 4.05	\$20.25	7218429	\$ 10.15	\$50.75					
11	Somso Human Male Muscular Model 86x49x38 cm	Carolina Biological	56636	1						\$ 8,933.76	\$8,933.76	7218430	\$ 9,907.03	\$9,907.03					
12	Ampicillin Solution 10 mcg antibiotic magazine	Carolina Biological	806016	2						\$ 17.05	\$34.10	7218431	\$ 38.17	\$76.34					

26018 - Science Supplies

Line Item	Description	Manufacturer Model No.	SKU #	Quantity	Fisher Scientific Company LLC				Carolina Biological Supply Company			Utech Products, Inc			Unipak Corp.		
					Vendor Part No.	Unit Price	Extended Price	Additional Information	Vendor Part No.	Unit Price	Extended Price	Vendor Part No.	Unit Price	Extended Price	Vendor Part No.	Unit Price	Extended Price
13	Kanamycin Antibiotic discs	Carolina Biological	806182	2								7218432	\$ 38.17	\$76.34			
14	Parafilm 4 in W 125-ft Roll	Carolina Biological	215600	2	13 374 10	\$ 33.83	\$67.66					7218433	\$ 42.44	\$84.88			
15	Nutrient AGAR- prepared 500ml plastic bottle	Carolina Biological	776366	5	S21808 ND	\$ 29.08	\$145.40	Offer - Carolina Glass bottle				7218434	\$ 36.75	\$183.75			
16	Nutrient AGAR- dehydrated medium 100g	Carolina Biological	785300	5	S71613A	\$ 27.31	\$136.55	Offer - Fischer Technical				7218435	\$ 57.72	\$288.60			
17	Tryptone Yeast Extract powder 500g	Carolina Biological	216746	1								7218436	\$ 160.28	\$160.28			
18	General Purpose Masking Tape (3 rolls per pack)	Carolina Biological	657200	10								7218437	\$ 13.24	\$132.40			
19	Transfer Pipettes plastic microchem (5.0ml pk100)	Carolina Biological	736982	3								7205142	\$ 20.39	\$61.17			
20	Nichrome Wire Inoculating Loop 25 gauge	Carolina Biological	703060	30	NC3760838	\$ 4.13	\$123.90					7218438	\$ 9.81	\$294.30			
21	Medium Nitrile Gloves 5mil blue (case of 1000)	Carolina Biological	706336a	1		\$ 92.87	\$92.87	Offer - High Five Glove Dark Blue Finger thickness 5.5 mil Palm Thickness 4.7 mil				7218439	\$ 247.76	\$247.76			NPF-5M \$ 44.5000 \$44.50
22	Large Nitrile Gloves 5mil blue (case of 1000)	Carolina Biological	706337A	1	19181610	\$ 92.87	\$92.87	Offer - High Five Glove Dark Blue Finger thickness 5.5 mil Palm Thickness 4.7 mil				7218440	\$ 247.76	\$247.76			NPF-5L \$ 44.5000 \$44.50
23	X-Large Nitrile Gloves 5mil blue (case of 1000)	Carolina Biological	706338A	1	19181611	\$ 92.87	\$92.87	Offer - High Five Glove Dark Blue Finger thickness 5.5 mil Palm Thickness 4.7 mil				7218441	\$ 247.76	\$247.76			NPF-5XL \$ 44.5000 \$44.50
24	PTC Paper Taste Strip packs of 100 each	Fisher	s85287a	6	S85287A	\$ 3.21	\$19.26					1330599	\$ 5.72	\$34.32			

26018 - Science Supplies

26018 - Science Supplies																		
Line Item	Description	Manufacturer Model No.	SKU #	Quantity	Fisher Scientific Company LLC				Carolina Biological Supply Company			Utech Products, Inc			Unipak Corp.			
					Vendor Part No.	Unit Price	Extended Price	Additional Information	Vendor Part No.	Unit Price	Extended Price	Vendor Part No.	Unit Price	Extended Price	Vendor Part No.	Unit Price	Extended Price	
25	1000ml glass narrow-mouth Erlenmeyer flasks (pk6)	Fisher	FB5001000	1	FB5001000	\$ 41.83	\$41.83					10170469	\$ 120.23	\$120.23				
26	Digital Scale (Ohaus Ranger 3000)	Fisher Scientific	S72709	6	\$72709	\$ 338.95	\$2,033.70					27144253	\$ 430.45	\$2,582.70				
27	Spectrophotometer	Flinn Scientific	AP7026	1	S06240	\$ 1,739.09	\$1,739.09	Offer - Thermo Sci Spectroscopy. Wavelength Range 340 to 1000				7218442	\$ 1,620.11	\$1,620.11				
28	Piezoelectric Igniter	Flinn Scientific	AP6286	38								7218410	\$ 20.28	\$770.64				
29	Conductivity Meter uses LED to measure 9v battery	Flinn Scientific	AP1493	19								7218411	\$ 45.92	\$872.48				
30	50ml BURET Flint Glass w/ PTFE stopcock	Flinn Scientific	GP1087	15	\$27992	\$ 15.41	\$231.15	Offer - Eisco 3.3 Borosilicate Glass				7218412	\$ 92.12	\$1,381.80				
31	Test tube Racks (holds 22mm tube size)	Flinn Scientific	AP5376 Wooden	15	\$07856 wooden	\$ 11.21	\$168.15					7218413	\$ 21.28	\$319.20				
32	10 mL Volumetric Pyrex Vista Flasks	Flinn Scientific	GP9248	30	\$89392 different type stopper	\$ 5.36	\$160.80	Offer - Eisco White Graduations				7218414	\$ 31.79	\$953.70				
33	1000 mL Volumetric Borosilicate Glass Flasks	Flinn Scientific	GP4045	2	\$89425	\$ 17.09	\$34.18	Offer-Eisco				7218415	\$ 71.38	\$142.76				
34	Rectangular polypropylene Carboy - 20L	Flinn Scientific	AP7679	2	03007648	\$ 190.66	\$381.32	Offer - Thermo Sci Rochester				7218416	\$ 229.18	\$458.36				
35	QWS4 Water Still 120v	Flinn Scientific	AP10170	1	\$81041	\$ 1,900.58	\$1,900.58					7218417	\$ 3,001.46	\$3,001.46				
Subtotal:							\$17,466.31					\$20,444.26		\$50,770.41				\$133.50
Awarded Totals:			\$34,127.29				\$12,443.88					\$15,900.86						\$133.50



PURCHASING UNIVERSAL REQUEST

BLUE VALLEY SCHOOL DISTRICT #229

Department/Bldg.:	Facility & Operations	Requested By:	Caleb Clements
Purpose: (please explain in detail why we need the items or services requested)			
Purchase of shade structure for Blue River Elementary.			
Fund:	Capital Outlay	Account Number:	325049
Funding Year:	2025/2026	Location(s) items or services are for:	BRE
Does this use Bond Funds? (if yes, see below)			
<input type="checkbox"/> This request includes extended warranty, service or maintenance. Please complete the <u>Bond Warranty Agreement Form on page 2</u>		<input type="checkbox"/> This request includes training or consultation. Please complete <u>Bond Consultant Services Form on Page 3</u>	

Check all that apply to this Purchase:

- | | |
|---|--|
| <input type="checkbox"/> This is a New Contract | <input type="checkbox"/> This is a New Bid/RFP |
| <input type="checkbox"/> This is a Renewal Contract | <input type="checkbox"/> This is a Purchase from Bid/RFP # _____ |
| <input type="checkbox"/> This is a Curriculum purchase | <input type="checkbox"/> This Purchase requires BOE Signatures |
| <input checked="" type="checkbox"/> This can be purchased off of Greenbush | Contract # 24.6ESC-PLAYGROUND-REC2024 |
- Contract verified 10/3/25 tlv

Begin Date: 10/1/2025	End Date: 12/31/2025
Company: Athco	Street Address: 13500 W 108th Street
Contact Name: Matt Cline	City: Lenexa
Telephone: (913) 469-5600	State: KS
Email: athco@athcollc.com	Zip Code: 66215
Cost:	\$ 35,305.80
Prior Year Cost:	N/A
Terms: (Annual, Multi-Year, One-Time): One-Time	

Month:(board meeting) October 2025 **Budget Administrator** Jake Slobodnik **Date** 10/1/2025



PURCHASING UNIVERSAL REQUEST

BLUE VALLEY SCHOOL DISTRICT #229

Department/Bldg.:	Custodial	Requested By:	Matt Brooks
Purpose: (please explain in detail why we need the items or services requested)			
Purchasing two robotic scrubbers, one for ABM and one for PRM. These scrubbers will help us clean the extra square footage that the gym additions have added to the nightly building clean.			
Fund:	Capital Outlay	Account Number:	23963
Funding Year:	2025/2026	Location(s) items or services are for:	ABM and PRM
Does this use Bond Funds? (if yes, see below)		No	
<input type="checkbox"/> This request includes extended warranty, service or maintenance. Please complete the <u>Bond Warranty Agreement Form on page 2</u>		<input type="checkbox"/> This request includes training or consultation. Please complete <u>Bond Consultant Services Form on Page 3</u>	

Check all that apply to this Purchase:

- | | |
|--|--|
| <input type="checkbox"/> This is a New Contract | <input type="checkbox"/> This is a New Bid/RFP |
| <input type="checkbox"/> This is a Renewal Contract | <input type="checkbox"/> This is a Purchase from Bid/RFP # _____ |
| <input type="checkbox"/> This is a Curriculum purchase | <input type="checkbox"/> This Purchase requires BOE Signatures |
| <input checked="" type="checkbox"/> This can be purchased off of Omnia Partners | Contract # r211301 |

Begin Date: 9/29/2025	End Date: 10/31/2025
Company: BradyPlus	Street Address: 1200 Erie St
Contact Name: Jill Ward	City: Kansas City
Telephone: (316) 214-3616	State: MO
Email: jill.ward@bradyplus.com	Zip Code: 64116
Cost:	\$ 65,576.00
Prior Year Cost:	N/A - Not Available
Terms: (Annual, Multi-Year, One-Time): One-Time	

Month:(board meeting) October 2025 **Budget Administrator** Matt Brooks **Date** 9/29/2025



(Formerly BradyIFS)

Wichita, KS
 Phone: 316-942-9494
 BradyPLUS.com

QUOTATION

#9794079

9/8/2025

Quote Expires On: 11/07/2025

ORDERED BY: BLUE VALLEY SCHOOL DISTRICT
 P O BOX 23901
 OVERLAND PARK, KS 66283-0901
 USA

SHIP TO: PLEASANT RIDGE MIDDLE SCHOOL
 9000 W 165th St
 Stilwell, KS 66085-9073
 US

Customer ID: 238284	Ship To ID: 241523
Order #: 9794079	Entered By: JILL.WARD
Customer PO #:	

Qty	B/O	Item ID	Description	UoM	Unit Price	Ext Price
<i>Order Note:</i> pricing based off omnia coop contract r211301						
<i>Delivery Instructions:</i> DOCK IS IN THE MIDDLE OF THE MIDDLE + ELEMANTARY SCHOOLS. DOOR TO THE RIGHT WHEN LOOKING AT IT						
1.00	1.00	DELIVERY-MAS SCO	ATTN DRIVERPLEASE SEE BELOW REQUES	EACH	24,000.000	24,000.00
<i>Order Line Notes:</i> 10110-000039 Pudu Intelligent Commercial Cleaning Robot -CC1PRO(Black) 1 \$24,000.00 \$24,000.00						
1.00	1.00	DELIVERY-MAS SCO	ATTN DRIVERPLEASE SEE BELOW REQUES	EACH	2,300.000	2,300.00
2.00	2.00	DELIVERY-MAS SCO	ATTN DRIVERPLEASE SEE BELOW REQUES	EACH	592.000	1,184.00
<i>Order Line Notes:</i> 19888-000019 Scrubbing Consumables Half Year Package X2 2 \$592.00 \$1,184.00						
1.00	1.00	DELIVERY-MAS SCO	ATTN DRIVERPLEASE SEE BELOW REQUES	EACH	204.000	204.00
<i>Order Line Notes:</i> 19999-000650 Carpet Vacuum Assembly 1 \$204.00 \$204.00						
1.00	1.00	DELIVERY-MAS SCO	ATTN DRIVERPLEASE SEE BELOW REQUES	EACH	3,000.000	3,000.00
<i>Order Line Notes:</i> PUDUSERV3YR 3 Year Service Package 1 \$3,000.00 \$3,000.00						
1.00	1.00	DELIVERY-MAS SCO	ATTN DRIVERPLEASE SEE BELOW REQUES	EACH	2,100.000	2,100.00
<i>Order Line Notes:</i> PUDUEXTWARR2 Extended 2 Year Warranty-Total 3 Year 1 \$2,100.00 \$2,100.00						
FUEL :						0.00

SUB-TOTAL:		32,788.00
TAX:		0.00
BALANCE DUE:		32,788.00
<i>Total Lines: 6</i>		



(Formerly BradyIFS)

Wichita, KS
 Phone: 316-942-9494
 BradyPLUS.com

QUOTATION

#9794079

9/8/2025

Quote Expires On: 11/07/2025

ORDERED BY: BLUE VALLEY SCHOOL DISTRICT
 P O BOX 23901
 OVERLAND PARK, KS 66283-0901
 USA

SHIP TO: AUBREY BEND MIDDLE SCHOOL
 12501 W 175th St
 Overland Park, KS 66221-6212
 US

Customer ID: 238284	Ship To ID: 241533
Order #: 9794079	Entered By: JILL.WARD
Customer PO #:	

Qty	B/O	Item ID	Description	UoM	Unit Price	Ext Price
<i>Order Note:</i> pricing based off omnia coop contract r211301						
<i>Delivery Instructions:</i> DELIVER TO BACK BY DUMPSTER						
1.00	1.00	DELIVERY-MAS SCO	ATTN DRIVERPLEASE SEE BELOW REQUES	EACH	24,000.000	24,000.00
<i>Order Line Notes:</i> 10110-000039 Pudu Intelligent Commercial Cleaning Robot -CC1PRO(Black) 1 \$24,000.00 \$24,000.00						
1.00	1.00	DELIVERY-MAS SCO	ATTN DRIVERPLEASE SEE BELOW REQUES	EACH	2,300.000	2,300.00
2.00	2.00	DELIVERY-MAS SCO	ATTN DRIVERPLEASE SEE BELOW REQUES	EACH	592.000	1,184.00
<i>Order Line Notes:</i> 19888-000019 Scrubbing Consumables Half Year Package X2 2 \$592.00 \$1,184.00						
1.00	1.00	DELIVERY-MAS SCO	ATTN DRIVERPLEASE SEE BELOW REQUES	EACH	204.000	204.00
<i>Order Line Notes:</i> 19999-000650 Carpet Vacuum Assembly 1 \$204.00 \$204.00						
1.00	1.00	DELIVERY-MAS SCO	ATTN DRIVERPLEASE SEE BELOW REQUES	EACH	3,000.000	3,000.00
<i>Order Line Notes:</i> PUDUSERV3YR 3 Year Service Package 1 \$3,000.00 \$3,000.00						
1.00	1.00	DELIVERY-MAS SCO	ATTN DRIVERPLEASE SEE BELOW REQUES	EACH	2,100.000	2,100.00
<i>Order Line Notes:</i> PUDUEXTWARR2 Extended 2 Year Warranty-Total 3 Year 1 \$2,100.00 \$2,100.00						
FUEL :						0.00

SUB-TOTAL:		32,788.00
TAX:		0.00
BALANCE DUE:		32,788.00
Total Lines: 6		



PURCHASING UNIVERSAL REQUEST

BLUE VALLEY SCHOOL DISTRICT #229

Department/Bldg.:	ITS	Requested By:	John Yates
Purpose: (please explain in detail why we need the items or services requested)			
26-013 Network Switches Purpose; This purchase of wireless network equipment will support the new Wolf Springs Middle School.			
Fund:	Bond	Account Number:	45097734-0
Funding Year:	2025/2026	Location(s) items or services are for:	District Wide
Does this use Bond Funds? (if yes, see below)		Yes	
<input type="checkbox"/> This request includes extended warranty, service or maintenance. Please complete the <u>Bond Warranty Agreement Form on page 2</u>		<input type="checkbox"/> This request includes training or consultation. Please complete <u>Bond Consultant Services Form on Page 3</u>	

Check all that apply to this Purchase:

- | | |
|---|--|
| <input type="checkbox"/> This is a New Contract | <input type="checkbox"/> This is a New Bid/RFP |
| <input type="checkbox"/> This is a Renewal Contract | <input type="checkbox"/> This is a Purchase from Bid/RFP # _____ |
| <input type="checkbox"/> This is a Curriculum purchase | <input type="checkbox"/> This Purchase requires BOE Signatures |
| <input checked="" type="checkbox"/> This can be purchased off of Greenbush | Contract # 025-F |

Begin Date: 10/16/2025	End Date: 5/15/2026
Company: CDW Government Inc	Street Address: 75 Remittance Drive, Suite 1515
Contact Name: Brendan Devlieger	City: Chicago
Telephone: (866) 684-4536	State: IL
Email: brendev@cdwg.com	Zip Code: 60675-1515
Cost: \$ 166,736.00 Estimated	
Prior Year Cost:	
Terms: (Annual, Multi-Year, One-Time): One-Time	

Month:(board meeting) October 2025 **Budget Administrator** Brian Daley **Date** 9/15/2025



Thank you for choosing CDW. We have received your quote.

QUOTE CONFIRMATION

JOHN YATES,

Thank you for considering CDW•G for your technology needs. The details of your quote are below. **If you are an eProcurement or single sign on customer, please log into your system to access the CDW site.** You can search for your quote to retrieve and transfer back into your system for processing.

For all other customers, click below to convert your quote to an order.

This quote is subject to CDW's Third Party Cloud Services Order Form Terms and Conditions set forth at <https://www.cdwg.com/content/cdwg/en/terms-conditions/third-party-cloud-services-order-form-terms-and-conditions-.html>

Convert Quote to Order

ACCOUNT MANAGER NOTES:

THINGS TO NOTE:

- AIRWAVE IS NOT INCLUDED IN THE BUNDLE AND ARUBA DID NOT QUOTE, PLEASE LET ME KNOW IF YOU NEED THAT ADDED
- VERTIV, I DIDNT HAVE A MODEL #, SO INCLUDED 2 OPTIONS FREQUENTLY PURCHASED, THE 1500VA AND 3000VA OPTION. LET ME KNOW WHICH YOU REQUIRE AND I'LL REMOVE THE OTHER. YOU HAVE PURCHASED A FEW 2000VA'S BUT NOT INCLUDED ON QUOTE CURRENTLY.
- INFORMACAST LICENSES IS CO-TERMED TO YOUR CURRENT LICENSING TERM.

QUOTE #	QUOTE DATE	QUOTE REFERENCE	CUSTOMER #	GRAND TOTAL
PPTR019	9/19/2025	NON ERATE MS11	1685938	\$166,736.00

QUOTE DETAILS				
ITEM	QTY	CDW#	UNIT PRICE	EXT. PRICE
Juniper EX3400 48 Ports Compact Access Ethernet Switch Mfg. Part#: EX3400-48P UNSPSC: 43222612 advertised: 6978.50 greenbush: 6559.79 Contract: Kansas AEPA-025F K-12 Blue Valley School District (025-F)	3	4111095	\$1,987.00	\$5,961.00
Juniper 1600W Power Supply Mfg. Part#: JPSU-1600-C-AC-AFO advertised: 2657.33 greenbush: 2551.03 Contract: Kansas AEPA-025F K-12 Blue Valley School District (025-F)	3	6875749	\$570.00	\$1,710.00
HPE Networking AP-635 (US) - Campus - wireless access point - ZigBee. Blue Mfg. Part#: R7J28A advertised: 856.84 greenbush: 805.42	100	6667331	\$741.00	\$74,100.00

QUOTE DETAILS (CONT.)

Contract: Kansas AEPA-025F K-12 Blue Valley School District (025-F)

<u>HPE Networking - license + 1 Year ArubaCare Support - 1 additional license</u>	100	4361245	\$138.00	\$13,800.00
---	-----	---------	----------	-------------

Mfg. Part#: JW619AAE

UNSPSC: 43233204

advertised: 174.55

greenbush: 169.31

Electronic distribution - NO MEDIA

Contract: Kansas AEPA-025F K-12 Blue Valley School District (025-F)

<u>Cisco 7821 VoIP Phone</u>	70	3179192	\$150.00	\$10,500.00
--	----	---------	----------	-------------

Mfg. Part#: CP-7821-K9=

UNSPSC: 43191511

advertised: 244.38

greenbush: 232.16

Contract: Kansas AEPA-025F K-12 Blue Valley School District (025-F)

<u>Cisco Spare - telephone wall mount kit</u>	70	3179191	\$38.00	\$2,660.00
---	----	---------	---------	------------

Mfg. Part#: CP-7800-WMK=

UNSPSC: 31162313

advertised: 69.82

greenbush: 66.32

Contract: SEKESC Blue Valley School District (022-G)

<u>CISCO VIDEO PHONE 8875 CARBON</u>	70	8325905	\$445.00	\$31,150.00
--	----	---------	----------	-------------

Mfg. Part#: CP-8875-K9=

advertised: 641.38

greenbush: 609.31

Contract: Kansas AEPA-025F K-12 Blue Valley School District (025-F)

<u>Cisco 10 Pack Learning Credit</u>	5	707620	\$0.00	\$0.00
--	---	--------	--------	--------

Mfg. Part#: TRN-CLC-000

UNSPSC: 86101601

Electronic distribution - NO MEDIA

Contract: Kansas AEPA-025F K-12 Blue Valley School District (025-F)

<u>SINGLEWIRE INFORMACAST FUS IPS EP AO</u>	100	6898336	\$16.00	\$1,600.00
---	-----	---------	---------	------------

Mfg. Part#: SSF-%YR-EPA-TIER 3

advertised: 91.76

greenbush: 89.00

Electronic distribution - NO MEDIA

Contract: Kansas AEPA-025F K-12 Blue Valley School District (025-F)

<u>AtlasTED IPX Series IP-CONSOLE-GH - VoIP phone - with Bluetooth interface</u>	4	7323763	\$1,450.00	\$5,800.00
--	---	---------	------------	------------

Mfg. Part#: IP-CONSOLE-GH

advertised: 2377.03

greenbush: 2258.17

Contract: Kansas AEPA-025F K-12 Blue Valley School District (025-F)

<u>Vertiv Liebert IntelliSlot RDU101 -Network Card Remote Monitoring USB Port</u>	3	5606456	\$285.00	\$855.00
---	---	---------	----------	----------

Mfg. Part#: RDU101

UNSPSC: 43201404

advertised: 327.17

greenbush: 317.08

Contract: Kansas AEPA-025F K-12 Blue Valley School District (025-F)

<u>Vertiv Liebert GXT5 Lithium-Ion Online UPS 1500VA 1350W 120V Rack Tower</u>	3	6994432	\$2,250.00	\$6,750.00
--	---	---------	------------	------------

Mfg. Part#: GXT5LI-1500LVRT2UXL

QUOTE DETAILS (CONT.)

advertised: 2491.65
greenbush: 2391.98
Contract: Kansas AEPA-025F K-12 Blue Valley School District (025-F)

[Vertiv Liebert GXT5 Lithium-Ion Online UPS 3000VA 2700W 120V Tower Rack UPS](#) 3 7155549 \$3,950.00 \$11,850.00

Mfg. Part#: GXT5LI-3000LVRT2UXL

advertised: 4379.13
greenbush: 4203.96
Contract: SEKESC Blue Valley School District (022-G)

These services are considered Third Party Services, and this purchase is subject to CDW's [Third Party Cloud Services Terms and Conditions](#), unless you have a written agreement with CDW covering your purchase of products and services, in which case this purchase is subject to such other written agreement.

The third-party Service Provider will provide these services directly to you pursuant to the Service Provider's standard terms and conditions or such other terms as agreed upon directly between you and the Service Provider. The Service Provider, not CDW, will be responsible to you for delivery and performance of these services. Except as otherwise set forth in the Service Provider's agreement, these services are non-cancellable, and all fees are non-refundable.

SUBTOTAL	\$166,736.00
SHIPPING	\$0.00
SALES TAX	\$0.00
GRAND TOTAL	\$166,736.00

PURCHASER BILLING INFO	DELIVER TO
Billing Address: BLUE VALLEY SCHOOL DISTRICT ACCTS PAYABLE PO BOX 23901 OVERLAND PARK, KS 66283-0901 Phone: (913) 681-4000 Payment Terms: NET 30 Days-Govt/Ed	Shipping Address: BLUE VALLEY SCHOOL DISTRICT JOHN YATES 7490 W 149TH TER OVERLAND PARK, KS 66223-2240 Shipping Method: UPS Ground
	Please remit payments to: CDW Government 75 Remittance Drive Suite 1515 Chicago, IL 60675-1515



Sales Contact Info

Brendan Devlieger | (866) 684-4534 | brendev@cdwg.com

Need Help?



My Account



Support



Call 800.800.4239

[About Us](#) | [Privacy Policy](#) | [Terms and Conditions](#)

This order is subject to CDW's Terms and Conditions of Sales and Service Projects at

<http://www.cdw.com/content/terms-conditions/product-sales.aspx>

For more information, contact a CDW account manager.

Cisco

BY PLACING AN ORDER FOR ABOVE CISCO PRODUCTS, Customer acknowledges and agrees: (1) that it is receiving the Cisco Products and Services directly from Cisco Systems Canada Co. ("Cisco") and hereby agrees to the Cisco's terms and conditions ("Cisco Terms"), which can be found at Cisco's Customer Contract Experience site at the following URL:

<https://www.cisco.com/site/us/en/about/legal/contract-experience/index.html>, which includes Cisco's General Terms at the following URL:

https://www.cisco.com/c/dam/en_us/about/doing_business/legal/Cisco_General_Terms.pdf, and the Offer Descriptions at the following URL:

<https://www.cisco.com/c/en/us/about/legal/cloud-and-software/software-terms.html#offer-descriptions-product>, and (2) that Cisco or its affiliates and not Seller will be responsible for the performance of the Cisco Products and Services.

© 2025 CDW•G LLC, 200 N. Milwaukee Avenue, Vernon Hills, IL 60061 | 800.808.4239



PURCHASING UNIVERSAL REQUEST

BLUE VALLEY SCHOOL DISTRICT #229

Department/Bldg.:		ITS		Requested By:		Jason Geabhart	
Purpose: (please explain in detail why we need the items or services requested)							
<p>26-025 Hilltop A/V Refresh Purpose; This purchase will support the A/V projectors refresh project at the Hilltop Learning Center.</p>							
Fund:		Bond		Account Number:		45004736-0	
Funding Year:		2025/2026		Location(s) items or services are for:		District Wide	
Does this use Bond Funds? (if yes, see below)				Yes			
<input type="checkbox"/> This request includes extended warranty, service or maintenance. Please complete the <u>Bond Warranty Agreement Form on page 2</u>				<input type="checkbox"/> This request includes training or consultation. Please complete <u>Bond Consultant Services Form on Page 3</u>			

Check all that apply to this Purchase:

- | | |
|---|--|
| <input type="checkbox"/> This is a New Contract | <input type="checkbox"/> This is a New Bid/RFP |
| <input type="checkbox"/> This is a Renewal Contract | <input type="checkbox"/> This is a Purchase from Bid/RFP # _____ |
| <input type="checkbox"/> This is a Curriculum purchase | <input type="checkbox"/> This Purchase requires BOE Signatures |
| <input checked="" type="checkbox"/> This can be purchased off of <u>Greenbush</u> | Contract # <u>025-F</u> |

Begin Date: 10/16/2025	End Date: 3/15/2026
Company: CDW Government Inc	Street Address: 75 Remittance Drive, Suite 1515
Contact Name: Brendan Devlieger	City: Chicago
Telephone: (866) 684-4536	State: IL
Email: brendev@cdwg.com	Zip Code: 60675-1515
Cost: \$ 266,545.00 Estimated	
Prior Year Cost:	
Terms: (Annual, Multi-Year, One-Time): One-Time	

Month:(board meeting) October 2025 **Budget Administrator** Brian Daley **Date** 9/29/2025



Thank you for choosing CDW. We have received your quote.

Hardware Software Services IT Solutions Brands Research Hub

QUOTE CONFIRMATION

JASON GEABHART,

Thank you for considering CDW•G for your technology needs. The details of your quote are below. **If you are an eProcurement or single sign on customer, please log into your system to access the CDW site.** You can search for your quote to retrieve and transfer back into your system for processing.

For all other customers, click below to convert your quote to an order.

Convert Quote to Order

QUOTE #	QUOTE DATE	QUOTE REFERENCE	CUSTOMER #	GRAND TOTAL
PPXH703	9/24/2025	HILLTOP AV	1685938	\$266,545.00

QUOTE DETAILS				
ITEM	QTY	CDW#	UNIT PRICE	EXT. PRICE
MID ZOOM LENS 7 ELPLM14 Mfg. Part#: V12H004M0E UNSPSC: 45111615 advertised: 6663.00 greenbush: 6429.79 Contract: Kansas AEPA-025F K-12 Blue Valley School District (025-F)	3	4423001	\$4,815.00	\$14,445.00
Epson ELP LM11 - medium-throw zoom lens - 80.6 mm - 121.1 mm Mfg. Part#: V12H004M0B UNSPSC: 45111615 advertised: 1576.04 greenbush: 1520.87 Contract: Kansas AEPA-025F K-12 Blue Valley School District (025-F)	1	4118412	\$1,476.00	\$1,476.00
Epson Pro L30000UNL WUXGA 3000L 3LCD Laser Projector - Black Mfg. Part#: V11H944820 Contract: Kansas AEPA-025F K-12 Blue Valley School District (025-F)	3	6188869	\$63,756.00	\$191,268.00
Epson EB-PU2010B WUXGA 3LCD Laser Projector with 4K Enhancement - no lens Mfg. Part#: V11HA52820 Contract: Kansas AEPA-025F K-12 Blue Valley School District (025-F)	1	6569232	\$10,606.00	\$10,606.00
Sony Bravia Professional Displays FW-98BZ53L BZ53L Series - 98" Class (97.6 Mfg. Part#: FW98BZ53L Contract: Kansas AEPA-025F K-12 Blue Valley School District (025-F)	6	7971052	\$8,125.00	\$48,750.00

SUBTOTAL	\$266,545.00
SHIPPING	\$0.00
SALES TAX	\$0.00
GRAND TOTAL	\$266,545.00

PURCHASER BILLING INFO	DELIVER TO
Billing Address: BLUE VALLEY SCHOOL DISTRICT ACCTS PAYABLE PO BOX 23901 OVERLAND PARK, KS 66283-0901 Phone: (913) 681-4000 Payment Terms: NET 30 Days-Govt/Ed	Shipping Address: BLUE VALLEY SCHOOL DISTRICT JASON GEABHART 7490 W 149TH TER OVERLAND PARK, KS 66223-2240 Shipping Method: DROP SHIP-COMMON CARRIER
	Please remit payments to: CDW Government 75 Remittance Drive Suite 1515 Chicago, IL 60675-1515



Sales Contact Info

Brendan Devlieger | (866) 684-4534 | brendev@cdwg.com

Need Help?



My Account



Support



Call 800.800.4239

[About Us](#) | [Privacy Policy](#) | [Terms and Conditions](#)

This order is subject to CDW's Terms and Conditions of Sales and Service Projects at <http://www.cdwg.com/content/terms-conditions/product-sales.aspx>

For more information, contact a CDW account manager.

© 2025 CDW•G LLC, 200 N. Milwaukee Avenue, Vernon Hills, IL 60061 | 800.808.4239



PURCHASING UNIVERSAL REQUEST

BLUE VALLEY SCHOOL DISTRICT #229

Department/Bldg.:	Facilities & Operations	Requested By:	Lawrence Saxton
Purpose: (please explain in detail why we need the items or services requested)			
Updating Gen 6 Timing System for swim meets to Gen 7 for all pools in the district			
Fund:	Capital Outlay ▼	Account Number:	016000371-7054
Funding Year:	2025/2026 ▼	Location(s) items or services are for:	District Wide Pools
Does this use Bond Funds? (if yes, see below)		No ▼	
<input type="checkbox"/> This request includes extended warranty, service or maintenance. Please complete the <u>Bond Warranty Agreement Form on page 2</u>		<input type="checkbox"/> This request includes training or consultation. Please complete <u>Bond Consultant Services Form on Page 3</u>	

Check all that apply to this Purchase:

- | | |
|--|--|
| <input type="checkbox"/> This is a New Contract | <input type="checkbox"/> This is a New Bid/RFP |
| <input type="checkbox"/> This is a Renewal Contract | <input type="checkbox"/> This is a Purchase from Bid/RFP # _____ |
| <input type="checkbox"/> This is a Curriculum purchase | <input type="checkbox"/> This Purchase requires BOE Signatures |
| <input checked="" type="checkbox"/> This can be purchased off of TIPS | <input checked="" type="checkbox"/> Contract # 230203 |

Begin Date: 11/1/2024	End Date: 12/31/2025
Company: Commercial Aquatic Services Inc	Street Address: 1542 E Spruce ST
Contact Name: Andrew Bohl	City: Olathe
Telephone: (913) 794-6990	State: KS
Email: andrew@commercialaquatics.com	Zip Code: 66051
Cost: \$ 28,354.22	
Prior Year Cost:	
Terms: (Annual, Multi-Year, One-Time): One-Time ▼	

Month:(board meeting) October 2025 **Budget Administrator** Jake Slobodnik **Date** _____



Quote

Quote ID: 53881
 Customer ID: 42
 Employee ID: Kathy
 Quote Expires: 10/3/2025

Location:
 Blue Valley Maintenance Shop
 Lawrence Saxton
 7480 W. 149th Ter.
 Overland Park, KS 66223-2240

Location:
 Blue Valley Maintenance Shop
 Lawrence Saxton
 7480 W. 149th Ter.
 Overland Park, KS 66223-2240
 Business (913) 239-4693 Rick
 Fax (913) 681-4607

Qty	Item	List Price	Unit Price	Total
1	MISC. PARTS AND EQUIPMENT - Colorado Time Gen 7 System (Legacy) and Accessories	\$28,354.22	\$28,354.22	\$28,354.22

Sub Total	\$28,354.22
Taxes	\$0.00
Total	\$28,354.22

Contract #TIPS230203

GEN7 TIMING SYSTEM
 Qty 1
 Model GEN7-TMR-L
 Description

GEN 7 Sports Timer with legacy connections
 The Gen7 Sports Timer is designed to work exclusively with existing CTS timing components and display boards. Incorporates the latest technology with all of the key features of a Colorado Time Systems Console, including up to 12-lane timing, enhanced split handling, start reaction display, automatic lane arming, interface to 3rd party meet management software, scoreboard cycling and more. The hardware and software combination gives you the flexibility to run your meets your way.
 Features:

Intuitive software interface with modern Windows user interface and is touchscreen friendly. Software to be loaded on owner provided laptop.

Flexible user interface options: Windows laptop or tablet is primary user interface, with Ethernet connectivity to the timer.

Robust safeguards, all data is logged and saved on the Gen7. Any issues with user interface are recoverable. Timer will continue running and will finish race without user interface.

Rich diagnostics, integrated pre-meet diagnostic mode to check system set up and allows proactive equipment maintenance

Integrated 2.4GHz Wireless to Scoreboards

Facility network connectivity
 Note: Includes 3-year limited warranty.

GEN7 LAPTOP
 Qty 1
 Model R-600-302
 Description
 Laptop, GEN7 user interface

TOUCHPADS
 Qty 8
 Model TP-78G
 Description
 Aquagrip gutterhung touchpads (78" x 22") US PATENT 5,702,799
 Note: Includes 3-year limited warranty.

ACCESSORIES
 Qty 9
 Model 4000-0040
 Description

PO Box 113, 1542 E. Spruce St., Olathe, KS 660510113, (913) 764-6990, Fax: (913) 764-1470

Special size Touchpad brackets
Gutter diagram/measurements must be supplied upon order

TOUCHPAD CADDY

Qty 1

Model CAD-TP/P

Description

Touchpad caddy for gutterhung touchpads. Holds up to ten touchpads. Some assembly required

SIX-LANE TOUCHPAD SYSTEM

Qty 1

Model TP-SYS-6

Description

Six-lane touchpad system for the CTS timing system

Includes the primary six-lane cable harness (CH41-6), (7) seven pushbuttons (PB-6), vacuum pump (VP-2), and touchpad meter (TPM-D).

TOUCHPADS NOT INCLUDED

TIMING ACCESSORIES

Qty 8

Model PB-6

Description

Additional push buttons for lane timing

START SYSTEM

Qty 1

Model INF-PRO

Description

Infinity Pro Series Starter with microphone

Features:

High Visibility Adjustable Intensity Strobe

Built-in horn with adjustable volume and alternative tone

Fast charging internal battery and automatic shut-off feature

START SYSTEM ACCESSORIES

Qty 1

Model START-FPM-2

Description

Flagpole mount for the Infinity or Champ series start system

ACCESSORIES

Qty 1

Model R-10DC

Description

Data cable - 10ft

START SYSTEM ACCESSORIES

Qty 1

Model M2-C15

Description

Ergonomically designed microphone for CTS start systems. Features include: two conveniently located start buttons on the top of the microphone for ease of operation for right- and left-handed users, a quiet push-to-talk switch, and a 15ft coiled cable.

Ground Shipping Included

Terms And Conditions

We are pleased to provide you with this quotation for your consideration.

1. This quote is valid for 30 days from the above date, after which the dollar amount may be subject to change.
2. Pricing shown is based on information available at the time of quotation and is subject to review upon order execution.
3. Shipping charges are estimates only and the actual charge may be different at the time of shipment.
4. You may incur restocking fees if you choose to return any items included in this quote. Restocking fees vary per manufacturer.
5. Any changes to this quotation must be made in writing to CAS.

THANK YOU!



PURCHASING UNIVERSAL REQUEST

BLUE VALLEY SCHOOL DISTRICT #229

Department/Bldg.:	Facilities & Operations	Requested By:	Lawrence Saxton
Purpose: (please explain in detail why we need the items or services requested)			
143081-C-L CTS Backstroke Start Device Long Bracket for all pools in the district this device will help with better take off in back stroke position			
Fund:	Capital Outlay ▼	Account Number:	016000371-7054
Funding Year:	2025/2026 ▼	Location(s) items or services are for:	District Wide Pools
Does this use Bond Funds? (if yes, see below)		No ▼	
<input type="checkbox"/> This request includes extended warranty, service or maintenance. Please complete the <u>Bond Warranty Agreement Form on page 2</u>		<input type="checkbox"/> This request includes training or consultation. Please complete <u>Bond Consultant Services Form on Page 3</u>	

Check all that apply to this Purchase:

- | | |
|--|--|
| <input type="checkbox"/> This is a New Contract | <input type="checkbox"/> This is a New Bid/RFP |
| <input type="checkbox"/> This is a Renewal Contract | <input type="checkbox"/> This is a Purchase from Bid/RFP # _____ |
| <input type="checkbox"/> This is a Curriculum purchase | <input type="checkbox"/> This Purchase requires BOE Signatures |
| <input checked="" type="checkbox"/> This can be purchased off of TIPS | <input checked="" type="checkbox"/> Contract # 230203 |

Begin Date: 11/1/2024	End Date: 12/31/2025
Company: Commercial Aquatic Services Inc	Street Address: 1542 E Spruce ST
Contact Name: Andrew Bohl	City: Olathe
Telephone: (913) 794-6990	State: KS
Email: andrew@commercialaquatics.com	Zip Code: 66051
Cost: \$ 38,455.60	
Prior Year Cost:	
Terms: (Annual, Multi-Year, One-Time): One-Time ▼	

Month:(board meeting) October 2025 **Budget Administrator** Jake Slobodnik **Date** _____

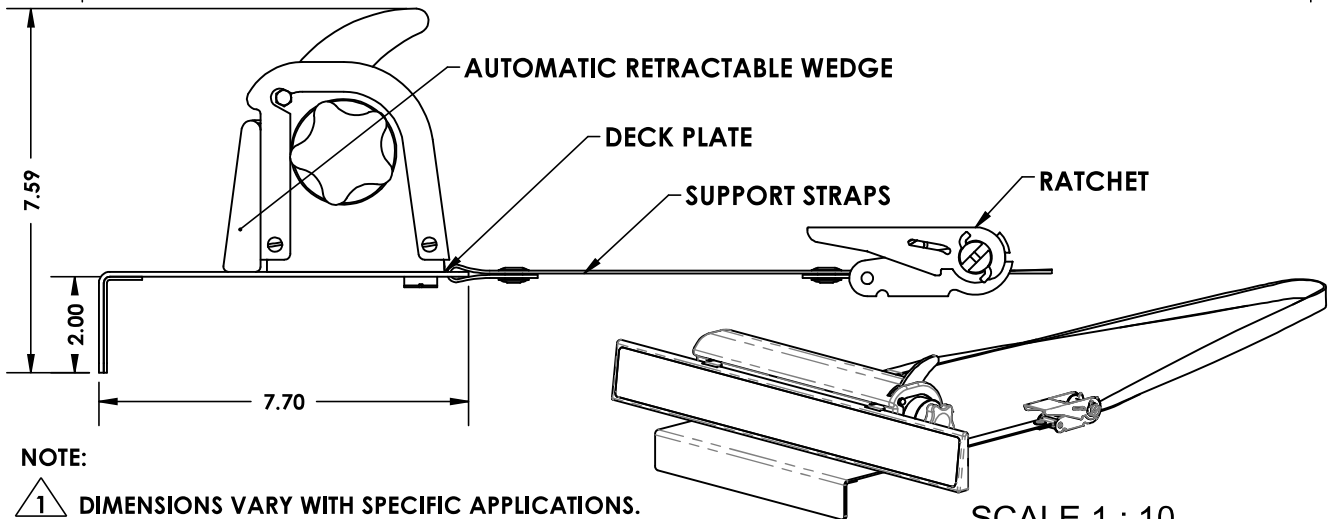
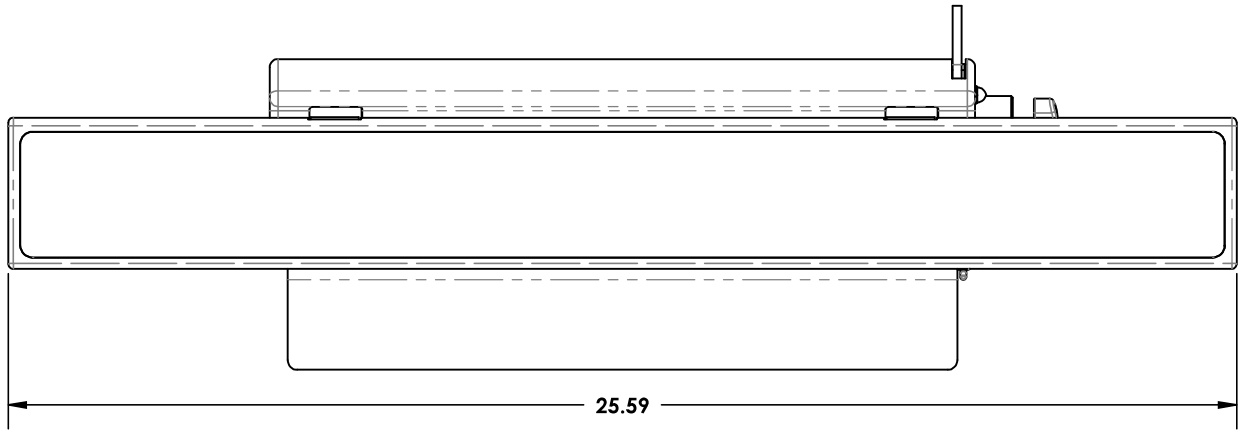
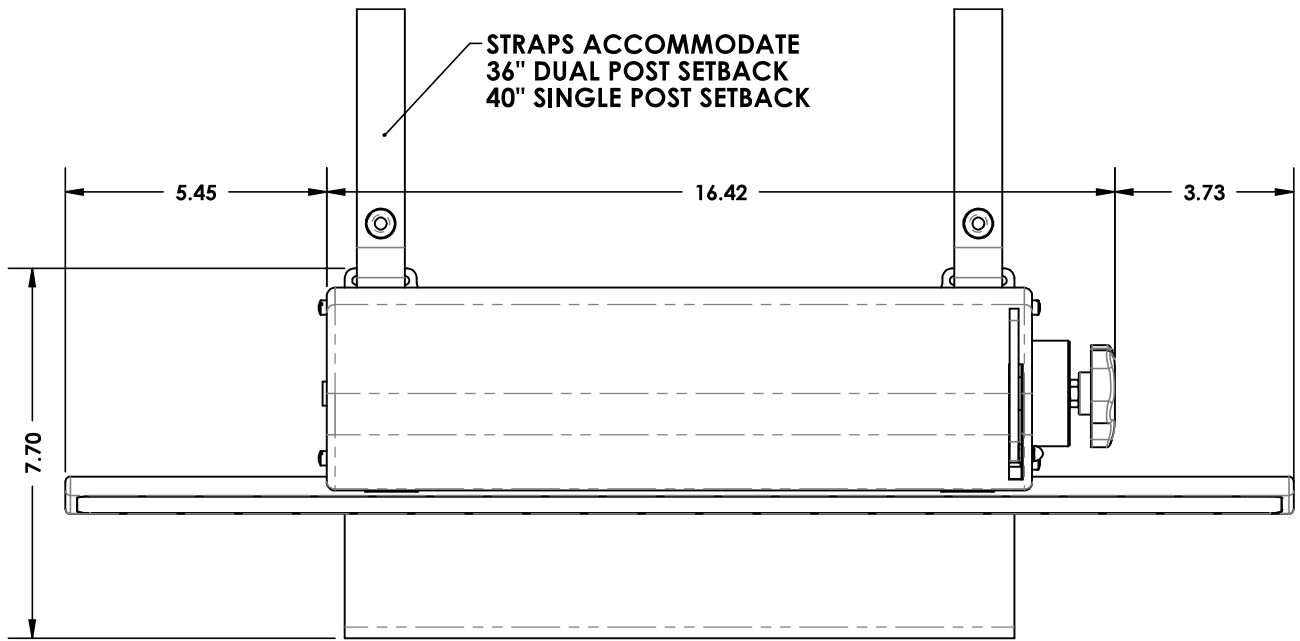

NOTE:

1 DIMENSIONS VARY WITH SPECIFIC APPLICATIONS.
 SPECIFICATIONS ARE NOMINAL AND ARE SUBJECT TO CHANGE.
 PLEASE CONTACT SPECTRUM AQUATICS FOR CUSTOM APPLICATIONS.

SCALE 1 : 10



7100 SPECTRUM LANE
 MISSOULA, MT 59808
 VOICE: 406.542.9781
 FAX: 406.542.1158

ENGINEERING DATA

PRODUCT:	BS ASSIST DEVICE
PRODUCT #:	143081-C-L
REVISION:	B
MATERIAL:	304L STAINLESS STEEL



Quote

Quote ID: 53879
 Customer ID: 42
 Employee ID: Kathy
 Quote Expires: 10/3/2025

Blue Valley Maintenance Shop
 Lawrence Saxton
 7480 W. 149th Ter.
 Overland Park, KS 66223-2240

Location:
 Blue Valley Maintenance Shop
 Lawrence Saxton
 7480 W. 149th Ter.
 Overland Park, KS 66223-2240
 Business (913) 239-4693 Rick
 Fax (913) 681-4607

Qty	Item	List Price	Unit Price	Total
40	143081-C-L - CTS Backstroke Start Device Long Bracket	\$1,005.48	\$941.64	\$37,665.60
1	SHIPPING-KS - Shipping - Kansas	\$790.00	\$790.00	\$790.00

Sub Total	\$38,455.60
Taxes	\$0.00
Total	\$38,455.60

Additional Comments

Contract #TIPS230203

No installation required. The coaches put them in before swim meets and when they need for training.

They are custom based off of each type of gutter system.

Terms And Conditions

We are pleased to provide you with this quotation for your consideration.

1. This quote is valid for 30 days from the above date, after which the dollar amount may be subject to change.
2. Pricing shown is based on information available at the time of quotation and is subject to review upon order execution.
3. Shipping charges are estimates only and the actual charge may be different at the time of shipment.
4. You may incur restocking fees if you choose to return any items included in this quote. Restocking fees vary per manufacturer.
5. Any changes to this quotation must be made in writing to CAS.

THANK YOU!



PURCHASING UNIVERSAL REQUEST

BLUE VALLEY SCHOOL DISTRICT #229

Department/Bldg.:	Facilities and Operations	Requested By:	Andy Spruill
Purpose: (please explain in detail why we need the items or services requested)			
This purchase is for maintenance request, preventative maintenance, and standard dashboard software (Go FMX).			
Fund:	Capital Outlay	Account Number:	016000210-6504
Funding Year:	2025/2026 ▼	Location(s) items or services are for:	All B&G
Does this use Bond Funds? (if yes, see below)		No ▼	
<input type="checkbox"/> This request includes extended warranty, service or maintenance. Please complete the <u>Bond Warranty Agreement Form on page 2</u>		<input type="checkbox"/> This request includes training or consultation. Please complete <u>Bond Consultant Services Form on Page 3</u>	

Check all that apply to this Purchase:

- | | |
|--|--|
| <input type="checkbox"/> This is a New Contract | <input type="checkbox"/> This is a New Bid/RFP |
| <input type="checkbox"/> This is a Renewal Contract | <input type="checkbox"/> This is a Purchase from Bid/RFP # _____ |
| <input type="checkbox"/> This is a Curriculum purchase | <input type="checkbox"/> This Purchase requires BOE Signatures |
| <input checked="" type="checkbox"/> This can be purchased off of TIPS _____ | Contract # _____ |

Begin Date: 11/21/2025	End Date: 11/20/2026
Company: Facilities Management Express LLC	Street Address: 800 Yard St., Suite 115
Contact Name: Logan Fields	City: Columbus
Telephone: (614) 328-9195	State: OH
Email: logan.fields@gofmx.com	Zip Code: 43212
Cost: \$ 29,404.62 Estimated ▼	
Prior Year Cost: \$ 43,562.40	
Terms: (Annual, Multi-Year, One-Time): Annual ▼	

Month:(board meeting) October 2025 **Budget Administrator** Jake Slobodnik **Date**9/23/2025



www.gofmx.com
 1 (844) 664-4400
 800 Yard St., Suite 115
 Columbus, OH 43212

FMX Quote Summary

Address Information

Contact Name Andy Spruill
 Email arspruill@bluevalleyk12.org
 Account Name Blue Valley Unified School District 229
 Billing Address 15020 Metcalf Ave.
 Overland Park, Kansas 66223
 United States
 Phone (913) 239-4000

Quote Information

Quote Number 00012377
 Expiration Date 11/20/2025
 Prepared By Logan Fields
 Email logan.fields@gofmx.com

Product	Line Item Description	Sales Price	Quantity	Total Price
FMX Subscription Fee	FMX Subscription Fee	\$3,150.00	1.00	\$3,150.00
FMX K-12 Basics Bundle	Maintenance Request, Preventive Maintenance, Standard Dashboards	\$16,997.40	1.00	\$16,997.40
Interactive Mapping	Interactive Mapping	\$5,814.90	1.00	\$5,814.90
Feature	Inventory	\$3,354.75	1.00	\$3,354.75
Feature	Commissioned Reports - Capital Forecasting Dashboard	\$2,236.50	1.00	\$2,236.50
Feature	Satisfaction Surveys	\$1,118.25	1.00	\$1,118.25
FMX Recurring Discount	Recurring TIPS Discount	(\$3,267.18)	1.00	(\$3,267.18)

Grand Total: \$29,404.62

Contract Start Date 11/21/2025

Contract End Date 11/20/2026

See below for more detailed information on your Subscription Summary and Implementation Process.

Quote Acceptance Information

Term

The Initial Term for the subscription shall be from the date of execution of this agreement (signature date) for one (1) calendar year, unless otherwise specified in your subscription agreement.

Billing

Prices shown above do not include any state and local taxes that may apply. Any such taxes are the responsibility of the Customer and will appear on the Invoice if necessary. If you are exempt from sales tax, please send the required tax exemption documents to billing@gofmx.com. Invoices for this order will be emailed automatically from billing@gofmx.com.

Renewal

The subscription term will automatically renew for successive periods equal to the initial term unless either party notifies the other in writing at least thirty (30) days prior to expiration of the then current term.

By signing this Sales Order, you are agreeing to the [FMX Terms of Use](#) as incorporated herein.

Signature: _____

Name: _____



www.gofmx.com
1 (844) 664-4400
800 Yard St., Suite 115
Columbus, OH 43212

Title: _____

Date: _____

Subscription Summary

- Data imports from provided templates
- Site customization (custom fields, approval processes, email notifications, etc.)
- Site specific branding (URL and Logo)
- Mobile Access
- Basic reporting
- Full access to asset management and reporting
- Premier support and training
 - Dedicated Customer Success Manager
 - Remote-training
 - Access to online FMX Learning Center
 - Live email and telephone support (Monday – Friday 8:00am-6:00pm EST)

Learn more about our [Post Launch Implementation Requirements](#).



PURCHASING UNIVERSAL REQUEST

BLUE VALLEY SCHOOL DISTRICT #229

Department/Bldg.:	ITS	Requested By:	Kent Corser
Purpose: (please explain in detail why we need the items or services requested)			
<p>26-027 Insight Global Staffing This will provide 2 desktop support personnel for future use if needed for a 180 Day contract. 1040 x 2 = 2080 X \$40.00 per hour for a total of \$83,200.</p>			
Fund:	Capital Outlay	Account Number:	34803
Funding Year:	2025/2026	Location(s) items or services are for:	ITS / SSC
Does this use Bond Funds? (if yes, see below)		No	
<input type="checkbox"/> This request includes extended warranty, service or maintenance. Please complete the <u>Bond Warranty Agreement Form on page 2</u>		<input type="checkbox"/> This request includes training or consultation. Please complete <u>Bond Consultant Services Form on Page 3</u>	

Check all that apply to this Purchase:

- | | |
|--|--|
| <input type="checkbox"/> This is a New Contract | <input type="checkbox"/> This is a New Bid/RFP |
| <input type="checkbox"/> This is a Renewal Contract | <input type="checkbox"/> This is a Purchase from Bid/RFP # _____ |
| <input type="checkbox"/> This is a Curriculum purchase | <input type="checkbox"/> This Purchase requires BOE Signatures |
| <input checked="" type="checkbox"/> This can be purchased off of <u>Omnia Partners</u> | Contract # <u>2021003051</u> |

Begin Date: 10/15/2025	End Date: 6/30/2026
Company: INSIGHT GLOBAL LLC	Street Address: 1100 Walnut Street, Suite 1250
Contact Name: Hannah Kiefer	City: Kansas City
Telephone: (816) 835-2168	State: MO
Email: Hannah.Kiefer@InsightGlobal.com	Zip Code: 64105
Cost: \$ 83,200.00 Estimated	
Prior Year Cost:	
Terms: (Annual, Multi-Year, One-Time): One-Time	

Month:(board meeting) October 2025 **Budget Administrator** Brian Daley **Date** 10/1/2025



PURCHASING UNIVERSAL REQUEST

BLUE VALLEY SCHOOL DISTRICT #229

Department/Bldg.:	Facility & Operations	Requested By:	Jake Slobodnik
Purpose: (please explain in detail why we need the items or services requested)			
Purchase of two station restroom trailers for use at construction projects.			
Fund:	Capital Outlay	Account Number:	016001991-7083
Funding Year:	2025/2026	Location(s) items or services are for:	
Does this use Bond Funds? (if yes, see below)		No	
<input type="checkbox"/> This request includes extended warranty, service or maintenance. Please complete the <u>Bond Warranty Agreement Form on page 2</u>		<input type="checkbox"/> This request includes training or consultation. Please complete <u>Bond Consultant Services Form on Page 3</u>	

Check all that apply to this Purchase:

- | | |
|---|--|
| <input type="checkbox"/> This is a New Contract | <input type="checkbox"/> This is a New Bid/RFP |
| <input type="checkbox"/> This is a Renewal Contract | <input type="checkbox"/> This is a Purchase from Bid/RFP # _____ |
| <input type="checkbox"/> This is a Curriculum purchase | <input type="checkbox"/> This Purchase requires BOE Signatures |
| <input checked="" type="checkbox"/> This can be purchased off of <u>Sourcewell</u> Contract # <u>092922-AGO</u> | |

Contract verified 10/3/2025 tlv

Begin Date: 10/1/2025	End Date: 12/31/2025
Company: Ready2Go Trailer Sales	Street Address: 1525 Park Manor Blvd
Contact Name: Lee Currie	City: Pittsburgh
Telephone:	State: PA
Email: lee@ready2gotrailer.com	Zip Code: 15205
Cost: \$ 136,734.00	
Prior Year Cost: N/A	
Terms: (Annual, Multi-Year, One-Time): One-Time	

Month:(board meeting) October 2025 **Budget Administrator** Jake Slobodnik **Date** 10/1/2025

Products & Services

Item & Description	Quantity	Unit Price	Total	Image
<p>UltraLav - 3 Station 20' ADA+2 Restroom Trailer</p> <p>INTERIOR</p> <ul style="list-style-type: none"> · High Clearance Sink (ADA Compliant) · Auto-Shutoff Sink Faucet · Shatter Proof Mirror · Ceramic Toilet (ADA Compliant) · Toilet Paper Holder · Paper Towel Dispenser · Waste Basket · Smooth, Aluminum Poly-Cor Registered Interior Walls & Ceiling · Non-Skid Rubber Coin Floor · Interior Turning Radius and Exterior Landing Turning Radius (Meets or Exceeds ADA Requirements) · Handrails And Grab Bars Are 1-1/2" Stainless Steel (ADA Compliant) · 12v LED 6" Round Dome Lights (4 per) <p>EXTERIOR</p> <ul style="list-style-type: none"> · ADA Ramp System With 1 1/4" Stainless Steel Railings (ADA Compliant) · 36" W Entry Door (Exceeds ADA Requirements) · 12V LED Porch Light · 3" Quick Connect Waste Tank Access Valve · Waste Tank Level (Sight Glass) · City Water Hook-Up · Scissor Jack <p>MECHANICALS</p> <ul style="list-style-type: none"> · Roof Mounted A/C with Heat Strip · Wall Mounted Thermostat · On-Board Fresh Water System (105 Gallons) 	2	\$63,900.00	\$127,800.00	

Item & Description	Quantity	Unit Price	Total	Image
--------------------	----------	------------	-------	-------

- 6 Gallon Electric Water Heater
- PEX Manifold Water Distribution System
- 120V 30-amp Motor base with Twist Lock
- 120V 30-amp 25' Shoreline
- Polyethylene Waste Tank (3/8" Walls)
- White Vinyl Walls in Mechanical Closet

*Standard Features Subject to Change without notice

HIGHLIGHTS

- No. of stations: ADA-1, Standard-2
- Sinks: 3
- Toilets: 3
- Urinals: 1
- No. of AC Units: 1
- Box Size: 20' x 6'
- Weight: 5,375 lbs. (will vary based on features)
- Freshwater Tank: 105-Gallons
- Waste Tank: 375-Gallons
- Power Requirements: Two dedicated 120 Volt-20-amp circuit (will vary based on features)

ADA+2 UltraLav Restroom Trailer 3-Season Wall Heater in each room, including maintenance room Additional Electrical Service Added	2	\$3,000.00	\$6,000.00
--	---	------------	------------

Giltner Logistics - Freight/ Delivery Charge Transport/ Delivery of Equipment	2	\$1,467.00	\$2,934.00
---	---	------------	------------

One-time subtotal \$136,734.00

Total \$136,734.00

The sale is subject to the following conditions and representations:

Full payment from the Buyer is to take place prior to removal from the Seller's property. The Seller warrants to Buyer that the unit is new and in good condition. Seller reserves the right to display the Buyer's solution in their marketing materials (including but not limited to the Ready2Go website). The Parties hereto specifically consent to the jurisdiction of the courts of the state of Pennsylvania in connection with any formal litigation or other claims brought by either Party hereto arising under this Agreement. The manufacturer's Statement of Origin (MSO) will be provided by mail (2-6 weeks from delivery, after final payment has been received unless otherwise agreed), and used to register the unit with the appropriate local jurisdiction for title and plate issuance. The Buyer is responsible for all state and local taxes, registration fees, and any other charges that may apply to the transaction. Please verify that the Federal Tax ID and the Buyer and/or Company name provided herein are both correct. By signing below, both parties acknowledge and agree to the conditions and representations outlined in this Bill of Sale.

Net 30

Signature

Signature

Date

Printed name

Questions? Contact me



Lee Currie
Government Sales
lee@ready2gotrailers.com

Ready2Go Trailer Sales LLC
1525 Park Manor Blvd
#300
Pittsburgh, PA 15205
United States



1503 McNaughton Ave.
Elkhart, IN 46514
Phone: (574) 264-9661

Date: 4/27/2023

To: Sourcewell Member

Subject: Authorized Approved Dealers for Sourcewell Contract

To whom it may concern,

American Cargo Group was awarded a contract for Sourcewell Solicitation Number: RFP #092922 (Trailers with Related Equipment, Accessories, and Services)

American Cargo Group's Sourcewell contract number is: 092922-AGO

As stated in our RFP response, American Cargo Group does not sell direct but rather through a select group of Authorized Dealers. Any Authorized Dealer selected to process a Sourcewell trailer order/purchase through this contact has met stringent requirements, is a dealer in good standing, and has agreed to all the terms and conditions outlined in the Sourcewell Contract.

This letter confirms that the dealer listed below is an official authorized dealer for American Cargo Group.

Ready2Go Restroom Trailers Sales LLC
1525 Park Manor Blvd #300
Pittsburgh, PA 15205
Primary Contact: Mark Rosen
Phone: 412-498-2632
Email: mark@ready2gorestroomtrailers.com
Website: ready2gorestroomtrailers.com

Should you have any questions or require further assistance, please do not hesitate to contact our dedicated Fleet Sales Manager, Valerie Burleigh. Her contact information can be found below. We are here to help ensure that your trailer purchase through American Cargo Group is professional, timely, and accurate.

Sincerely,

Mike Nichols
Vice President Sales
American Cargo Group

Valerie Burleigh
Phone: 254-386-6702
Email: valerie.burleigh@americancargogroup.com





PURCHASING UNIVERSAL REQUEST

BLUE VALLEY SCHOOL DISTRICT #229

Department/Bldg.:	Business Office	Requested By:	Nicole Hogan
Purpose: (please explain in detail why we need the items or services requested)			
Purchase of 20 sewing machine tables for Wolf Springs Middle			
Fund:	Bond	Account Number:	40011730-0
Funding Year:	2025/2026	Location(s) items or services are for:	WSM
Does this use Bond Funds? (if yes, see below)		Yes	
<input type="checkbox"/> This request includes extended warranty, service or maintenance. Please complete the <u>Bond Warranty Agreement Form on page 2</u>		<input type="checkbox"/> This request includes training or consultation. Please complete <u>Bond Consultant Services Form on Page 3</u>	

Check all that apply to this Purchase:

- | | |
|--|--|
| <input type="checkbox"/> This is a New Contract | <input type="checkbox"/> This is a New Bid/RFP |
| <input type="checkbox"/> This is a Renewal Contract | <input type="checkbox"/> This is a Purchase from Bid/RFP # _____ |
| <input type="checkbox"/> This is a Curriculum purchase | <input type="checkbox"/> This Purchase requires BOE Signatures |
| <input checked="" type="checkbox"/> This can be purchased off of Omnia Partners | Contract # R-TC-18004 |

Begin Date: 10/7/2025	End Date: 7/30/2026
Company: Virco Inc	Street Address: 2027 Harpers Way
Contact Name: Roman Totta	City: Torrance
Telephone: (913) 327-9975	State: CA
Email: romantotta@virco.com	Zip Code: 90501
Cost: \$ 30,000.00 Estimated	
Prior Year Cost: N/A	
Terms: (Annual, Multi-Year, One-Time): One-Time	

Month:(board meeting) October 2025 **Budget Administrator** Jake Slabodnik **Date** 10/7/2025



PURCHASING UNIVERSAL REQUEST

BLUE VALLEY SCHOOL DISTRICT #229

Department/Bldg.:	Human Resources	Requested By:	Dr. Eric Punswick
Purpose: (please explain in detail why we need the items or services requested)			
<p>Renewal for 2026 employee paid All State Identity Protection. No rate change for 2026.</p> <p>Cyber protection offered to employees for personal devices. Features of cyber protection include: personal computer safety, webcam protection, firewall, antivirus, browsing and phishing protection, web filtering, VPN, password manager, and network security.</p> <p>2026 renewal cost: \$10.96/employee only; \$18.96/family</p>			
Fund:	Employee paid <input type="checkbox"/>	Account Number:	
Funding Year:	2025/2026 <input type="checkbox"/>	Location(s) items or services are for:	District Wide Benefit
Does this use Bond Funds? (if yes, see below)		No <input type="checkbox"/>	
<input type="checkbox"/> This request includes extended warranty, service or maintenance. Please complete the <u>Bond Warranty Agreement Form on page 2</u>		<input type="checkbox"/> This request includes training or consultation. Please complete <u>Bond Consultant Services Form on Page 3</u>	

Check all that apply to this Purchase:

- | | |
|--|--|
| <input type="checkbox"/> This is a New Contract | <input type="checkbox"/> This is a New Bid/RFP |
| <input checked="" type="checkbox"/> This is a Renewal Contract | <input type="checkbox"/> This is a Purchase from Bid/RFP # _____ |
| <input type="checkbox"/> This is a Curriculum purchase | <input type="checkbox"/> This Purchase requires BOE Signatures |
| <input type="checkbox"/> This can be purchased off of _____ Contract # _____ | |

Begin Date: 1/1/2026	End Date: 12/31/2026
Company: Allstate Identity Protection	Street Address: 7350 N. Dobson Rd. Suite 101
Contact Name: Patrick Hickey	City: Scottsdale
Telephone: (404) 630-9396	State: AZ
Email: phickey@aip.com	Zip Code: 85256
Cost: \$ 87,173.00 Estimated	
Prior Year Cost: \$ 83,970.00 Estimated	
Terms: (Annual, Multi-Year, One-Time): Annual <input type="checkbox"/>	

Month:(board meeting) October 2025 **Budget Administrator** Dr. Eric Punswick **Date** 10/1/2025



PURCHASING UNIVERSAL REQUEST

BLUE VALLEY SCHOOL DISTRICT #229

Department/Bldg.:	Human Resources	Requested By:	Dr. Eric Punswick
Purpose: (please explain in detail why we need the items or services requested)			
<p>ARAG Legal Insurance for 1/1/2026. One monthly rate for employee and covered dependents of \$18.78 per month.</p> <p>ARAG Legal insurance provides a network attorneys for personal legal matters for employees and covered family members across a variety of needs (family, home, auto, estate planning, elder law, consumer protection, criminal situations, divorce, finance & tax, traffic & other general personal legal needs). 2026 cost: \$18.78 per month premium rate (employee and dependents). Under rate guarantee, 1/1/2025-12/31/2028. Paid for by the employee via payroll.</p>			
Fund:	Employee paid <input type="checkbox"/>	Account Number:	
Funding Year:	2025/2026 <input type="checkbox"/>	Location(s) items or services are for:	District Wide Benefit
Does this use Bond Funds? (if yes, see below)		No <input type="checkbox"/>	
<input type="checkbox"/> This request includes extended warranty, service or maintenance. Please complete the <u>Bond Warranty Agreement Form on page 2</u>		<input type="checkbox"/> This request includes training or consultation. Please complete <u>Bond Consultant Services Form on Page 3</u>	

Check all that apply to this Purchase:

- | | |
|--|--|
| <input type="checkbox"/> This is a New Contract | <input type="checkbox"/> This is a New Bid/RFP |
| <input checked="" type="checkbox"/> This is a Renewal Contract | <input type="checkbox"/> This is a Purchase from Bid/RFP # _____ |
| <input type="checkbox"/> This is a Curriculum purchase | <input type="checkbox"/> This Purchase requires BOE Signatures |
| <input type="checkbox"/> This can be purchased off of _____ Contract # _____ | |

Begin Date: 1/1/2026	End Date: 12/31/2026
Company: ARAG Legal Insurance	Street Address: 500 Grand Avenue, Suite 100
Contact Name: Nathan Steggall	City: Des Moines
Telephone: (515) 237-0263	State: IA
Email: nathan.steggall@ARAGlegal.com	Zip Code: 50309
Cost:	\$ 51,607.00
Prior Year Cost:	\$46,649.00
Terms: (Annual, Multi-Year, One-Time): Annual	<input type="checkbox"/>

Month:(board meeting) October 2025 **Budget Administrator** Dr. Eric Punswick **Date**10/1/2025



PURCHASING UNIVERSAL REQUEST

BLUE VALLEY SCHOOL DISTRICT #229

Department/Bldg.:	SPED	Requested By:	Dr. Mark Schmidt
Purpose: (please explain in detail why we need the items or services requested)			
<p>Student (FC) will be attending Brighthouse Academy for hourly transition services (up to 10 hours/week) for the 25-26 school year. This is an IEP decision.</p>			
Fund:	Special Education <input type="checkbox"/>	Account Number:	26090
Funding Year:	2025/2026 <input type="checkbox"/>	Location(s) items or services are for:	Brighthouse Academy
Does this use Bond Funds? (if yes, see below)			
<input type="checkbox"/> This request includes extended warranty, service or maintenance. Please complete the <u>Bond Warranty Agreement Form on page 2</u>		<input type="checkbox"/> This request includes training or consultation. Please complete <u>Bond Consultant Services Form on Page 3</u>	

Check all that apply to this Purchase:

- | | |
|--|--|
| <input type="checkbox"/> This is a New Contract | <input type="checkbox"/> This is a New Bid/RFP |
| <input checked="" type="checkbox"/> This is a Renewal Contract | <input type="checkbox"/> This is a Purchase from Bid/RFP # _____ |
| <input type="checkbox"/> This is a Curriculum purchase | <input type="checkbox"/> This Purchase requires BOE Signatures |
| <input type="checkbox"/> This can be purchased off of _____ Contract # _____ | |

Begin Date: 8/18/2025	End Date: 8/18/2026
Company: Brighthouse Academy LLC	Street Address: 4601 E Douglas Ave, Ste 150
Contact Name: Grant Solomon	City: Wichita
Telephone:	State: KS
Email: grantsolomon@thebighthouseacademy.com	Zip Code: 67218
Cost: \$ 25,650.00 Estimated	<input type="checkbox"/>
Prior Year Cost: n/a	
Terms: (Annual, Multi-Year, One-Time): Annual	

Month:(board meeting) October 2025 **Budget Administrator** Dr. Mark Schmidt **Date** 10/1/2025

Individual Service Agreement

This individual Service Agreement (“ISA”) is an amendment to “The Brighthouse Academy - School Contract Service Agreement” and is effective by and between Unified School District No. 229, Johnson County, State of Kansas (“Guarantor”) and The Brighthouse Academy LLC. For and in consideration of the promises, covenants and agreements herein made and contained in the current Master Contract, effective as of 8/18/2025.

1. Services Provided.

Guarantor agrees to pay The Brighthouse Academy LLC for the services marked below to be provided for [REDACTED] (student).

 Educational Services (Full-Time Student) – Monthly services are calculated based on a 201 day school year / 12 months (average of 16.75 days). Partial months are prorated at the daily rate of \$492.54, not to exceed the full-time monthly rate.

 Educational Services (Half-Day Student) - Monthly services are calculated based on a 201-day school year / 12 months (average of 16.75 days). Partial months are prorated at the daily rate of \$268.66, not to exceed the half-time monthly rate.

 X **Educational Services (Transition - Hourly Rate)** - Transition services are charged and paid at \$75.00 per hour of service provided as indicated on the IEP.

2. Contract Period.

This Contract commences on the planned admission date or contract renewal date of August 18th 2025 through August 17th 2026.

3. Rates.

The daily rates and estimated total charges are as follows:

	Days	Full-Time per Mo	Half-Time Per Month	Transition Hourly Rate per hour
Education and Related Services	201 (school year) – If ESY is not included in the IEP, the district will not be charged for June and July.	\$8,250.00	\$4,500.00	\$75.00 per hour of service provided



PURCHASING UNIVERSAL REQUEST

BLUE VALLEY SCHOOL DISTRICT #229

Department/Bldg.:		SPED	Requested By:		Dr. Mark Schmidt
Purpose: (please explain in detail why we need the items or services requested)					
Student (JR) will be attending Brightouse Academy for the remainder of the 25-26 school year. This is an IEP decision.					
Fund:	Special Education	<input type="checkbox"/>	Account Number:		26090
Funding Year:	2025/2026	<input type="checkbox"/>	Location(s) items or services are for:		Brighthouse Academy
Does this use Bond Funds? (if yes, see below)					
<input type="checkbox"/> This request includes extended warranty, service or maintenance. Please complete the <u>Bond Warranty Agreement Form on page 2</u>			<input type="checkbox"/> This request includes training or consultation. Please complete <u>Bond Consultant Services Form on Page 3</u>		

Check all that apply to this Purchase:

- | | |
|--|--|
| <input checked="" type="checkbox"/> This is a New Contract | <input type="checkbox"/> This is a New Bid/RFP |
| <input type="checkbox"/> This is a Renewal Contract | <input type="checkbox"/> This is a Purchase from Bid/RFP # _____ |
| <input type="checkbox"/> This is a Curriculum purchase | <input type="checkbox"/> This Purchase requires BOE Signatures |
| <input type="checkbox"/> This can be purchased off of _____ Contract # _____ | |

Begin Date: 10/7/2025	End Date: 8/18/2026
Company: Brighthouse Academy LLC	Street Address: 4601 E Douglas Ave, Ste 150
Contact Name: Grant Solomon	City: Wichita
Telephone:	State: KS
Email: grantsolomon@thebighthouseacademy.com	Zip Code: 67218
Cost: \$ 90,000.00 Estimated	<input type="checkbox"/>
Prior Year Cost:	n/a
Terms: (Annual, Multi-Year, One-Time): Annual	

Month:(board meeting) November 2025 **Budget Administrator** Dr. Mark Schmidt **Date** 10/6/2025

Individual Service Agreement

This individual Service Agreement (“ISA”) is an amendment to “The Brighthouse Academy - School Contract Service Agreement” and is effective by and between Unified School District No. 229, Johnson County, State of Kansas (“Guarantor”) and The Brighthouse Academy LLC. For and in consideration of the promises, covenants, and agreements herein made and contained in the current Master Contract, effective as of 8/18/2025.

1. Services Provided.

Guarantor agrees to pay The Brighthouse Academy LLC for the services marked below to be provided for [REDACTED] (student).

X **Educational Services (Full-Time Student)** – Monthly services are calculated based on a 201 day school year / 12 months (average of 16.75 days). Partial months are prorated at the daily rate of \$492.54, not to exceed the full-time monthly rate.

 Educational Services (Half-Day Student) - Monthly services are calculated based on a 201-day school year / 12 months (average of 16.75 days). Partial months are prorated at the daily rate of \$268.66, not to exceed the half-time monthly rate.

 Educational Services (Transition - Hourly Rate) - Transition services are charged and paid at \$75.00 per hour of service provided as indicated on the IEP.

2. Contract Period.

This Contract commences on the planned admission date or contract renewal date of August 18th 2025 through August 18th 2026.

3. Rates.

The daily rates and estimated total charges are as follows:

	Days	Full-Time per Mo	Half-Time Per Month	Transition Hourly Rate per hour
Education and Related Services	201 (school year) – If ESY is not included in the IEP, the district will not be charged for June and July.	\$8,250.00	\$4,500.00	\$75.00 per hour of service provided



PURCHASING UNIVERSAL REQUEST

BLUE VALLEY SCHOOL DISTRICT #229

Department/Bldg.:	Human Resources	Requested By:	Dr. Eric Punswick
Purpose: (please explain in detail why we need the items or services requested)			
Voluntary retirement savings plans - 403 (b) Plan and 457(b) Plans Servicing Agreement, effective 1/1/2026. Employee paid fees via plan enrollment.			
Fund:	Employee Paid	Account Number:	
Funding Year:	2025/2026 ▼	Location(s) items or services are for:	District Wide Benefit
Does this use Bond Funds? (if yes, see below)		No ▼	
<input type="checkbox"/> This request includes extended warranty, service or maintenance. Please complete the <u>Bond Warranty Agreement Form on page 2</u>		<input type="checkbox"/> This request includes training or consultation. Please complete <u>Bond Consultant Services Form on Page 3</u>	

Check all that apply to this Purchase:

- | | |
|--|--|
| <input type="checkbox"/> This is a New Contract | <input type="checkbox"/> This is a New Bid/RFP |
| <input checked="" type="checkbox"/> This is a Renewal Contract | <input type="checkbox"/> This is a Purchase from Bid/RFP # _____ |
| <input type="checkbox"/> This is a Curriculum purchase | <input type="checkbox"/> This Purchase requires BOE Signatures |
| <input type="checkbox"/> This can be purchased off of _____ Contract # _____ | |

Begin Date: 1/1/2026	End Date: 12/31/2026
Company: CBIZ Benefits and Insurance Services	Street Address: 700 West 47th Street, Suite 1100
Contact Name: Cindy Orr	City: Kansas City
Telephone: (816) 945-5199	State: MO
Email: corr@cbiz.com	Zip Code: 64112
Cost:	\$ 78,170.00
Prior Year Cost:	\$ 74,371.00 Estimated
Terms: (Annual, Multi-Year, One-Time): Annual	▼

Month:(board meeting) October 2025 **Budget Administrator** Dr. Eric Puswick **Date** 10/1/2025



PURCHASING UNIVERSAL REQUEST

BLUE VALLEY SCHOOL DISTRICT #229

Department/Bldg.:	Custodial	Requested By:	Matt Brooks
Purpose: (please explain in detail why we need the items or services requested)			
To fulfill contractor painting needs in the district. This is outside the scope of patch and paint repair needs in the District (which was on RFQ 24019).			
Fund:	Capital Outlay	Account Number:	31422
Funding Year:	2025/2026	Location(s) items or services are for:	Various Buildings
Does this use Bond Funds? (if yes, see below)		No	
<input type="checkbox"/> This request includes extended warranty, service or maintenance. Please complete the <u>Bond Warranty Agreement Form on page 2</u>		<input type="checkbox"/> This request includes training or consultation. Please complete <u>Bond Consultant Services Form on Page 3</u>	

Check all that apply to this Purchase:

- | | |
|--|--|
| <input type="checkbox"/> This is a New Contract | <input type="checkbox"/> This is a New Bid/RFP |
| <input type="checkbox"/> This is a Renewal Contract | <input type="checkbox"/> This is a Purchase from Bid/RFP # _____ |
| <input type="checkbox"/> This is a Curriculum purchase | <input type="checkbox"/> This Purchase requires BOE Signatures |
| <input type="checkbox"/> This can be purchased off of _____ Contract # _____ | |

Begin Date: 7/1/2025	End Date: 6/30/2026
Company: Fritz Painting & Drywall LLC	Street Address: PO Box 818
Contact Name: Jack Fritz	City: Olathe
Telephone: (913) 782-4655	State: KS
Email: jack@fritzpainting.com	Zip Code: 66061
Cost: \$ 50,000.00 Estimated	
Prior Year Cost: \$95,481.00	
Terms: (Annual, Multi-Year, One-Time): Annual	

Month:(board meeting) October 2025 **Budget Administrator** Matt Brooks **Date** 10/2/2025



PURCHASING UNIVERSAL REQUEST

BLUE VALLEY SCHOOL DISTRICT #229

Department/Bldg.:	SPED	Requested By:	Mark Schmidt
Purpose: (please explain in detail why we need the items or services requested)			
By purchasing 3 SMARTS CONNECT HS and 3 SMARTS CONNECT MS site licenses allows for 1 common login to access SMARTS CONNECT MS and 1 common login to access SMARTS CONNECT HS. This login to be used by any and all MS and HS Special Education Staff in the District. The institutional licenses allow for multiple simultaneous log-ins.			
Fund:	Special Education	Account Number:	45006735-0
Funding Year:	2025/2026	Location(s) items or services are for:	Multiple
Does this use Bond Funds? (if yes, see below)		No	
<input type="checkbox"/> This request includes extended warranty, service or maintenance. Please complete the <u>Bond Warranty Agreement Form on page 2</u>		<input type="checkbox"/> This request includes training or consultation. Please complete <u>Bond Consultant Services Form on Page 3</u>	

Check all that apply to this Purchase:

- | | |
|--|--|
| <input checked="" type="checkbox"/> This is a New Contract | <input type="checkbox"/> This is a New Bid/RFP |
| <input type="checkbox"/> This is a Renewal Contract | <input type="checkbox"/> This is a Purchase from Bid/RFP # _____ |
| <input type="checkbox"/> This is a Curriculum purchase | <input type="checkbox"/> This Purchase requires BOE Signatures |
| <input type="checkbox"/> This can be purchased off of _____ Contract # _____ | |

Begin Date: 7/1/2025	End Date: 6/30/2028
Company: Research Institute for Learning and Development	Street Address: 4 Militia Drive, Ste 20
Contact Name: Lindsay Pietro	City: Lexington
Telephone: (781) 402-9301	State: MA
Email: lpietro@researchchild.org	Zip Code: 02421
Cost: \$ 53,970.00 Estimated	
Prior Year Cost: N/A	
Terms: (Annual, Multi-Year, One-Time): Multi-Year	

Month:(board meeting) October 2025 **Budget Administrator** Dr. Mark Schmidt **Date** 9/17/2025



Research Institute for
Learning and Development

Company Address 4 Militia Drive, Suite 20
Lexington, Massachusetts 02421
United States

Created Date 9/9/2025
Expiration Date 10/9/2025
Quote Number 00003427

Prepared By Lindsay Pietro
Phone (781) 402-9301
Email lpietro@researchchild.org

Contact Name Mark Schmidt

Bill To Name Blue Valley Schools
Bill To 15020 Metcalf Ave.
Overland Park, Kansas 66223
United States

Ship To Name Blue Valley Schools
Ship To United States

Description Site licenses (1 SMARTS CONNECT HS and 1 SMARTS CONNECT MS) allow for 1 common login to access SMARTS CONNECT MS and 1 common login to access SMARTS CONNECT HS. This login to be used by any and all MS and HS Special Education Staff in the District. The institutional licenses allow for multiple simultaneous log-ins.

Terms of use for site licenses are that only special educator staff will be using the program – general staff is not included and may not have access any of the resources.

Money already paid (\$38,220) from Clinic license quote #3171 has been applied to total cost of site license.

Pricing locked in for 3-year contract, with discount applied for years 2 and 3.

Licenses active from July 1, 2025-June 30, 2026;
July 1, 2026-June 30, 2027;
July 1, 2027-June 30, 2028.

Product	List Price	Quantity	Sales Price	Total Price
SMARTS CONNECT HS Site License	\$7,000.00	1.00	\$2,750.00	\$2,750.00
SMARTS CONNECT HS Site License	\$7,000.00	1.00	\$2,625.00	\$2,625.00
SMARTS CONNECT HS Site License	\$7,000.00	1.00	\$2,500.00	\$2,500.00
SMARTS CONNECT MS Site License	\$7,500.00	1.00	\$2,750.00	\$2,750.00
SMARTS CONNECT MS Site License	\$7,500.00	1.00	\$2,625.00	\$2,625.00
SMARTS CONNECT MS Site License	\$7,500.00	1.00	\$2,500.00	\$2,500.00

Grand Total

\$15,750.00



This quote is subject to the attached Terms and Conditions

EACH TEACHER/PROFESSIONAL WHO USES THE SMARTS CURRICULUM AND/OR METACOG SURVEY MUST HAVE THEIR OWN LICENSE ASSIGNED BY RESEARCHILD. LICENSES MAY NOT BE SHARED OR USED BY MORE THAN ONE EDUCATOR.

SMARTS Curriculum and MetaCOG Online licenses are effective for one year and must be renewed annually.

ResearchILD is a 501(c)(3) not-for-profit organization that relies on license fees from the SMARTS curriculum to help support the ongoing costs of developing programs/materials to help students with executive function challenges succeed.

ResearchILD offers special packages for schools that purchase 10 or more licenses, which include: savings on annual license fees; discounts for workshops and conferences; and access to professional development training, coaching, and other resources.

***This quote reflects current pricing and is valid for 30 days from the date of issue.
Prices subject to change.***

TERMS AND CONDITIONS

- I. Scheduling, Materials and Set-up.
 - A. Customer agrees to work in good faith with ResearchILD to schedule dates for professional development, trainings, coaching and/or other consulting services ("Professional Development") within 30 days of the execution of this quote "Agreement". Unless specifically agreed to in writing, all Professional Development services must be completed within the 12 months following the execution date of this Agreement.
 - B. If applicable, Customer is responsible for duplication of hand-outs and providing room set-up as requested by ResearchILD, including projector, easel/whiteboard, etc.
- II. Payment.
 - A. Unless otherwise agreed in writing, payment for SMARTS Licenses, Professional Development (the "Services") and any other costs specified herein are due upon execution of this Agreement (e.g., purchase order due upon signing).
 - B. If applicable, a fixed travel fee shall be included for Services to be provided in person. In the event actual travel expenses exceed the fixed travel fee, Customer shall be responsible for reimbursing such additional expenses upon receipt of invoice from ResearchILD.
 - C. Delivery of online curriculum licenses is complete upon issuance of log-in credentials to Customer.
 - D. All payments are due within 30 days of receipt of invoice. ResearchILD accepts payment by check or electronic funds transfer. For payments made by credit card or other method, an additional processing fee will be applied.
 - E. ResearchILD reserves the right to charge interest on any overdue payments of fees and other amounts required to be paid by Customer. Such interest shall accrue at a rate of one and one-half percent (1½%) per month and Customer shall pay ResearchILD's costs of collection including ResearchILD's reasonable attorney fees and court costs.
- III. Ownership. Customer acknowledges and agrees that the SMARTS Executive Function Curriculum, MetaCOG Online Surveys and the contents of Professional Development trainings, including but not limited to the slides, hand-outs, publications, SMARTS curriculum materials, explanations and worksheets ("Training Materials") are the exclusive property of ResearchILD.
 - A. The Training Materials may be used solely for distribution to the participants of the Professional Development program and coaching/consultation activities. The Training Materials are provided for instructional purposes only and Customer acknowledges and agrees that neither Customer nor training participants shall have any rights to use, distribute, or grant others the right to use the Training Materials for any other purpose or in any other form without the express written permission of ResearchILD.
 - B. Customer acknowledges and agrees that the SMARTS Executive Function Curriculum and/or Training Materials may only be used by someone who has an up-to-date, fully paid SMARTS license as described in and subject to the Terms of Use in Attachment A, which is hereby attached and incorporated into these Terms and Conditions.
 - C. Customer agrees that Professional Development training sessions may not be videotaped and/or recorded without the express written permission of ResearchILD.
- IV. Termination. Either Party may terminate the Services if the other party materially defaults in its obligations hereunder and fails to cure such default within fifteen (15) days after receiving written notice of the default. In the event of termination for any reason the Customer agrees that ResearchILD shall be paid its fees and expenses for the completed Services and any expenses associated with the cancellation of training dates. The following provisions survive termination of the Services for any reason: Section III (Ownership), and Section V (Limitation of Liability; Exclusion of Damages), Attachment A (SMARTS Executive Function Curriculum Terms of Use).



V. Limitation of Liability; Exclusion of Damages. In no event will ResearchILD be liable to Customer or any third party for any direct, incidental, consequential, special, indirect, punitive, or exemplary damages including damages for loss of business, loss of profits, loss of goodwill or business reputation, business interruption, loss of data, loss of business information and damages that result from the provision of Services, even if ResearchILD has been advised of the possibility of such damages or losses. In any event, regardless of the form of the action, arising in any way in connection with this agreement, for any cause whatsoever is limited to payment of direct damages in an amount not to exceed \$250.

Attachment A- SMARTS Executive Function Curriculum Terms of Use

The SMARTS program, including but not limited to the SMARTS Secondary, SMARTS Premium, SMARTS CONNECT, SMARTS Elementary, SMARTS @Home and MetaCOG Survey and Toolkit curriculum products: student workbooks; and all related training, lectures, presentations, research findings, publications, concepts, ideas, exercises, graphics, explanations, and/or all materials available via ResearchILD's Websites and any and all other formats are the exclusive property of ResearchILD. Hereinafter all such materials will be referred to as the "SMARTS Curriculum" or "SMARTS".

1. Only an authorized individual(s) may utilize the SMARTS Curriculum, an authorized individual ("LICENSEE") is someone who has an up-to-date, fully paid individual, clinic, or school license to use the specified curriculum product(s), (i.e., SMARTS Secondary, SMARTS Elementary and/or MetaCOG). Licenses are effective for one year from the date of issue and must be renewed on an annual basis.
2. To access the specified SMARTS Curriculum product, each LICENSEE must have an individual license assigned by ResearchILD via a unique LICENSEE name and password. If the license is purchased by a school or other organization on behalf of a LICENSEE, the license may be reassigned to another LICENSEE during the license term by contacting ResearchILD to cancel access and request a new LICENSEE name and password.
3. SMARTS Curriculum licenses may not be shared or used by more than one LICENSEE. The SMARTS Curriculum may be used solely for LICENSEE'S students and/or clients. SMARTS may not be distributed, shared, copied or made available for use by anyone other than the authorized LICENSEE. If the LICENSEE has a license assigned by LICENSEE'S school or other organization, SMARTS may be utilized solely for such school's/organization's students. The school/organization that purchased the license(s) is responsible for ensuring all LICENSEES are made aware of and comply with these Intellectual Property terms.
4. LICENSEE may not utilize the SMARTS Curriculum in the following manner without specific written permission from ResearchILD:
 - With students and/or clients as part of an on-line education program, virtual school, or any other remote access program or service with the following exception. Subject to the other Terms of Use included herein, a LICENSEE may upload SMARTS Materials to their own electronic classroom for use with their students.
 - As part of a training program or course for teachers, psychologists, educational therapists and/or any other professions.
 - Any other manner not expressly permitted under these Terms of Use.
5. Use of the SMARTS materials is subject to the Terms of Use described herein. By using any or all of the SMARTS materials, LICENSEE is acknowledging that LICENSEE has read, understood and agreed to be bound by these Terms of Use. If LICENSEE does not agree to these Terms of Use, LICENSEE should not utilize the materials.
6. SMARTS materials may only be utilized in their original form with all trademarks, logos and intellectual property language intact. Any permitted use of SMARTS content not in its original form must be clearly identified and have the following reference language included in a visible location: "©2014-2024 ResearchILD. All rights reserved. Use is by permission only."
7. LICENSEE may not: a) modify, b) make improvements, and/or c) create derivative works or adjusted versions of SMARTS (hereinafter referred to as "Modifications") without written permission from ResearchILD. In the event that LICENSEE makes Modifications to SMARTS, LICENSEE hereby acknowledges and agrees that such Modifications: a) must immediately be provided to ResearchILD and b) shall become the exclusive property of ResearchILD. LICENSEE does not retain any ownership or other rights in the Modifications except for the limited, non-transferable license to use the Modifications in accordance with these Terms of Use. Notwithstanding the foregoing, LICENSEE may customize individual handouts or slides for use with LICENSEE'S students/clients only.

***Any questions about these Terms of Use or requests for further information should be directed to
ResearchILD 4 Militia Drive, Suite 20, Lexington, MA 02421, Telephone: 781-861-3711.***



PURCHASING UNIVERSAL REQUEST

BLUE VALLEY SCHOOL DISTRICT #229

Department/Bldg.:	Grounds	Requested By:	Caleb Clements
Purpose: (please explain in detail why we need the items or services requested)			
Parking lot snow removal services as needed through December 31, 2025.			
Fund:	Capital Outlay ▼	Account Number:	32900
Funding Year:	2025/2026 ▼	Location(s) items or services are for:	District Wide
Does this use Bond Funds? (if yes, see below)		No	
<input type="checkbox"/> This request includes extended warranty, service or maintenance. Please complete the <u>Bond Warranty Agreement Form on page 2</u>		<input type="checkbox"/> This request includes training or consultation. Please complete <u>Bond Consultant Services Form on Page 3</u>	

Check all that apply to this Purchase:

- | | |
|--|--|
| <input type="checkbox"/> This is a New Contract | <input type="checkbox"/> This is a New Bid/RFP |
| <input type="checkbox"/> This is a Renewal Contract | <input type="checkbox"/> This is a Purchase from Bid/RFP # _____ |
| <input type="checkbox"/> This is a Curriculum purchase | <input type="checkbox"/> This Purchase requires BOE Signatures |
| <input type="checkbox"/> This can be purchased off of _____ Contract # _____ | |

Begin Date: 10/1/2025	End Date: 12/31/2025
Company: Signature Landscape LLC	Street Address: 15705 Pflumm
Contact Name: Joe Bond	City: Olathe
Telephone: (913) 829-8181	State: KS
Email: joe@signaturekc.com	Zip Code: 66062
Cost: \$ 30,000.00 Estimated	▼
Prior Year Cost:	
Terms: (Annual, Multi-Year, One-Time):	

Month:(board meeting) October 2025 **Budget Administrator** Jacob Slobodnik **Date**9/29/2025



PURCHASING UNIVERSAL REQUEST

BLUE VALLEY SCHOOL DISTRICT #229

Department/Bldg.:	Human Resources	Requested By:	Dr. Eric Punswick
Purpose: (please explain in detail why we need the items or services requested)			
<p>Submission of The Standard 2026 insurance policy for short-term disability and long-term disability.</p> <p>2026 STD renewal cost \$391,502 - 23% rate increase</p> <p>2026 LTD renewal cost \$38,831 - no rate increase</p>			
Fund:	Special Reserve Healthcare	Account Number:	048-8914
Funding Year:	2025/2026 ▼	Location(s) items or services are for:	District Wide Benefit
Does this use Bond Funds? (if yes, see below)		No ▼	
<input type="checkbox"/> This request includes extended warranty, service or maintenance. Please complete the <u>Bond Warranty Agreement Form on page 2</u>		<input type="checkbox"/> This request includes training or consultation. Please complete <u>Bond Consultant Services Form on Page 3</u>	

Check all that apply to this Purchase:

- | | |
|--|--|
| <input type="checkbox"/> This is a New Contract | <input type="checkbox"/> This is a New Bid/RFP |
| <input checked="" type="checkbox"/> This is a Renewal Contract | <input type="checkbox"/> This is a Purchase from Bid/RFP # _____ |
| <input type="checkbox"/> This is a Curriculum purchase | <input type="checkbox"/> This Purchase requires BOE Signatures |
| <input type="checkbox"/> This can be purchased off of _____ Contract # _____ | |

Begin Date: 1/1/2026	End Date: 12/31/2026
Company: The Standard Insurance Company	Street Address: 7500 College Blvd., Suite 750
Contact Name: Sherri Borgmeyer	City: Overland Park
Telephone: (913) 266-0219	State: KS
Email: sherri.borgmeyer@standard.com	Zip Code: 66210
Cost: \$ 430,333.00 Estimated	
Prior Year Cost: \$ 356,766.00 Estimated	
Terms: (Annual, Multi-Year, One-Time): Annual ▼	

Month:(board meeting) October 2025 **Budget Administrator** Dr. Eric Puswick **Date** 10/1/2025



PURCHASING UNIVERSAL REQUEST

BLUE VALLEY SCHOOL DISTRICT #229

Department/Bldg.:		SPED		Requested By:		Dr. Mark Schmidt	
Purpose: (please explain in detail why we need the items or services requested)							
<p>1) SLP to cover for maternity leave at WSE 8/10-10/15/25 2) Newly added vacancy at HES from 10/17-12/19/25</p> <p>Original amount: \$36,000 Increase needed: \$29,000 Total revised amount: \$65,000</p>							
Fund:	Special Education ▼			Account Number:		30260	
Funding Year:	2025/2026 ▼			Location(s) items or services are for:		WSE/HES	
Does this use Bond Funds? (if yes, see below)				No			
<input type="checkbox"/> This request includes extended warranty, service or maintenance. Please complete the <u>Bond Warranty Agreement Form on page 2</u>				<input type="checkbox"/> This request includes training or consultation. Please complete <u>Bond Consultant Services Form on Page 3</u>			

Check all that apply to this Purchase:

- | | |
|--|--|
| <input type="checkbox"/> This is a New Contract | <input type="checkbox"/> This is a New Bid/RFP |
| <input checked="" type="checkbox"/> This is a Renewal Contract | <input type="checkbox"/> This is a Purchase from Bid/RFP # _____ |
| <input type="checkbox"/> This is a Curriculum purchase | <input type="checkbox"/> This Purchase requires BOE Signatures |
| <input type="checkbox"/> This can be purchased off of _____ Contract # _____ | |

Begin Date: 8/10/2025	End Date: 12/19/2025
Company: Supplemental Health Care Services	Street Address: 6955 S Union Park Center Ste 400
Contact Name: Cahty Rigby	City: Cottonwood Heights
Telephone: (866) 474-6677	State: UT
Email: crigby@shccares.com	Zip Code: 84047
Cost: \$ 65,000.00 Estimated	▼
Prior Year Cost:	
Terms: (Annual, Multi-Year, One-Time): Annual	▼

Month:(board meeting) October 2025 **Budget Administrator** Dr. Mark Schmidt **Date**10/3/2025



PURCHASING UNIVERSAL REQUEST

BLUE VALLEY SCHOOL DISTRICT #229

Department/Bldg.:	Human Resources	Requested By:	Dr. Eric Punswick
Purpose: (please explain in detail why we need the items or services requested)			
<p>2026 Employee paid group vision insurance contract and renewal letter with Surency Life and Health.</p> <p>No rate changes</p>			
Fund:	Employee paid ▼	Account Number:	
Funding Year:	2025/2026 ▼	Location(s) items or services are for:	District Wide Benefit
Does this use Bond Funds? (if yes, see below)		No ▼	
<input type="checkbox"/> This request includes extended warranty, service or maintenance. Please complete the <u>Bond Warranty Agreement Form on page 2</u>		<input type="checkbox"/> This request includes training or consultation. Please complete <u>Bond Consultant Services Form on Page 3</u>	

Check all that apply to this Purchase:

- | | |
|--|--|
| <input type="checkbox"/> This is a New Contract | <input type="checkbox"/> This is a New Bid/RFP |
| <input checked="" type="checkbox"/> This is a Renewal Contract | <input type="checkbox"/> This is a Purchase from Bid/RFP # _____ |
| <input type="checkbox"/> This is a Curriculum purchase | <input type="checkbox"/> This Purchase requires BOE Signatures |
| <input type="checkbox"/> This can be purchased off of _____ Contract # _____ | |

Begin Date: 1/1/2026	End Date: 12/31/2029
Company: Surency Life & Health Insurance Co	Street Address: 11300 Tomahawk Creek Prkwy-St 350 #
Contact Name: Erin Baker	City: Leawood
Telephone: (913) 906-9373	State: KS
Email: ebaker@deltadentalks.com	Zip Code: 66211
Cost: \$ 317,190.00 Estimated	
Prior Year Cost: \$305,905.00 Estimated	
Terms: (Annual, Multi-Year, One-Time): Annual ▼	

Month:(board meeting) October 2025 **Budget Administrator** Dr. Eric Punswick **Date**10/1/2025



PO Box 789773, Wichita, KS 67278-9773
(866) 818-8805

March 12, 2025

ERIN PUNSWICK
U S D #229 – BLUE VALLEY
15020 METCALF
OVERLAND PARK KS 66283-0901

RE: Surency Renewal of Group Vision
Group #1698-0

Dear Erin Punswick:

We consider it both a pleasure and a great opportunity to serve you and your employees with the Surency Vision product under the Surency Life & Health umbrella. Your contract with Surency will renew on **January 1, 2026**.

Effective with your **January 1, 2026** Surency vision renewal, your rates will be as follows:

	<u>Current Rates:</u>	<u>New Rates:</u>	
Employee:	\$10.30	\$10.30	No Increase
Employee + Spouse:	\$18.14	\$18.14	No Increase
Employee + Child(ren):	\$17.02	\$17.02	No Increase
Family:	\$30.38	\$30.38	No Increase

NOTE: New 4yr Agreement:
2026 – No Increase
2027 – No Increase
2028 – No Increase
2029 – 5% Rate Cap

A policy endorsement is enclosed to indicate your acceptance of this renewal. Please sign and return the endorsement via fax to 316.462.3329, or email to marketing@surency.com. **This endorsement must be returned by December 1, 2025 to ensure timely submission of your group’s renewal.** Please attach a signed copy of the endorsement to your current contract. **If the signed endorsement is not returned prior to your renewal date shown above, your group will be re-enrolled in the current plan being administered with the new rates noted above.**

We look forward to the continued opportunity to be of service to you and your employees. If you have any questions regarding your renewal, please feel free to contact me.

Sincerely,

Erin Baker
Director of Sales, Services & Analytics

EB:as

Enclosure

cc: Holmes Murphy & Associates LLC



surency.com



VISION RENEWAL ADDENDUM
FOR GROUP #1698-0

Attached to and forming a part of the Agreement To Provide Vision Care Benefits between U S D #229 - BLUE VALLEY (Plan #1698-0) and Surency Life & Health.

It is agreed and understood that effective with the January 1, 2026 renewal, Section I, Number 4 shall read:

RATES:

Table with 2 columns: Category (Employee, Employee + Spouse, Employee + Child(ren), Family) and Rate (\$10.30, \$18.14, \$17.02, \$30.38)

NOTE: New 4yr Agreement:
2026 - No Increase
2027 - No Increase
2028 - No Increase
2029 - 5% Rate Cap

Administrative Contact: Dr. Jennifer Spencer - Director of Human Resources for Employee Benefits (jdspencer02@bluevalleyk12.org)

Please acknowledge acceptance of this renewal by signing below and returning the renewal confirmation by fax to 316.462.3329 or by email to marketing@surency.com by December 1, 2025.

Unified School District No. 229
Johnson County, State of Kansas
(Plan Sponsor)

Surency Life & Health
(Administrator)

By: _____
President, Board of Education

Sara K. Matlock

By: _____

Date: _____

Attested by:

Title: Senior Underwriter, Data Analyst

Clerk, Board of Education
Approved as to Form:

Date: March 12, 2025

Attorney, Board of Education



PURCHASING UNIVERSAL REQUEST

BLUE VALLEY SCHOOL DISTRICT #229

Department/Bldg.:	Blue Valley North Dance	Requested By:	Brevin Armstrong
Purpose: (please explain in detail why we need the items or services requested)			
<p>The BVN Dance Team will attend the NDA National Championships in Orlando, FL from 2/12-17/26. They will compete at the highest level of dance in the nation. Costs include room/board, meals, airfare, and ground transportation.</p> <p>Estimated costs:</p> <p>Varsity Spirit/National Dance Alliance (Registration/Lodging): ~\$19,700.00 (final prices have yet to be released)</p> <p>Southwest Airlines: \$7296.48</p> <p>Happy Limo: \$1500</p> <p>Meals: ~\$3000</p>			
Fund:	Activity Funds	Account Number:	5215232
Funding Year:	2025/2026 <input type="checkbox"/>	Location(s) items or services are for:	
Does this use Bond Funds? (if yes, see below)		No <input type="checkbox"/>	
<input type="checkbox"/> This request includes extended warranty, service or maintenance. Please complete the <u>Bond Warranty Agreement Form on page 2</u>		<input type="checkbox"/> This request includes training or consultation. Please complete <u>Bond Consultant Services Form on Page 3</u>	

Check all that apply to this Purchase:

- | | |
|--|--|
| <input checked="" type="checkbox"/> This is a New Contract | <input type="checkbox"/> This is a New Bid/RFP |
| <input type="checkbox"/> This is a Renewal Contract | <input type="checkbox"/> This is a Purchase from Bid/RFP # _____ |
| <input type="checkbox"/> This is a Curriculum purchase | <input type="checkbox"/> This Purchase requires BOE Signatures |
| <input type="checkbox"/> This can be purchased off of _____ Contract # _____ | |

Begin Date: 2/12/2026	End Date: 2/17/2026
Company: Varsity Spirit / Southwest Airlines	Street Address:
Contact Name: Brevin Armstrong	City:
Telephone: (610) 931-5679	State:
Email: barmstrong@bluevalleyk12.org	Zip Code:
Cost: \$ 33,000.00 Estimated	
Prior Year Cost: 33,388.26 Estimated	
Terms: (Annual, Multi-Year, One-Time): One-Time <input type="checkbox"/>	

Month:(board meeting) October 2025 **Budget Administrator** Matt Ortman **Date** 10/8/2025



PURCHASING UNIVERSAL REQUEST

BLUE VALLEY SCHOOL DISTRICT #229

Department/Bldg.:	Facilities and Operations	Requested By:	Jake Slobodnik
Purpose: (please explain in detail why we need the items or services requested)			
<p>This agreement is between Blue Valley School District and the water utility company, WaterOne, to establish a permanent easement at Wolf Springs Middle School along 175th street for future water line development.</p>			
Fund:	N/A	Account Number:	N/A
Funding Year:	2025/2026	Location(s) items or services are for:	WSM
Does this use Bond Funds? (if yes, see below)		No	
<input type="checkbox"/> This request includes extended warranty, service or maintenance. Please complete the <u>Bond Warranty Agreement Form on page 2</u>		<input type="checkbox"/> This request includes training or consultation. Please complete <u>Bond Consultant Services Form on Page 3</u>	

Check all that apply to this Purchase:

- | | |
|--|--|
| <input checked="" type="checkbox"/> This is a New Contract | <input type="checkbox"/> This is a New Bid/RFP |
| <input type="checkbox"/> This is a Renewal Contract | <input type="checkbox"/> This is a Purchase from Bid/RFP # _____ |
| <input type="checkbox"/> This is a Curriculum purchase | <input type="checkbox"/> This Purchase requires BOE Signatures |
| <input type="checkbox"/> This can be purchased off of _____ Contract # _____ | |

Begin Date: 10/13/2025	End Date:
Company: Water District No. 1 of Johnson County	Street Address: 10747 Renner Boulevard
Contact Name:	City: Lenexa
Telephone:	State: KS
Email:	Zip Code: 66219-9624
Cost:	\$ 0.00
Prior Year Cost:	N/A
Terms: (Annual, Multi-Year, One-Time): One-Time	

Month:(board meeting) October 2025 **Budget Administrator** J Slobodnik **Date** 9/22/2025

GRANT OF A PERMANENT EASEMENT

KNOW ALL BY THESE PRESENTS that **UNIFIED SCHOOL DISTRICT NO. 229**, the Grantor herein, for and in consideration of the sum of One Dollar (\$1.00), the receipt whereof is hereby acknowledged, and other good and valuable considerations, including the installation of a public water main, does by these presents grant and convey unto **WATER DISTRICT NO. 1 OF JOHNSON COUNTY (KANSAS)**, a quasi-municipal corporation, the Grantee herein, its successors and assigns, a permanent easement and right-of-way, across, over, and under the following described land, to wit:

A strip of land 20.00 feet in width across Tracts A, B, and Lot 1 adjoining the right of way line of 175th Street, as now established, all being in "BLUE VALLEY MIDDLE SCHOOL #11", a subdivision of land in the City of Overland Park, Johnson County, Kansas.

The rights reserved to Water District No. 1 of Johnson County (Kansas) as the Grantee herein, and hereinafter called the "DISTRICT" and the rights reserved to the Grantor are as follows, to wit:

The DISTRICT, its successors and assigns, shall have the right to perpetually survey and test soil conditions; to excavate, fill, regrade, construct, rebuild, remove and relocate within said easement water distribution or transmission main or mains and all related equipment, together with the right of access to and from such easement for its employees, agents, contractors, vehicles, materials and equipment. The DISTRICT shall have the right to remove, trim and clear away any interfering trees, rocks, shrubs, roots, limbs or surfacing materials, but within a reasonable time after completion of any such activity by the DISTRICT it shall completely fill and sufficiently tamp any excavation

to an appropriate elevation to prevent settling, with any fence or improved surface restored to its former condition, grass areas reseeded and any cultivated, established lawn resodded, without the obligation of maintenance, all surplus soil, rock and debris completely removed from the premises, and compensation paid for any damages caused to growing crops.

Except for the "zone of non-interference" as hereinafter defined, the rights of the DISTRICT shall be non-exclusive in the following respects:

The Grantor, its licensees, tenants, lienholders, other easement holders, and the successors and assigns of the Grantor, may cultivate and fully use and enjoy the land within the easement, provided that such use shall not interfere with or jeopardize the construction, installation, maintenance, repair, operation, final grade or other activities of the DISTRICT granted or authorized by the terms of this Grant, and further provided that no permanent above-ground or subterranean structures, materials, stockpiling, or building shall be erected, constructed or stored on the easement, except that non municipal improvements such as roads, drives, parking lots (subject to limitations set forth herein), drainage facilities, whether paved or otherwise surfaced curbs, walks, overhead utility wires, underground utility conduit, pipes and sewers which are non-conflicting and outside of the zone of non-interference, and fences crossing at approximately right angles may be constructed, maintained and utilized by the Grantor, its licensees, tenants, lienholders and other easement holders, and the successors and assigns of the Grantor. In the event of parking lot construction in the easement area, dedicated parking spaces or areas within five (5) feet horizontally from the water main as constructed are prohibited.

In the event future public right-of-way expands over the easement described herein and the public entity expanding the right-of-way declines to relocate DISTRICT facilities outside an area of public improvements such as extensive landscaping, paving, private streets and other extraordinary improvements, the DISTRICT shall not be obligated to restore any existing aboveground improvements or aboveground improvements hereafter installed or constructed by public entity, its licensees, tenants, other easement holders, or the successors and assigns of public entity.

The rights of the DISTRICT shall be exclusive within the "zone of non-interference" defined as that subterranean area immediately adjoining each of the DISTRICT'S mains of a pipe size of sixteen (16) inches and smaller comprising a rectangular corridor along the variable course of the pipe extending vertically from two (2) feet below the pipe perimeter bottom, and two (2) feet horizontally from both lateral sides of the pipe perimeter, as installed. For mains of pipe sizes larger than sixteen (16) inches, the "zone of non-interference" is defined as that subterranean area immediately adjoining each such main comprising a rectangular corridor along the variable course

of the pipe extending vertically from two (2) feet below the pipe perimeter bottom and four (4) feet horizontally from both lateral sides of the pipe perimeter, as installed. In the case of multiple pipes within the same easement where the zones of non-interference are contiguous or overlap, the outer boundaries of such contiguous or overlapping zones comprise an enlarged single zone. No excavations or installations of any kind shall be made by any utility or other excavator or installer within such zone of non-interference without the prior express written consent of the DISTRICT.

After completion of the initial construction of its water distribution or transmission main or mains, the DISTRICT, in exercising any right whatsoever herein acquired, may temporarily excavate or cut through any road, drive, surface, fence, curb, walk or other structure permitted herein, but shall as soon as reasonably possible replace and repair such fence or improved surface or other permitted structure to its former condition without the obligation of maintenance, reseed grass areas and resod cultivated, established lawn, and shall pay to the owner or its tenants, compensation for any damage caused to growing crops. The DISTRICT may also require the owner of any other permitted future structure or conduit, whether located above or below the ground surface within the easement, to adjust, move, support or protect such structure or conduit to permit the DISTRICT to exercise its rights herein acquired, but free of expense to the DISTRICT.

TO HAVE AND TO HOLD, unto the said DISTRICT, its successors and assigns with all of the rights, privileges, appurtenances, and immunities thereto appertaining and belonging so long as used for the purposes herein described.

IN WITNESS WHEREOF, the said Grantor has executed this instrument this _____ day of _____, 20____.

UNIFIED SCHOOL DISTRICT NO. 229

Jan Kessinger, President Board of Education

Attest:

Approved as to form:

Anna Sweeney, Board Clerk

Melissa Hillman, Board Attorney

ACKNOWLEDGEMENT

STATE OF KANSAS)
)ss:
COUNTY OF JOHNSON)

BE IT REMEMBERED, that on this _____ day of _____, 20____, before me, the undersigned, a Notary Public in and for the County and State aforesaid, personally appeared Jan Kessinger and Anna Sweeney, on behalf of **UNIFIED SCHOOL DISTRICT NO. 229**, who are personally known to me to be the same persons who executed the foregoing instrument of writing, and duly acknowledged the execution of the same.

IN WITNESS WHEREOF, I have hereunto set my hand and affixed my official seal the day and year first above written.

NOTARY PUBLIC SIGNATURE

PLEASE PRINT NAME

My appointment expires:

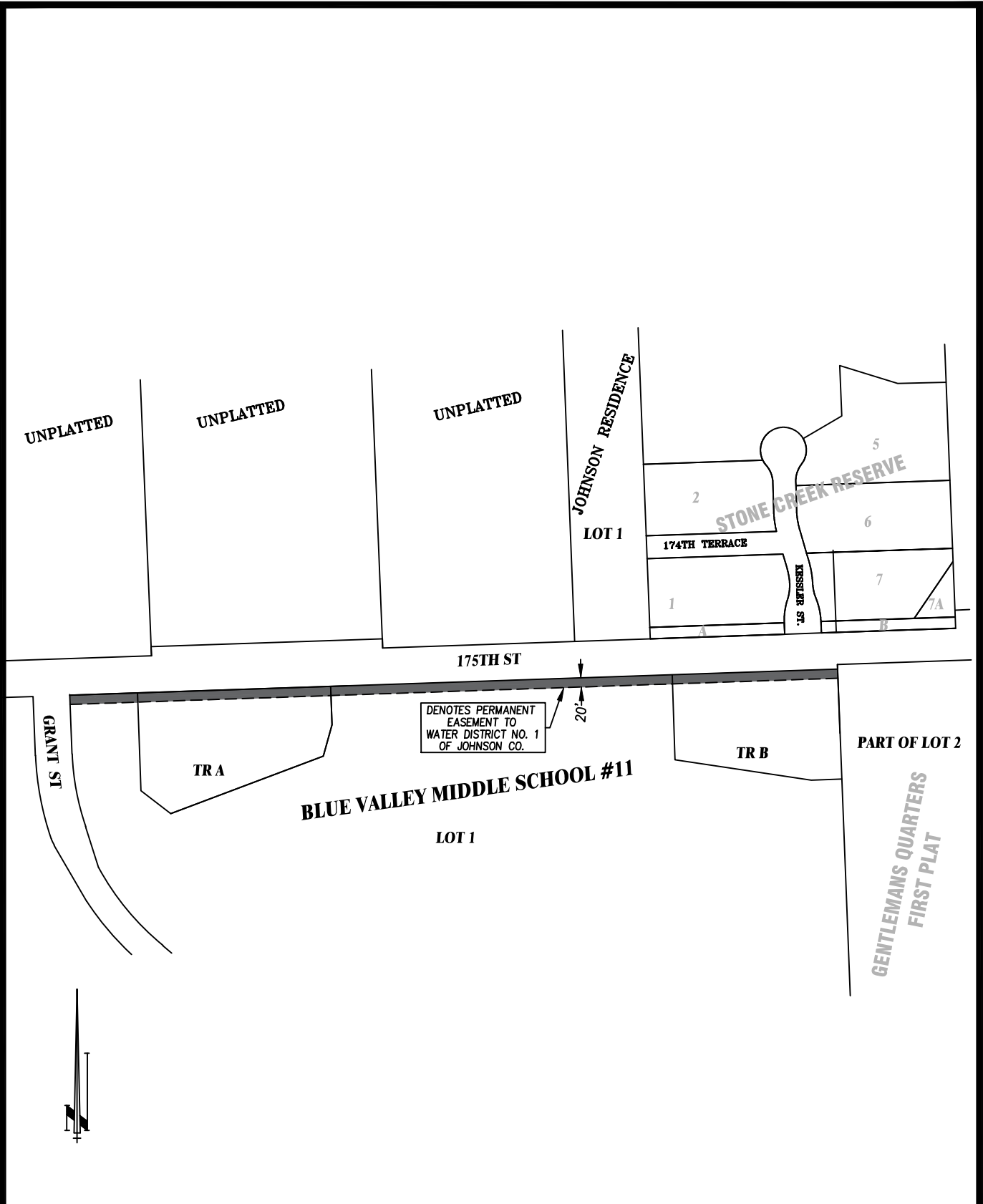

DENOTES PERMANENT EASEMENT TO WATER DISTRICT NO. 1 OF JOHNSON CO.



PLAT OF EASEMENT
BLUE VALLEY MIDDLE SCHOOL
NUMBER 11

DRAWN BY: <i>B.T.M.</i>	DATE: 7-16-25	SCALE: 1" = 300'	JOB NO. MX-25002
-------------------------	---------------	------------------	-------------------------



Human Resources Report to the Board of Education

Addendum

October 13, 2025

TERMINATION

<u>Name</u>	<u>Location</u>	<u>Position</u>	<u>Reason</u>
Hart, Barbara	SRE	Teacher	BOE Policy 3522 Violation



Human Resources Report to the Board of Education

Addendum

October 13, 2025

Administration recommends approval of the following actions:

RESIGNATIONS

<u>Name</u>	<u>Location</u>	<u>Position</u>	<u>Effective</u>
WIER, EUGENE PATRICK	BLUE VALLEY NORTH HIGH SCHOOL	TEACHER-PHYSICAL EDUCATION	12/31/2025



Human Resources Report to the Board of Education

Addendum

October 13, 2025

Administration recommends approval of the following actions:

SUPPLEMENTALS

<u>Name</u>	<u>Location</u>	<u>Position</u>	<u>Effective</u>
ADAIR, MARK JEFFREY	BLUE VALLEY MIDDLE SCHOOL	DIRECTOR-JAZZ BAND	08/06/2025
ADAIR, MARK JEFFREY	DISTRICT WIDE	LIMITED SUPPLY 3 OF 3	09/16/2025
ADAMS, SHANNON LEANN	BLUE VALLEY WEST HIGH SCHOOL	ADDL TEACHING PLAN-2ND SEM	01/05/2026
AGUILERA, ANDRES	BLUE VALLEY NORTH HIGH SCHOOL	ASST DIRECTOR-FALL PLAY	08/16/2025
AGUILERA, ANDRES	BLUE VALLEY NORTH HIGH SCHOOL	ASST DIRECTOR-WINTER MUSICAL	11/16/2025
ALDERMAN, GEORGE CURTIS	HARMONY MIDDLE SCHOOL	ASST COACH-BOYS BASKETBALL	11/16/2025
ALDERMAN, GEORGE CURTIS	HARMONY MIDDLE SCHOOL	ASST DIRECTOR-SPRING MUSICAL	11/16/2025
ALEXANDER, CARISSA N	OXFORD MIDDLE SCHOOL	SUPERVISOR-1/2 HR LUNCHROOM	08/06/2025
ALEXANDER, TARA MARIE	DISTRICT WIDE	LIMITED SUPPLY 2 OF 3	09/16/2025
ALLEN, BRIDGET ELAINE	BLUE VALLEY WEST HIGH SCHOOL	DEPARTMENT CHAIR-SPED	08/06/2025
ALLEN, CLAIRE A	DISTRICT WIDE	DRUG & ALCOHOL COORDINATOR	09/01/2025
ALLEN, CLAIRE A	LAKEWOOD MIDDLE SCHOOL	SUPERVISOR-1/2 HR LUNCHROOM	08/06/2025
ALLEN, LAUREN ELIZABETH	AUBRY BEND MIDDLE SCHOOL	SUPERVISOR-1/2 HR LUNCHROOM	08/06/2025
ALLPHIN, CIERRA LYNNE	BLUE VALLEY WEST HIGH SCHOOL	ASST COACH-TRACK	03/01/2026
ALLPHIN, RANSOM MCKAY	BLUE VALLEY WEST HIGH SCHOOL	ASST COACH-TRACK	03/01/2026
AMPADI RAMACHANDRAN, REMYA	LAKEWOOD MIDDLE SCHOOL	ASST SPONSOR-SCIENCE OLYMPIAD	09/23/2025
ANDERSON, CAROLINE KAY	DISTRICT WIDE	NATIONAL BOARD CERTIFICATION	08/06/2025
ANDERSON, JENNIFER KATHLEEN	DISTRICT WIDE	LIMITED SUPPLY 2 OF 3	09/16/2025
ANDREASEN, TRACEY LYNN	HARMONY MIDDLE SCHOOL	ASST DIRECTOR-SPRING MUSICAL	11/16/2025
ARBUCCI, LAUREN ASHLEY	BLUE VALLEY WEST HIGH SCHOOL	SUPERVISOR-LUNCHROOM	08/06/2025
ASHEN, JEFFREY S	BLUE VALLEY WEST HIGH SCHOOL	ADDL TEACHING PLAN-YEAR	08/06/2025
BABKIN, SARAH ELIZABETH	OXFORD MIDDLE SCHOOL	LEADERSHIP TEAM MEMBER	08/06/2025
BALINT, SARA A	BLUE VALLEY WEST HIGH SCHOOL	COORDINATOR-GRADE LEVEL	08/06/2025
BALL, JAMES ELVIN	HARMONY MIDDLE SCHOOL	ASST DIRECTOR-SPRING MUSICAL	11/16/2025
BALL, JULIE D	DISTRICT WIDE	DRUG & ALCOHOL COORDINATOR	09/01/2025
BALLEW, AARON JAMES	BLUE VALLEY SOUTHWEST HS	ADDL TEACHING PLAN-YEAR	08/06/2025
BANDRE, LISA	BLUE VALLEY WEST HIGH SCHOOL	ADDL TEACHING PLAN-YEAR	08/06/2025
BANE, LEAH MARY	DISTRICT WIDE	LIMITED SUPPLY 3 OF 3	09/16/2025
BANKS, ANGELA LAUREN	DISTRICT WIDE	LIMITED SUPPLY 3 OF 3	09/16/2025
BARILLEAUX, MARGARET ELIZABETH	DISTRICT WIDE	LIMITED SUPPLY 3 OF 3	09/16/2025
BARNES, DUSTIN LYNN	BLUE VALLEY SOUTHWEST HS	SUPERVISOR-LUNCHROOM	08/06/2025
BARNES, TARA MICHEL	DISTRICT WIDE	COORDINATOR-ART	08/06/2025
BARNHART, HEATHER ROSE	BLUE VALLEY WEST HIGH SCHOOL	DEPARTMENT CHAIR-ADVISORY	08/06/2025
BASOM, AMBER NICHOLE	DISTRICT WIDE	COORDINATOR-COUNSELING	08/06/2025
BASSHAM, CALEB	HARMONY MIDDLE SCHOOL	ASST DIRECTOR-SPRING MUSICAL	11/16/2025
BAUCOM, KELLI E	BLUE VALLEY SOUTHWEST HS	COORDINATOR-GRADE LEVEL	08/06/2025
BAUMAN, LISA ANN	DISTRICT WIDE	NATIONAL BOARD CERTIFICATION	08/06/2025
BAUMGART, LAUREN	DISTRICT WIDE	LIMITED SUPPLY 3 OF 3	09/16/2025
BAUS, KAREN ANN	DISTRICT WIDE	LIMITED SUPPLY 2 OF 3	09/16/2025
BELL, ELIZABETH JORDAN	DISTRICT WIDE	LIMITED SUPPLY 2 OF 3	09/16/2025



Human Resources Report to the Board of Education

Addendum

October 13, 2025

Administration recommends approval of the following actions:

BENSCHIEDT, LAURA LOUISE	CENTER FOR ADV PROF STUDIES	ADDL TEACHING RESPONSIBILITIES	08/06/2025
BENSCHIEDT, LAURA LOUISE	CENTER FOR ADV PROF STUDIES	CAPS BUSINESS PARTNERSHIP	08/06/2025
BENSCHIEDT, LAURA LOUISE	CENTER FOR ADV PROF STUDIES	CAPS STRAND LEADER	08/06/2025
BENSCHIEDT, LAURA LOUISE	DISTRICT WIDE	FACILITATOR-CURRICULUM TRAININ	08/06/2025
BENSCHIEDT, LAURA LOUISE	CENTER FOR ADV PROF STUDIES	HEAD SPONSOR-HOSA	08/06/2025
BERGEE, JILL A	DISTRICT WIDE	NATIONAL BOARD CERTIFICATION	08/06/2025
BERGERON, ALEC MICHEL	BLUE VALLEY WEST HIGH SCHOOL	ADDL TEACHING PLAN-YEAR	08/06/2025
BEYE, EMILY E	BLUE VALLEY MIDDLE SCHOOL	HEAD COACH-BOYS TRACK	03/01/2026
BIGELOW, ISABELLE MARIE	DISTRICT WIDE	LIMITED SUPPLY 3 OF 3	09/16/2025
BILLQUIST, LINDSAY ELIZABETH	LEAWOOD MIDDLE SCHOOL	SUPERVISOR-1/2 HR LUNCHROOM	08/06/2025
BIRNBAUM, CAROL ELLEN	DISTRICT WIDE	FACILITATOR-CURRICULUM TRAININ	08/06/2025
BISHOP, BRANDON E	BLUE VALLEY SOUTHWEST HS	ADDL TEACHING PLAN-YEAR	08/06/2025
BJORGO, LUKAS GENE	BLUE VALLEY SOUTHWEST HS	HEAD COACH-WRESTLING GIRLS	11/16/2025
BLACK, CARTER D	BLUE VALLEY WEST HIGH SCHOOL	ADDL TEACHING PLAN-YEAR	08/06/2025
BLACK, CARTER D	BLUE VALLEY WEST HIGH SCHOOL	COORDINATOR-GRADE LEVEL	08/06/2025
BLACK, CARTER D	DISTRICT WIDE	LIMITED SUPPLY 3 OF 3	09/16/2025
BLACKWELL, SHELLEY L	LEAWOOD ELEMENTARY	AD INTERN SUPERVISION DUTIES	08/06/2025
BOEHM, MEGHAN M	CENTER FOR ADV PROF STUDIES	ADDL TEACHING RESPONSIBILITIES	08/06/2025
BOEHM, MEGHAN M	CENTER FOR ADV PROF STUDIES	CAPS BUSINESS PARTNERSHIP	08/06/2025
BOGE, JULIA ANNE	CENTER FOR ADV PROF STUDIES	ADDL TEACHING RESPONSIBILITIES	08/06/2025
BOGE, JULIA ANNE	CENTER FOR ADV PROF STUDIES	CAPS BUSINESS PARTNERSHIP	08/06/2025
BOGE, JULIA ANNE	DISTRICT WIDE	FACILITATOR-CURRICULUM TRAININ	08/06/2025
BOLDRIDGE, CLAUDINE ELIZABETH	BLUE VALLEY NORTHWEST HS	8 EXTENDED DAYS-DEPT CHAIR	08/06/2025
BOLDRIDGE, CLAUDINE ELIZABETH	BLUE VALLEY NORTHWEST HS	DEPARTMENT CHAIR-SPED	08/06/2025
BOLLINGER, BRIAN ROBERT	HARMONY MIDDLE SCHOOL	SUPERVISOR-1/2 HR LUNCHROOM	08/06/2025
BOND, BENJAMIN KYLE	DISTRICT WIDE	COORDINATOR-PE	08/06/2025
BOOK, ANDREW JOHN	PLEASANT RIDGE MIDDLE SCHOOL	ADDL TEACHING RESPONSIBILITIES	08/06/2025
BOOS, MICHAEL TODD	BLUE VALLEY MIDDLE SCHOOL	ASST COACH-BOYS BASKETBALL	11/16/2025
BORCHER, MEGAN MICHELLE	DISTRICT WIDE	LIMITED SUPPLY 3 OF 3	09/16/2025
BORDONI, LILY SHAN	WOLF SPRINGS ELEMENTARY	ADDL TEACHING CI-YEAR	08/06/2025
BOX, BRIAN SAMUEL	BLUE VALLEY NORTH HIGH SCHOOL	DEPARTMENT CHAIR-PERFORM ARTS	08/06/2025
BRACHTENBACH, STEPHANIE NICOLE	DISTRICT WIDE	NATIONAL BOARD CERTIFICATION	08/06/2025
BREEDLOVE, JEFFREY MICHAEL	BLUE VALLEY NORTH HIGH SCHOOL	DEPARTMENT CHAIR-SOC SCIENCE	08/06/2025
BRIGGS, DAVID A	BLUE VALLEY HIGH SCHOOL	DEPARTMENT CHAIR-INDUST TECH	08/06/2025
BRIGGS, KEEGAN NICOLLE	DISTRICT WIDE	LIMITED SUPPLY 3 OF 3	09/16/2025
BRIODY, JILL M	DISTRICT WIDE	LIMITED SUPPLY 3 OF 3	09/16/2025
BRODERSEN, CHRISTOPHER GEORGE	OVERLAND TRAIL MIDDLE SCHOOL	ASST DIRECTOR-FALL MUSICAL	08/16/2025
BRODERSEN, CHRISTOPHER GEORGE	DISTRICT WIDE	FACILITATOR-CURRICULUM TRAININ	08/06/2025
BROWN, AMY JO	BLUE VALLEY WEST HIGH SCHOOL	DEPARTMENT CHAIR-COUNSELOR	08/06/2025
BROWN, PAUL B	BLUE VALLEY HIGH SCHOOL	DEPARTMENT CHAIR-PE	08/06/2025
BROWN, SARAH DOLENCE	BLUE VALLEY SOUTHWEST HS	DEPARTMENT CHAIR-MATH	08/06/2025
BRUCE, JUSTIN ALEXANDER	BLUE VALLEY MIDDLE SCHOOL	ASST COACH-BOYS BASKETBALL	11/16/2025
BRUCE, JUSTIN ALEXANDER	BLUE VALLEY MIDDLE SCHOOL	LEADERSHIP TEAM MEMBER	08/06/2025
BRUNER-LASISTER, HARMONY SAFFRON	DISTRICT WIDE	LIMITED SUPPLY 2 OF 3	09/16/2025



Human Resources Report to the Board of Education

Addendum

October 13, 2025

Administration recommends approval of the following actions:

BUCKNER, JEFFERY ALLEN	LAKESWOOD MIDDLE SCHOOL	SUPERVISOR-1/2 HR LUNCHROOM	08/06/2025
BUEHLER, GREGG ROWLAND	BLUE VALLEY SOUTHWEST HS	SUPERVISOR-LUNCHROOM	08/06/2025
BUEHLER, JENNIFER ALICIA	BLUE VALLEY WEST HIGH SCHOOL	DEPARTMENT CHAIR-SPED	08/06/2025
BURDICK, ANTHONY NAZIO	DISTRICT WIDE	FACILITATOR-CURRICULUM TRAININ	08/06/2025
BURGESS, TREVOR LEE	DISTRICT WIDE	DRUG & ALCOHOL COORDINATOR	09/01/2025
BUSHOUSE, KELLY ANNE	LAKESWOOD MIDDLE SCHOOL	ASST DIRECTOR-SPRING MUSICAL	03/01/2026
BUXTON, ASHLEY MARIE	DISTRICT WIDE	LIMITED SUPPLY 3 OF 3	09/16/2025
CAIN, RACHEL MAY	BLUE VALLEY NORTH HIGH SCHOOL	ASST DIRECTOR-WINTER MUSICAL	11/16/2025
CAIN, RACHEL MAY	BLUE VALLEY NORTH HIGH SCHOOL	DIRECTOR-WINTER MUSICAL	11/16/2025
CALLISON, KRISTIN GARNER	DISTRICT WIDE	COORDINATOR-PE	08/06/2025
CAMPBELL, ROBERT TODD	CENTER FOR ADV PROF STUDIES	ADDL TEACHING RESPONSIBILITIES	08/06/2025
CAMPBELL, ROBERT TODD	CENTER FOR ADV PROF STUDIES	CAPS BUSINESS PARTNERSHIP	08/06/2025
CARDOZO, SHERI ELISE	DISTRICT WIDE	LIMITED SUPPLY 3 OF 3	09/16/2025
CARENAS, SONIA MARIA	BLUE VALLEY NORTH HIGH SCHOOL	DEPARTMENT CHAIR-FOREIGN LNG	08/06/2025
CAREY, SOPHIA NICOLE	HARMONY MIDDLE SCHOOL	ASST DIRECTOR-SPRING MUSICAL	11/16/2025
CARPENTER, TERI RENEE	DISTRICT WIDE	LIMITED SUPPLY 3 OF 3	09/16/2025
CARR, ZACHARY BRENT	BLUE VALLEY NORTH HIGH SCHOOL	ASST COACH-BOYS BASKETBALL	11/16/2025
CARTER, EMILY ANNE	DISTRICT WIDE	LIMITED SUPPLY 3 OF 3	09/16/2025
CATANZARO, DANIEL M	BLUE VALLEY WEST HIGH SCHOOL	ADDL TEACHING PLAN-YEAR	08/06/2025
CATES, AMANDA GAYLE	DISTRICT WIDE	LIMITED SUPPLY 2 OF 3	09/16/2025
CHAUDHRY, HARRIS HAMEED	BLUE VALLEY SOUTHWEST HS	ASST COACH-DEBATE	10/01/2025
CHEN, RONALD CHING YUN	BLUE VALLEY NORTH HIGH SCHOOL	HEAD SPONSOR-SCIENCE OLYMPIAD	09/15/2025
CHENG, HSIAO CHING	WOLF SPRINGS ELEMENTARY	ADDL TEACHING CI-YEAR	08/06/2025
CHENG, YUAN	WOLF SPRINGS ELEMENTARY	ADDL TEACHING CI-YEAR	08/06/2025
CHEUNG, JENNY CHIEHNI	WOLF SPRINGS ELEMENTARY	ADDL TEACHING CI-YEAR	08/06/2025
CHRISTENSEN, MATTHEW CARY	BLUE VALLEY SOUTHWEST HS	DEPARTMENT CHAIR-SOC SCIENCE	08/06/2025
CHRISTENSEN, MATTHEW CARY	BLUE VALLEY SOUTHWEST HS	SUPERVISOR-LUNCHROOM	08/06/2025
CHRISTIANSEN, JULIE REBECCA	BLUE VALLEY MIDDLE SCHOOL	SUPERVISOR-1/2 HR LUNCHROOM	08/06/2025
CHUGG, JEREMY ALLAN	BLUE VALLEY NORTH HIGH SCHOOL	ADDL TEACHING PLAN-1ST SEM	08/06/2025
CHUSHUK, RACHEL SUZANNE	BLUE VALLEY SOUTHWEST HS	DEPARTMENT CHAIR-LIBRARY	08/06/2025
CLARK, KAITLYN N	OVERLAND TRAIL MIDDLE SCHOOL	ASST DIRECTOR-FALL MUSICAL	08/16/2025
CLARK, KAITLYN N	OVERLAND TRAIL MIDDLE SCHOOL	TEAM LEADER-OTHER RESP	08/06/2025
CLARK, KALI MAE	CENTER FOR ADV PROF STUDIES	SPONSOR-FIRST ROBOTICS	08/16/2025
CLAUSEN, MELODY J	BLUE VALLEY SOUTHWEST HS	DEPARTMENT CHAIR-SCIENCE	08/06/2025
COBLE, EMMA LOUISE	DISTRICT WIDE	LIMITED SUPPLY 2 OF 3	09/16/2025
COCHERL, ANNA MARIE	HARMONY MIDDLE SCHOOL	ASST DIRECTOR-SPRING MUSICAL	11/16/2025
COCUMELLI, BRITT P	DISTRICT WIDE	LIMITED SUPPLY 3 OF 3	09/16/2025
COLLINS, CAMERON SLADE	OXFORD MIDDLE SCHOOL	SPONSOR-STUDENT COUNCIL	08/06/2025
COLLINS, CAMERON SLADE	OXFORD MIDDLE SCHOOL	SUPERVISOR-1/2 HR LUNCHROOM	08/06/2025
COLLINS, TIMOTHY HOWARD	BLUE VALLEY NORTHWEST HS	SPONSOR-NATL CURRIC HONOR SOC	08/06/2025
CONLEY, KYLE BOYD	BLUE VALLEY WEST HIGH SCHOOL	ADDL TEACHING SUPV-YEAR	08/06/2025
CONRAD, LAUREL MARIE	DISTRICT WIDE	BCBA CERTIFICATION	08/06/2025
CONSTANCE, LISA M	DISTRICT WIDE	LIMITED SUPPLY 3 OF 3	09/16/2025
COOK, BRADLEY ALAN	AUBRY BEND MIDDLE SCHOOL	SUPERVISOR-1/2 HR LUNCHROOM	08/06/2025



Human Resources Report to the Board of Education

Addendum

October 13, 2025

Administration recommends approval of the following actions:

COOK, LORI MARIE	HARMONY MIDDLE SCHOOL	LEADERSHIP TEAM MEMBER	08/06/2025
COOK, RACHEL ELIZABETH	BLUE VALLEY SOUTHWEST HS	ADDL TEACHING SUPV-YEAR	08/06/2025
COOK, RACHEL ELIZABETH	BLUE VALLEY SOUTHWEST HS	SUPERVISOR-LUNCHROOM	08/06/2025
COOPER, LINDA L	BLUE VALLEY MIDDLE SCHOOL	ASST COACH-GIRLS BASKETBALL	11/16/2025
COPELAND, ELIZABETH NASH	LEAWOOD MIDDLE SCHOOL	ADDL TEACHING RESPONSIBILITIES	08/06/2025
CORDELL, MICHAEL DAVID	LEAWOOD MIDDLE SCHOOL	SUPERVISOR-1/2 HR LUNCHROOM	08/06/2025
CORDES, SHANNON LEE ANDREW	BLUE VALLEY NORTH HIGH SCHOOL	ASST COACH-BOYS BASKETBALL	11/16/2025
CORNELIUS, ABIGAIL M	BLUE VALLEY NORTH HIGH SCHOOL	COORDINATOR-BUILDING ADVISORY	08/06/2025
CORNELIUS, ABIGAIL M	BLUE VALLEY NORTH HIGH SCHOOL	DEPARTMENT CHAIR-LIBRARY	08/06/2025
CORNELIUS, ABIGAIL M	DISTRICT WIDE	NATIONAL BOARD CERTIFICATION	08/06/2025
CRANE, ALISON DALE	CENTER FOR ADV PROF STUDIES	ADDL TEACHING RESPONSIBILITIES	08/06/2025
CRANE, ALISON DALE	CENTER FOR ADV PROF STUDIES	CAPS BUSINESS PARTNERSHIP	08/06/2025
CRANE, ALISON DALE	DISTRICT WIDE	COORDINATOR-ART	08/06/2025
CRANE, ALISON DALE	DISTRICT WIDE	FACILITATOR-CURRICULUM TRAININ	08/06/2025
CRAVEN, KAITLYN MARIE	DISTRICT WIDE	LIMITED SUPPLY 3 OF 3	09/16/2025
DAIGLE, JOHN PAUL	BLUE VALLEY NORTH HIGH SCHOOL	DEPARTMENT CHAIR-SPED	08/06/2025
DALTON, REBECCA A	BLUE VALLEY NORTH HIGH SCHOOL	COORDINATOR-GRADE LEVEL	08/06/2025
DALTON, REBECCA A	DISTRICT WIDE	NATIONAL BOARD CERTIFICATION	08/06/2025
DARK, ANN C	BLUE VALLEY WEST HIGH SCHOOL	ADDL TEACHING PLAN-YEAR	08/06/2025
DARK, ANN C	BLUE VALLEY WEST HIGH SCHOOL	DEPARTMENT CHAIR-CTE	08/06/2025
DAVIDSON, MARGARET SUE	BLUE VALLEY SOUTHWEST HS	ADDL TEACHING SUPV-YEAR	08/06/2025
DAVILA TORRES, SOFIA D	DISTRICT WIDE	LIMITED SUPPLY 3 OF 3	09/16/2025
DAVIS, DAVID L	HARMONY MIDDLE SCHOOL	ASST COACH-TRACK	03/01/2026
DE LEIRIS, JULIEN PIERRE HERVE	OVERLAND TRAIL MIDDLE SCHOOL	ASST SPONSOR-SCIENCE OLYMPIAD	09/11/2025
DEFFER, LAURA ANN	BLUE VALLEY NORTHWEST HS	12 EXTENDED DAYS-DEPT CHAIR	08/06/2025
DEFFER, LAURA ANN	BLUE VALLEY NORTHWEST HS	DEPARTMENT CHAIR-MATH	08/06/2025
DEFFER, NICHOLAS ANTHONY	BLUE VALLEY HIGH SCHOOL	ADDL TEACHING PLAN-YEAR	08/06/2025
DELGROSSO, ABIGAIL ROSE	BLUE VALLEY MIDDLE SCHOOL	SUPERVISOR-1/2 HR LUNCHROOM	08/06/2025
DICKERSON, STACEY E	PLEASANT RIDGE MIDDLE SCHOOL	SUPERVISOR-1/2 HR LUNCHROOM	08/06/2025
DICKERSON, TYLER JOHN	BLUE VALLEY WEST HIGH SCHOOL	ADDL TEACHING PLAN-1ST SEM	08/06/2025
DICKINSON, JAYMES EDWARD	BLUE VALLEY SOUTHWEST HS	SUPERVISOR-LUNCHROOM	08/06/2025
DILLON, JORDAN ZACHARY	BLUE VALLEY HIGH SCHOOL	ADDL TEACHING SUPV-YEAR	08/06/2025
DINSMORE, JACKSON RILEY	BLUE VALLEY NORTH HIGH SCHOOL	COORDINATOR-GRADE LEVEL	08/06/2025
DIXON, KRISTI L	DISTRICT WIDE	COORDINATOR-COUNSELING	08/06/2025
DIXON, KRISTI L	DISTRICT WIDE	DRUG & ALCOHOL COORDINATOR	09/01/2025
DOCKENDORF, SARAH ANN	BLUE VALLEY NORTH HIGH SCHOOL	SUPERVISOR-LUNCHROOM	08/06/2025
DOWNEY, BRITTANY LYNN	AUBRY BEND MIDDLE SCHOOL	ASST DIRECTOR-FALL MUSICAL	08/16/2025
DOWNEY, BRITTANY LYNN	DISTRICT WIDE	LIMITED SUPPLY 3 OF 3	09/16/2025
DREW, MOLLY MARGARET	DISTRICT WIDE	LIMITED SUPPLY 3 OF 3	09/16/2025
DREYER, MIKAYLA WEBER	DISTRICT WIDE	BCBA CERTIFICATION	08/06/2025
DUGAN, JENNIFER GILL	DISTRICT WIDE	NATIONAL BOARD CERTIFICATION	08/06/2025
DUGAN, JENNIFER GILL	OXFORD MIDDLE SCHOOL	SPONSOR-NEWSPAPER	08/06/2025
DUGAN, JENNIFER GILL	OXFORD MIDDLE SCHOOL	SPONSOR-STUDENT COUNCIL	08/06/2025
DUGAN, JENNIFER GILL	OXFORD MIDDLE SCHOOL	SUPERVISOR-1/2 HR LUNCHROOM	08/06/2025



Human Resources Report to the Board of Education

Addendum

October 13, 2025

Administration recommends approval of the following actions:

DUGAN, MOLLY MARIE	DISTRICT WIDE	LIMITED SUPPLY 2 OF 3	09/16/2025
DUGGAN, JENNIFER ANNE	DISTRICT WIDE	NATIONAL BOARD CERTIFICATION	08/06/2025
DUMMITT, ANNE MARIE	LAKESWOOD MIDDLE SCHOOL	SUPERVISOR-1/2 HR LUNCHROOM	08/06/2025
DUNN, ANNA LEIGH	BLUE VALLEY WEST HIGH SCHOOL	COORDINATOR-GRADE LEVEL	08/06/2025
DUNN, ANNA LEIGH	BLUE VALLEY WEST HIGH SCHOOL	DEPARTMENT CHAIR-FOREIGN LNG	08/06/2025
DURDYEVA, MAHRI	DISTRICT WIDE	LIMITED SUPPLY 3 OF 3	09/16/2025
ECKROAT, JENNIFER MICHELLE	DISTRICT WIDE	NATIONAL BOARD CERTIFICATION	08/06/2025
EHRET, BENJAMIN JAMES	BLUE VALLEY WEST HIGH SCHOOL	ADDL TEACHING PLAN-YEAR	08/06/2025
EHRET, BENJAMIN JAMES	DISTRICT WIDE	LIMITED SUPPLY 3 OF 3	09/16/2025
ELGIN, DEANNA PAIGE	BLUE VALLEY NORTHWEST HS	COORDINATOR-GRADE LEVEL	08/06/2025
ENGEL, CASEY KATHLEEN	BLUE VALLEY HIGH SCHOOL	DEPARTMENT CHAIR-COMM ARTS	08/06/2025
ERBACHER, STEVEN ELVIS	BLUE VALLEY HIGH SCHOOL	ASST COACH-BOYS BASKETBALL	11/16/2025
ERNST, LIZABETH LEON	BLUE VALLEY HIGH SCHOOL	ASST DIRECTOR-FALL MUSICAL	10/02/2025
ERPELDING, JUDY ELLEN	DISTRICT WIDE	LIMITED SUPPLY 3 OF 3	09/16/2025
ESPITIA, SANDY DIANA	BLUE VALLEY WEST HIGH SCHOOL	ADDL TEACHING PLAN-YEAR	08/06/2025
ESPITIA, SANDY DIANA	DISTRICT WIDE	NATIONAL BOARD CERTIFICATION	08/06/2025
ESSEX, STEPHEN	PRAIRIE STAR MIDDLE SCHOOL	ASST COACH-BOYS BASKETBALL	11/16/2025
ESSEX, STEPHEN	PRAIRIE STAR MIDDLE SCHOOL	SUPERVISOR-1/2 HR LUNCHROOM	08/06/2025
FELKE BOWDEN, CAREY ANNE	CEDAR HILLS ELEMENTARY	DIRECTOR-CHOIR	08/06/2025
FERGUSON, ASHLEY STEELE	DISTRICT WIDE	LIMITED SUPPLY 3 OF 3	09/16/2025
FERNANDEZ, VANESSA MARIA	OVERLAND TRAIL MIDDLE SCHOOL	SUPERVISOR-1/2 HR LUNCHROOM	08/06/2025
FINE, ERIN PATRICIA	BLUE VALLEY SOUTHWEST HS	COORDINATOR-BUILDING ADVISORY	08/06/2025
FISCHER, KATHERINE MIKAYLA	LAKESWOOD MIDDLE SCHOOL	ASST DIRECTOR-SPRING MUSICAL	11/16/2025
FISHER, TESSA LYNN	BLUE VALLEY NORTHWEST HS	COORDINATOR-GRADE LEVEL	08/06/2025
FLEMING, JULIA R	DISTRICT WIDE	LIMITED SUPPLY 3 OF 3	09/16/2025
FOLLOWELL, LISA MARIE	OXFORD MIDDLE SCHOOL	SUPERVISOR-1/2 HR LUNCHROOM	08/06/2025
FOOTE, JORDAN RICHARD	BLUE VALLEY SOUTHWEST HS	6 EXTENDED DAYS-DEPT CHAIR	08/06/2025
FOOTE, JORDAN RICHARD	BLUE VALLEY SOUTHWEST HS	DEPARTMENT CHAIR-PERFORM ARTS	08/06/2025
FORNELLI, RYLIE MICHELE	BLUE VALLEY SOUTHWEST HS	DEPARTMENT CHAIR-SPED	08/06/2025
FORNELLI, RYLIE MICHELE	DISTRICT WIDE	LIMITED SUPPLY 3 OF 3	09/16/2025
FRANEY, LYNN GABRIELLE	DISTRICT WIDE	NATIONAL BOARD CERTIFICATION	08/06/2025
FRANKLIN, HARRISON DAVID	LAKESWOOD MIDDLE SCHOOL	ASST DIRECTOR-FALL PLAY	08/16/2025
FRIEDEBACH, WILLIAM G	DISTRICT WIDE	LIMITED SUPPLY 3 OF 3	09/16/2025
FRITZ, ANN M	BLUE VALLEY NORTH HIGH SCHOOL	DEPARTMENT CHAIR-PE	08/06/2025
FROMME, KYMBERLY LYNNE	OXFORD MIDDLE SCHOOL	ASST DIRECTOR-FALL PLAY	08/16/2025
FROMME, KYMBERLY LYNNE	OXFORD MIDDLE SCHOOL	ASST DIRECTOR-SPRING MUSICAL	11/16/2025
FROMME, KYMBERLY LYNNE	OXFORD MIDDLE SCHOOL	LEADERSHIP TEAM MEMBER	08/06/2025
FROST, HOLLY JOELLE	DISTRICT WIDE	LIMITED SUPPLY 3 OF 3	09/16/2025
GALL, MOLLY MAHER	DISTRICT WIDE	LIMITED SUPPLY 2 OF 3	09/16/2025
GALLEGOS, JAMEY L	DISTRICT WIDE	LIMITED SUPPLY 2 OF 3	09/16/2025
GARCIA, KYLIE RENEE	BLUE VALLEY HIGH SCHOOL	DEPARTMENT CHAIR-FOREIGN LNG	08/06/2025
GARCIA, MARIA INES	HARMONY MIDDLE SCHOOL	ASST COACH-TRACK	03/01/2026
GASSMAN, OLIVIA M	DISTRICT WIDE	LIMITED SUPPLY 3 OF 3	09/16/2025
GAY, SUZANNE LORENE	DISTRICT WIDE	LEADERSHIP STIPEND-OT	08/06/2025



Human Resources Report to the Board of Education

Addendum

October 13, 2025

Administration recommends approval of the following actions:

GAY, SUZANNE LORENE	EDUCATIONAL SUPPORT CENTER	MENTOR-NEW TO BV OT	08/06/2025
GERFEN, CHRISTI LEA	DISTRICT WIDE	LIMITED SUPPLY 2 OF 3	09/16/2025
GERFEN, CRAIG W	DISTRICT WIDE	LIMITED SUPPLY 2 OF 3	09/16/2025
GESSLEY, JENNIFER ANN	DISTRICT WIDE	NATIONAL BOARD CERTIFICATION	08/06/2025
GEYER, AMANDA MAE	DISTRICT WIDE	LIMITED SUPPLY 3 OF 3	09/16/2025
GIULIANI, GABRIELLA N	DISTRICT WIDE	LIMITED SUPPLY 3 OF 3	09/16/2025
GO, MELISSIA MARIE	BLUE VALLEY SOUTHWEST HS	SUPERVISOR-LUNCHROOM	08/06/2025
GOLDEN, VALERIE VRANA	BLUE VALLEY NORTHWEST HS	12 EXTENDED DAYS-DEPT CHAIR	08/06/2025
GOLDEN, VALERIE VRANA	BLUE VALLEY NORTHWEST HS	DEPARTMENT CHAIR-COMM ARTS	08/06/2025
GOLDEN, VALERIE VRANA	DISTRICT WIDE	NATIONAL BOARD CERTIFICATION	08/06/2025
GOODEN, AUSTIN EDWARD	AUBRY BEND MIDDLE SCHOOL	SUPERVISOR-1/2 HR LUNCHROOM	08/06/2025
GOODWIN, STEPHANIE LYNN	DISTRICT WIDE	LIMITED SUPPLY 3 OF 3	09/16/2025
GORMLEY, ALEXIS NICOLE	DISTRICT WIDE	LEADERSHIP STIPEND-PSYCH	08/06/2025
GOUGER, JILL MARIE	OXFORD MIDDLE SCHOOL	CRD-STUDENT & COMM ENGAGEMENT	08/06/2025
GRAHAM, JANET LYNN	CENTER FOR ADV PROF STUDIES	ADDL TEACHING RESPONSIBILITIES	08/06/2025
GRAHAM, JANET LYNN	CENTER FOR ADV PROF STUDIES	CAPS BUSINESS PARTNERSHIP	08/06/2025
GRAHAM, JANET LYNN	CENTER FOR ADV PROF STUDIES	HEAD SPONSOR-DECA/FBLA/BPA	08/06/2025
GREEN, JENNIFER KATHERINE	BLUE VALLEY MIDDLE SCHOOL	LEADERSHIP TEAM MEMBER	08/06/2025
GREER, ANGELA JOY	DISTRICT WIDE	LIMITED SUPPLY 3 OF 3	09/16/2025
GRIMALDI, COURTNEY DANIELLE	BLUE VALLEY WEST HIGH SCHOOL	DEPARTMENT CHAIR-ADVISORY	08/06/2025
GRIMALDI, COURTNEY DANIELLE	BLUE VALLEY WEST HIGH SCHOOL	DEPARTMENT CHAIR-LIBRARY	08/06/2025
GRIMSLEY, HEATHER A	AUBRY BEND MIDDLE SCHOOL	LEADERSHIP TEAM MEMBER	08/06/2025
GRINDSTAFF, ADAM H	DISTRICT WIDE	FACILITATOR-CURRICULUM TRAININ	08/06/2025
GRINDSTAFF, ADAM H	LAKWOOD MIDDLE SCHOOL	LEADERSHIP TEAM MEMBER	08/06/2025
GRINDSTAFF, ADAM H	LAKWOOD MIDDLE SCHOOL	SUPERVISOR-1/2 HR LUNCHROOM	08/06/2025
GROSPITCH, THERESA LYNN	BLUE VALLEY WEST HIGH SCHOOL	ADDL TEACHING PLAN-YEAR	08/06/2025
GROSPITCH, THERESA LYNN	BLUE VALLEY WEST HIGH SCHOOL	DEPARTMENT CHAIR-MATH	08/06/2025
GROSPITCH, THERESA LYNN	DISTRICT WIDE	NATIONAL BOARD CERTIFICATION	08/06/2025
GRUSENMEYER, MOLLY ANNE	DISTRICT WIDE	FACILITATOR-CURRICULUM TRAININ	08/06/2025
GRUSENMEYER, MOLLY ANNE	PLEASANT RIDGE MIDDLE SCHOOL	SPONSOR-STUDENT COUNCIL	08/06/2025
GUDENKAUF, AMY SUSAN	OXFORD MIDDLE SCHOOL	ASST DIRECTOR-FALL PLAY	08/16/2025
GUTHRIE, ERIN D	BLUE VALLEY NORTH HIGH SCHOOL	ADDL TEACHING SUPV-YEAR	08/06/2025
GUTHRIE, ERIN D	BLUE VALLEY NORTH HIGH SCHOOL	DEPARTMENT CHAIR-FACS	08/06/2025
GUTIERREZ, CONNY DANIELA	BLUE VALLEY NORTHWEST HS	COORDINATOR-GRADE LEVEL	08/06/2025
GUTIERREZ, CONNY DANIELA	DISTRICT WIDE	LIMITED SUPPLY 2 OF 3	09/16/2025
HAGAN, CHRISTY S	DISTRICT WIDE	NATIONAL BOARD CERTIFICATION	08/06/2025
HAGAN, MICHAEL JOSEPH	DISTRICT WIDE	LIMITED SUPPLY 3 OF 3	09/16/2025
HAGGERTY, MOLLY ANN	BLUE VALLEY NORTHWEST HS	ADDL TEACHING PLAN-2ND SEM	01/05/2026
HAGSTROM, HEATHER MARIE	DISTRICT WIDE	NATIONAL BOARD CERTIFICATION	08/06/2025
HALEY, JOHN ISAAC	VIRTUAL ED	VIRTUAL EDUCATION-FALL	08/06/2025
HALL, HEATHER ELIZABETH	BLUE VALLEY WEST HIGH SCHOOL	ADDL TEACHING PLAN-YEAR	08/06/2025
HALL, HEATHER ELIZABETH	BLUE VALLEY WEST HIGH SCHOOL	DEPARTMENT CHAIR-SCIENCE	08/06/2025
HALL, SANDRA BIDDLE	LEAWOOD MIDDLE SCHOOL	ASST SPONSOR-SCIENCE OLYMPIAD	09/22/2025
HAMERA, AMY REBECCA	CENTER FOR ADV PROF STUDIES	ADDL TEACHING RESPONSIBILITIES	08/06/2025



Human Resources Report to the Board of Education

Addendum

October 13, 2025

Administration recommends approval of the following actions:

HAMERA, AMY REBECCA	CENTER FOR ADV PROF STUDIES	CAPS BUSINESS PARTNERSHIP	08/06/2025
HANTLA, GABRIELLA JOY	OVERLAND TRAIL MIDDLE SCHOOL	HEAD COACH-WRESTLING BOYS	11/16/2025
HANTLA, GABRIELLA JOY	OVERLAND TRAIL MIDDLE SCHOOL	HEAD COACH-WRESTLING GIRLS	11/16/2025
HARVEY, ANNE MARIE	DISTRICT WIDE	DIST CRD-STUDENT & COMM ENGMNT	08/06/2025
HASSELBRING, KELSEY LOUISE	BLUE VALLEY MIDDLE SCHOOL	HEAD COACH-GIRLS TRACK	03/01/2026
HASSELBRING, KELSEY LOUISE	BLUE VALLEY MIDDLE SCHOOL	SUPERVISOR-1/2 HR LUNCHROOM	08/06/2025
HASSELBRING, KELSEY LOUISE	VIRTUAL ED	VIRTUAL EDUCATION-FALL	08/06/2025
HEALY, REBECCA ANN	DISTRICT WIDE	LEADERSHIP STIPEND-SLP	08/06/2025
HEARNS, MARY DEIRDRE	DISTRICT WIDE	LIMITED SUPPLY 2 OF 3	09/16/2025
HEDLUND, TRENTON J	BLUE VALLEY NORTH HIGH SCHOOL	SUPERVISOR-GYMNASIUM	11/16/2025
HEERE, ALLISON KIRBY	OAK HILL ELEMENTARY	16 EXTENDED DAYS-IDC	08/06/2025
HEERE, ALLISON KIRBY	CEDAR HILLS ELEMENTARY	16 EXTENDED DAYS-IDC	08/06/2025
HEIDESCH, SARAH ELIZABETH	DISTRICT WIDE	LIMITED SUPPLY 2 OF 3	10/01/2025
HELLWIG, MATTIE B	DISTRICT WIDE	LIMITED SUPPLY 3 OF 3	09/16/2025
HENDERSON, KAREN MS	BLUE VALLEY NORTHWEST HS	ADDL TEACHING PLAN-YEAR	08/06/2025
HENDERSON, KAREN MS	DISTRICT WIDE	FACILITATOR-CURRICULUM TRAININ	08/06/2025
HENDERSON, KAREN MS	DISTRICT WIDE	NATIONAL BOARD CERTIFICATION	08/06/2025
HILLEN, KARI ANN	BLUE VALLEY NORTHWEST HS	8 EXTENDED DAYS-DEPT CHAIR	08/06/2025
HIRONS, ALISON ELIZABETH	DISTRICT WIDE	LIMITED SUPPLY 3 OF 3	09/16/2025
HOCHLER, JULIE ANN	DISTRICT WIDE	LIMITED SUPPLY 3 OF 3	09/16/2025
HOEVEN, MARIE ANN	BLUE VALLEY WEST HIGH SCHOOL	ADDL TEACHING PLAN-YEAR	08/06/2025
HOGAN, NICOLE K	DISTRICT WIDE	LIMITED SUPPLY 2 OF 3	09/16/2025
HOGLUND, KIMBERLY JO	DISTRICT WIDE	LIMITED SUPPLY 2 OF 3	09/16/2025
HOGLUND, KIMBERLY JO	DISTRICT WIDE	NATIONAL BOARD CERTIFICATION	08/06/2025
HOING, JENNA MARIE	BLUE VALLEY NORTHWEST HS	8 EXTENDED DAYS-DEPT CHAIR	08/06/2025
HOING, JENNA MARIE	BLUE VALLEY NORTHWEST HS	DEPARTMENT CHAIR-SPED	08/06/2025
HOIT, LYNDI LEE	DISTRICT WIDE	LIMITED SUPPLY 3 OF 3	09/16/2025
HOLEHAN, TRAVIS PATRICK	BLUE VALLEY WEST HIGH SCHOOL	ADDL TEACHING PLAN-YEAR	08/06/2025
HOLKER, HOLLY ANNE	DISTRICT WIDE	LIMITED SUPPLY 2 OF 3	09/16/2025
HOLLAND, TOM E	BLUE VALLEY NORTH HIGH SCHOOL	DEPARTMENT CHAIR-ART	08/06/2025
HOLLIS, BLAIR CAITLIN	HARMONY MIDDLE SCHOOL	ASST COACH-TRACK	03/01/2026
HOLLIS, BLAIR CAITLIN	HARMONY MIDDLE SCHOOL	SUPERVISOR-1/2 HR LUNCHROOM	08/06/2025
HOLSAPPLE, MEGAN KRISTINA	LAKESWOOD MIDDLE SCHOOL	SUPERVISOR-1/2 HR LUNCHROOM	08/06/2025
HOLTHAUS, AARON FRANCIS	CENTER FOR ADV PROF STUDIES	ADDL TEACHING RESPONSIBILITIES	08/06/2025
HOLTHAUS, AARON FRANCIS	CENTER FOR ADV PROF STUDIES	CAPS BUSINESS PARTNERSHIP	08/06/2025
HOLUB, HILLARY ANNE	DISTRICT WIDE	LIMITED SUPPLY 2 OF 3	09/16/2025
HONNOLD, RACHAEL A	OVERLAND TRAIL MIDDLE SCHOOL	ASST DIRECTOR-FALL MUSICAL	08/16/2025
HORA, CAMERON MICHAEL	DISTRICT WIDE	LIMITED SUPPLY 3 OF 3	09/16/2025
HORSTICK, JESSICA ELIZABETH	BLUE VALLEY WEST HIGH SCHOOL	ADDL TEACHING PLAN-YEAR	08/06/2025
HOUSTON, TIMOTHY MICHAEL	HARMONY MIDDLE SCHOOL	ASST DIRECTOR-SPRING MUSICAL	11/16/2025
HOWARD, DEREK LEE	BLUE VALLEY WEST HIGH SCHOOL	DEPARTMENT CHAIR-PE	08/06/2025
HOWARD, GARY LEON	BLUE VALLEY NORTHWEST HS	ADMIN CONSULTATNT SUPV STIP	08/06/2025
HOYLE, KAITLIN KAE	DISTRICT WIDE	LIMITED SUPPLY 1 OF 3	09/16/2025
HUDNALL, SYDNEY MARIE	DISTRICT WIDE	LIMITED SUPPLY 3 OF 3	09/16/2025



Human Resources Report to the Board of Education

Addendum

October 13, 2025

Administration recommends approval of the following actions:

HULL, COURTNEY ANN	DISTRICT WIDE	LIMITED SUPPLY 2 OF 3	09/16/2025
HUNT, ELYSE E	DISTRICT WIDE	LIMITED SUPPLY 3 OF 3	09/16/2025
HUO, QIUJU	BLUE VALLEY NORTH HIGH SCHOOL	ADDL TEACHING PLAN-YEAR	08/06/2025
HURLBUT, ERICA LAIRD	HARMONY MIDDLE SCHOOL	LEADERSHIP TEAM MEMBER	08/06/2025
HURST, KIMBERLY AUSTIN	BLUE VALLEY MIDDLE SCHOOL	LEADERSHIP TEAM MEMBER	08/06/2025
HUSS, MICHELLE NICOLE	DISTRICT WIDE	FACILITATOR-CURRICULUM TRAININ	08/06/2025
ISELL, TRISTAN PATRICK	OXFORD MIDDLE SCHOOL	SUPERVISOR-1/2 HR LUNCHROOM	08/06/2025
ISELL, TRISTAN PATRICK	VIRTUAL ED	VIRTUAL EDUCATION-FALL	08/06/2025
JACKSON, LISA INEZ	OVERLAND TRAIL MIDDLE SCHOOL	HEAD COACH-BOYS TRACK	03/01/2026
JACOBS, JESSICA RENEE	DISTRICT WIDE	LIMITED SUPPLY 3 OF 3	09/16/2025
JAMES, BRITTANIE RENEE	DISTRICT WIDE	LIMITED SUPPLY 3 OF 3	09/16/2025
JENSEN, JAMES HENRY	BLUE VALLEY MIDDLE SCHOOL	ASST COACH-FOOTBALL	08/16/2025
JIN, SOOJIN CLARA	SUNSET RIDGE ELEMENTARY	DIRECTOR-CHOIR	09/19/2025
JOHNSTON, MICHAEL A	BLUE VALLEY HIGH SCHOOL	DEPARTMENT CHAIR-ART	08/06/2025
JONES, CROSBY ANN	OVERLAND TRAIL MIDDLE SCHOOL	SUPERVISOR-1/2 HR LUNCHROOM	08/06/2025
JURKOVAC, JESSICA E	AUBRY BEND MIDDLE SCHOOL	ASST COACH-CROSS COUNTRY	08/16/2025
KANAN, WILLIAM HENRY	LEAWOOD MIDDLE SCHOOL	SUPERVISOR-1/2 HR LUNCHROOM	08/06/2025
KANAREK, ELI S	BLUE VALLEY HIGH SCHOOL	DEPARTMENT CHAIR-SPED	08/06/2025
KARR, BROOKE D	DISTRICT WIDE	LIMITED SUPPLY 3 OF 3	09/16/2025
KAUR, PAWANDEEP	DISTRICT WIDE	LIMITED SUPPLY 1 OF 3	09/16/2025
KELLER, MEGAN LEIGH	DISTRICT WIDE	LIMITED SUPPLY 2 OF 3	09/16/2025
KELLER, STEPHANIE SUSAN	DISTRICT WIDE	DRUG & ALCOHOL COORDINATOR	09/01/2025
KENNEY, KATIE MARCELA	DISTRICT WIDE	LIMITED SUPPLY 2 OF 3	09/16/2025
KESSLER, ERIC M	CENTER FOR ADV PROF STUDIES	ADDL TEACHING RESPONSIBILITIES	08/06/2025
KESSLER, ERIC M	CENTER FOR ADV PROF STUDIES	CAPS BUSINESS PARTNERSHIP	08/06/2025
KESSLER, ERIC M	CENTER FOR ADV PROF STUDIES	CAPS STRAND LEADER	08/06/2025
KESSLER, ERIC M	DISTRICT WIDE	NATIONAL BOARD CERTIFICATION	08/06/2025
KINKELAAR, KERRY MAE	DISTRICT WIDE	NATIONAL BOARD CERTIFICATION	08/06/2025
KIRK, DELANEY LOGAN	LIBERTY VIEW ELEMENTARY	DIRECTOR-CHOIR	08/06/2025
KISSANE, KEVIN PATRICK	BLUE VALLEY WEST HIGH SCHOOL	ASST COACH-WRESTLING BOYS	11/16/2025
KNEIB, KADI L	DISTRICT WIDE	LIMITED SUPPLY 3 OF 3	09/16/2025
KOCH, BARRET LUCAS	AUBRY BEND MIDDLE SCHOOL	ADDL TEACHING PLAN-1ST SEM	08/06/2025
KOCH, BARRET LUCAS	LEAWOOD MIDDLE SCHOOL	ADDL TEACHING RESPONSIBILITIES	08/06/2025
KOCH, BARRET LUCAS	AUBRY BEND MIDDLE SCHOOL	LEADERSHIP TEAM MEMBER	08/06/2025
KOZLOWSKI, ERIN NICOLE	DISTRICT WIDE	LIMITED SUPPLY 3 OF 3	09/16/2025
KREHBIEL, LINDSAY RENEE	BLUE VALLEY WEST HIGH SCHOOL	ADDL TEACHING PLAN-2ND SEM	01/05/2026
KREHBIEL, LINDSAY RENEE	VIRTUAL ED	VIRTUAL EDUCATION-FALL	08/06/2025
KREWSON, SICILEY P	BLUE VALLEY SOUTHWEST HS	ADDL TEACHING PLAN-2ND SEM	01/05/2026
KREWSON, SICILEY P	BLUE VALLEY SOUTHWEST HS	DEPARTMENT CHAIR-CTE	08/06/2025
KREWSON, SICILEY P	DISTRICT WIDE	FACILITATOR-CURRICULUM TRAININ	08/06/2025
KROEKER, BRIAN SCOTT	BLUE VALLEY WEST HIGH SCHOOL	DEPARTMENT CHAIR-ART	08/06/2025
KRULIK, JACLYN LEE	BLUE VALLEY NORTH HIGH SCHOOL	ASST DIRECTOR-WINTER MUSICAL	11/16/2025
KRULIK, JACLYN LEE	BLUE VALLEY NORTH HIGH SCHOOL	DIRECTOR-WINTER MUSICAL	11/16/2025
KUHLMAN, JAIME MICHELLE	DISTRICT WIDE	LIMITED SUPPLY 2 OF 3	09/16/2025



Human Resources Report to the Board of Education

Addendum

October 13, 2025

Administration recommends approval of the following actions:

LABELLE, EMILY C	PRAIRIE STAR MIDDLE SCHOOL	SUPERVISOR-1/2 HR LUNCHROOM	08/06/2025
LAHASKY, ALEX W	BLUE VALLEY WEST HIGH SCHOOL	ADDL TEACHING PLAN-YEAR	08/06/2025
LAHASKY, ALEX W	BLUE VALLEY WEST HIGH SCHOOL	DEPARTMENT CHAIR-SOC SCIENCE	08/06/2025
LAHASKY, JENNIFER LYNN	LEAWOOD MIDDLE SCHOOL	SUPERVISOR-1/2 HR LUNCHROOM	08/06/2025
LANG, PAIGE M	DISTRICT WIDE	LIMITED SUPPLY 2 OF 3	09/16/2025
LANGE, CORBY NELSON	BLUE VALLEY NORTHWEST HS	12 EXTENDED DAYS-DEPT CHAIR	08/06/2025
LANGE, CORBY NELSON	BLUE VALLEY NORTHWEST HS	DEPARTMENT CHAIR-SOC SCIENCE	08/06/2025
LANGE, CORBY NELSON	VIRTUAL ED	VIRTUAL EDUCATION-FALL	08/06/2025
LAUNIUS, RACHEL CHRISTINE	DISTRICT WIDE	LIMITED SUPPLY 1 OF 3	11/17/2025
LAVALLEY, CHRISTINE ANN	BLUE VALLEY NORTHWEST HS	8 EXTENDED DAYS-DEPT CHAIR	08/06/2025
LAVALLEY, CHRISTINE ANN	BLUE VALLEY NORTHWEST HS	DEPARTMENT CHAIR-ART	08/06/2025
LEBAR, JOSEPH S	DISTRICT WIDE	LIMITED SUPPLY 2 OF 3	09/16/2025
LEFEVRE, MICHELLE LAUREN	BLUE VALLEY NORTHWEST HS	COORDINATOR-GRADE LEVEL	08/06/2025
LEFEVRE, MICHELLE LAUREN	DISTRICT WIDE	LIMITED SUPPLY 3 OF 3	09/16/2025
LEGROTTE, JENNIFER CARRIE	BLUE VALLEY WEST HIGH SCHOOL	ADDL TEACHING SUPV-YEAR	08/06/2025
LEIGHTON, KYLA J	BLUE VALLEY ACADEMY	SUPERVISOR-LUNCHROOM	08/06/2025
LENERTZ, OLIVIA KATHRYN	BLUE VALLEY NORTH HIGH SCHOOL	12 EXTENDED DAYS-DEPT CHAIR	08/06/2025
LENERTZ, OLIVIA KATHRYN	BLUE VALLEY NORTH HIGH SCHOOL	DEPARTMENT CHAIR-MATH	08/06/2025
LERDAL, SARAH DOROTHY	BLUE VALLEY WEST HIGH SCHOOL	COORDINATOR-GRADE LEVEL	08/06/2025
LEVIN, AMANDA ROSE	BLUE VALLEY NORTH HIGH SCHOOL	DEPARTMENT CHAIR-COUNSELOR	08/06/2025
LEVY, BENJAMIN JOSEPH	BLUE VALLEY NORTH HIGH SCHOOL	DEPARTMENT CHAIR-BUSINESS	08/06/2025
LEVY, JAMES M	OVERLAND TRAIL MIDDLE SCHOOL	SUPERVISOR-1/2 HR LUNCHROOM	08/06/2025
LEW, MOI MOOI	VALLEY PARK ELEMENTARY	ADDL TEACHING CI-YEAR	08/06/2025
LI, PAULA L	DISTRICT WIDE	LIMITED SUPPLY 3 OF 3	09/16/2025
LIND, LISA J	DISTRICT WIDE	LIMITED SUPPLY 3 OF 3	09/16/2025
LINTZ, PATRICIA JEAN	DISTRICT WIDE	LIMITED SUPPLY 2 OF 3	09/16/2025
LIU, ELAINE G	WOLF SPRINGS ELEMENTARY	ADDL TEACHING CI-YEAR	08/06/2025
LISTER, BRIDGET BAKER	HARMONY MIDDLE SCHOOL	ASST COACH-TRACK	03/01/2026
LISTER, BRIDGET BAKER	HARMONY MIDDLE SCHOOL	SUPERVISOR-1/2 HR LUNCHROOM	08/06/2025
LONG, JERALD ANDREW	PLEASANT RIDGE MIDDLE SCHOOL	SUPERVISOR-1/2 HR LUNCHROOM	08/06/2025
LOVGREN-URIBE, SAMANTHA D	EDUCATIONAL SUPPORT CENTER	CLIN FELLOW YR SUPV STIP-SLP	08/06/2025
LOWE, STACI LEA	BLUE VALLEY WEST HIGH SCHOOL	ADDL TEACHING PLAN-YEAR	08/06/2025
LUAL, BUOMKUOTH P	OVERLAND TRAIL MIDDLE SCHOOL	SUPERVISOR-1/2 HR LUNCHROOM	08/06/2025
LUEDERS, MCKENZIE K	CENTER FOR ADV PROF STUDIES	ADDL TEACHING RESPONSIBILITIES	08/06/2025
LUEDERS, MCKENZIE K	CENTER FOR ADV PROF STUDIES	CAPS BUSINESS PARTNERSHIP	08/06/2025
LUEDERS, MCKENZIE K	DISTRICT WIDE	FACILITATOR-CURRICULUM TRAININ	08/06/2025
LUNDINE, ADAM HARLAN	EDUCATIONAL SUPPORT CENTER	DIRECTOR-BAND DL	08/06/2025
LUNDINE, ADAM HARLAN	EDUCATIONAL SUPPORT CENTER	DIRECTOR-ORCHESTRA	08/06/2025
LUNDINE, ADAM HARLAN	EDUCATIONAL SUPPORT CENTER	DIRECTOR-VOCAL MUSIC	08/06/2025
LUNSFORD, CARA GLENN	BLUE VALLEY WEST HIGH SCHOOL	COORDINATOR-BUILDING ADVISORY	08/06/2025
LYNCH, COURTNEY MARY ELIZABETH	OXFORD MIDDLE SCHOOL	ASST DIRECTOR-FALL PLAY	08/16/2025
LYNN, JENNIFER ELIZABETH	DISTRICT WIDE	LIMITED SUPPLY 3 OF 3	09/16/2025
LYON, ROBIN L	EDUCATIONAL SUPPORT CENTER	CLIN FELLOW YR SUPV STIP-SLP	08/06/2025
LYON, ROBIN L	DISTRICT WIDE	LEADERSHIP STIPEND-SLP	08/06/2025



Human Resources Report to the Board of Education

Addendum

October 13, 2025

Administration recommends approval of the following actions:

MAASEN, ANGELA JEAN	VIRTUAL ED	VIRTUAL EDUCATION-FALL	08/06/2025
MACDONNELL, NICHOLAS	BLUE VALLEY WEST HIGH SCHOOL	ADDL TEACHING SUPV-YEAR	08/06/2025
MADDEN, LILLIAN MARIE	LEAWOOD MIDDLE SCHOOL	SUPERVISOR-1/2 HR LUNCHROOM	08/06/2025
MADDOX, SARA FRANCES	DISTRICT WIDE	LIMITED SUPPLY 3 OF 3	09/16/2025
MADISON, SHANNON LEA	PLEASANT RIDGE MIDDLE SCHOOL	SUPERVISOR-1/2 HR LUNCHROOM	08/06/2025
MADSEN, TRICIA LOUISE	DISTRICT WIDE	DRUG & ALCOHOL COORDINATOR	09/01/2025
MAHONEY, RYAN MICHAEL	BLUE VALLEY NORTHWEST HS	ASST COACH-BOYS BASKETBALL	11/16/2025
MAINS, ANNE ELIZABETH	DISTRICT WIDE	LIMITED SUPPLY 2 OF 3	09/16/2025
MANN, KALE HAMPTON	BLUE VALLEY HIGH SCHOOL	ADDL TEACHING PLAN-YEAR	08/06/2025
MANNING, ROBERT ALAN	HARMONY MIDDLE SCHOOL	ASST DIRECTOR-SPRING MUSICAL	11/16/2025
MANTIA, CHLOE A	DISTRICT WIDE	LIMITED SUPPLY 3 OF 3	09/16/2025
MARSHALL, ZAKIAH	DISTRICT WIDE	LIMITED SUPPLY 2 OF 3	09/16/2025
MARTENS, LAUREN	AUBRY BEND MIDDLE SCHOOL	ADDL TEACHING RESPONSIBILITIES	08/06/2025
MARTINEZ, BRADLEY MARTIN	BLUE VALLEY SOUTHWEST HS	ASST DIRECTOR-MARCHING BAND	08/16/2025
MASON, ALLISON MICHELLE	PLEASANT RIDGE MIDDLE SCHOOL	SUPERVISOR-1/2 HR LUNCHROOM	08/06/2025
MASON, LAURA ELIZABETH	BLUE VALLEY SOUTHWEST HS	COORDINATOR-GRADE LEVEL	08/06/2025
MAY, DANIELLE K	BLUE VALLEY WEST HIGH SCHOOL	ADDL TEACHING PLAN-YEAR	08/06/2025
MAY, DANIELLE K	DISTRICT WIDE	FACILITATOR-CURRICULUM TRAININ	08/06/2025
MCCARTY, MAXWELL PORTER	BLUE VALLEY NORTH HIGH SCHOOL	ASST COACH-DEBATE	08/16/2025
MCCARTY, PATRICK M	BLUE VALLEY NORTH HIGH SCHOOL	DIRECTOR-PEP BAND	11/16/2025
MCKEE, IAIN JOSEPH	OXFORD MIDDLE SCHOOL	SUPERVISOR-1/2 HR LUNCHROOM	08/06/2025
MCKEE, SARAH MARGARET	BLUE VALLEY SOUTHWEST HS	DEPARTMENT CHAIR-ART	08/06/2025
MCLAUGHLIN, TANNER D	DISTRICT WIDE	BCBA CERTIFICATION	08/06/2025
MEEK, STEPHANIE A	PLEASANT RIDGE MIDDLE SCHOOL	SUPERVISOR-1/2 HR LUNCHROOM	08/06/2025
MEISINGER, PEYTON JEAN	DISTRICT WIDE	BCBA CERTIFICATION	08/06/2025
MELTON, ANGELA LYN	HEARTLAND ELEMENTARY	ADDL TEACHING RESPONSIBILITIES	08/06/2025
MILLER, CARRIE LYNN	PLEASANT RIDGE MIDDLE SCHOOL	SUPERVISOR-1/2 HR LUNCHROOM	08/06/2025
MILLS, HEATHER L	PLEASANT RIDGE MIDDLE SCHOOL	SPONSOR-DIVERSITY CLUB	08/06/2025
MITCHELSON, KAYLEE JANE	HARMONY MIDDLE SCHOOL	ASST DIRECTOR-FALL PLAY	08/16/2025
MITCHELSON, KAYLEE JANE	HARMONY MIDDLE SCHOOL	ASST DIRECTOR-SPRING MUSICAL	11/16/2025
MODELSKI, KIMBERLY ANN	BLUE VALLEY WEST HIGH SCHOOL	DEPARTMENT CHAIR-PERFORM ARTS	08/06/2025
MOHN, JEREMY J	DISTRICT WIDE	NATIONAL BOARD CERTIFICATION	08/06/2025
MOLDE, MELISSA C	PRAIRIE STAR MIDDLE SCHOOL	16 EXTENDED DAYS-IDC	08/06/2025
MOLDE, MELISSA C	LEAWOOD MIDDLE SCHOOL	16 EXTENDED DAYS-IDC	08/06/2025
MOLDE, MELISSA C	PRAIRIE STAR MIDDLE SCHOOL	LEADERSHIP TEAM MEMBER	08/06/2025
MOLDE, MELISSA C	LEAWOOD MIDDLE SCHOOL	LEADERSHIP TEAM MEMBER	08/06/2025
MONSON, ANDREW JAMES	PLEASANT RIDGE MIDDLE SCHOOL	ADDL TEACHING RESPONSIBILITIES	08/06/2025
MONTGOMERY, MORGAN LYNN	DISTRICT WIDE	BCBA CERTIFICATION	08/06/2025
MOORE, CANDY DIANE	DISTRICT WIDE	DRUG & ALCOHOL COORDINATOR	09/01/2025
MORGAN, ERIN ASHLEIGH	BLUE VALLEY NORTH HIGH SCHOOL	ADDL TEACHING SUPV-YEAR	08/06/2025
MOSS, ELIJAH COLEMAN	AUBRY BEND MIDDLE SCHOOL	SUPERVISOR-1/2 HR LUNCHROOM	08/06/2025
MOWRY, BRIAN JAMES	BLUE VALLEY HIGH SCHOOL	DEPARTMENT CHAIR-SOC SCIENCE	08/06/2025
MUELLER, LOGAN C	DISTRICT WIDE	LIMITED SUPPLY 3 OF 3	09/16/2025
MUNSON, REBECCA STITH	DISTRICT WIDE	NATIONAL BOARD CERTIFICATION	08/06/2025



Human Resources Report to the Board of Education

Addendum

October 13, 2025

Administration recommends approval of the following actions:

MURKIN, HALEY N	DISTRICT WIDE	LIMITED SUPPLY 3 OF 3	09/16/2025
MURRAIN, LAUREN ROSE	DISTRICT WIDE	LIMITED SUPPLY 2 OF 3	09/16/2025
NATARAJAN, RAMA	HARMONY MIDDLE SCHOOL	ASST SPONSOR-SCIENCE OLYMPIAD	09/11/2025
NATHAN, ERIN LEA	BLUE VALLEY NORTH HIGH SCHOOL	COORDINATOR-GRADE LEVEL	08/06/2025
NAVARRO, NICOLAS ALEXANDER	BLUE VALLEY NORTH HIGH SCHOOL	ASST COACH-BOYS SOCCER	08/16/2025
NEWELL, LUCAS A	OVERLAND TRAIL MIDDLE SCHOOL	SUPERVISOR-1/2 HR LUNCHROOM	08/06/2025
NEWELL, LUCAS A	VIRTUAL ED	VIRTUAL EDUCATION-FALL	08/06/2025
NEWELL, ROSS WHITNEY	HARMONY MIDDLE SCHOOL	ASST COACH-BOYS BASKETBALL	11/16/2025
NEWELL, ROSS WHITNEY	HARMONY MIDDLE SCHOOL	ASST COACH-GIRLS BASKETBALL	11/16/2025
NEWELL, ROSS WHITNEY	HARMONY MIDDLE SCHOOL	ASST COACH-TRACK	03/01/2026
NEWELL, ROSS WHITNEY	HARMONY MIDDLE SCHOOL	SUPERVISOR-1/2 HR LUNCHROOM	08/06/2025
NEWTON, CHELSI ANN	DISTRICT WIDE	LIMITED SUPPLY 3 OF 3	09/16/2025
NIE, JUNYI	BLUE VALLEY HIGH SCHOOL	ASST DIRECTOR-FALL MUSICAL	08/16/2025
NOCITA, LISA THOMAS	DISTRICT WIDE	NATIONAL BOARD CERTIFICATION	08/06/2025
NOCITA, LISA THOMAS	PRAIRIE STAR MIDDLE SCHOOL	SUPERVISOR-1/2 HR LUNCHROOM	08/06/2025
NORVAL, ALEXANDRIA NICOLE	DISTRICT WIDE	LIMITED SUPPLY 2 OF 3	09/16/2025
O'BRYAN, DIANNE LYNN	BLUE VALLEY HIGH SCHOOL	ADDL TEACHING RESPONSIBILITIES	08/06/2025
O'BRYAN, DIANNE LYNN	BLUE VALLEY HIGH SCHOOL	DEPARTMENT CHAIR-COORD TCHR	08/06/2025
O'CONNELL, LAURA GRACE	BLUE VALLEY NORTH HIGH SCHOOL	COORDINATOR-GRADE LEVEL	08/06/2025
O'GORMAN, MICHAEL M	LEAWOOD MIDDLE SCHOOL	SUPERVISOR-1/2 HR LUNCHROOM	08/06/2025
O'KEEFE, NICHOLAS RYAN	BLUE VALLEY SOUTHWEST HS	ADDL TEACHING PLAN-YEAR	08/06/2025
O'KEEFE, NICHOLAS RYAN	DISTRICT WIDE	LIMITED SUPPLY 2 OF 3	09/16/2025
O'LEARY, KATELYN HANNAH	DISTRICT WIDE	BCBA CERTIFICATION	08/06/2025
OCON JR, JUAN	BLUE VALLEY NORTH HIGH SCHOOL	ADDL TEACHING PLAN-YEAR	08/06/2025
ODDO, KATHRYN ELIZABETH	HARMONY ELEMENTARY	AD INTERN SUPERVISION DUTIES	08/06/2025
ODLE, CRAIG TAYLOR	BLUE VALLEY NORTHWEST HS	3 EXTENDED DAYS-DEPT CHAIR	08/06/2025
ODLE, CRAIG TAYLOR	BLUE VALLEY NORTHWEST HS	DEPARTMENT CHAIR-LIBRARY	08/06/2025
OGLE, MADELINE ELLEN	BLUE VALLEY WEST HIGH SCHOOL	ASST COACH-TRACK	03/01/2026
OLDSON, MCKENNA LEE	HARMONY MIDDLE SCHOOL	SUPERVISOR-1/2 HR LUNCHROOM	08/06/2025
OLLIG, CHRIS B	BLUE VALLEY NORTH HIGH SCHOOL	DEPARTMENT CHAIR-SCIENCE	08/06/2025
OLNEY, BRANDON JAMES	DISTRICT WIDE	LIMITED SUPPLY 2 OF 3	09/16/2025
ORRICK, ANTHONY JOHN	BLUE VALLEY SOUTHWEST HS	4 EXTENDED DAYS-DEPT CHAIR	08/06/2025
ORRICK, ANTHONY JOHN	BLUE VALLEY SOUTHWEST HS	ADDL TEACHING SUPV-2ND SEM	01/05/2026
ORRICK, ANTHONY JOHN	BLUE VALLEY SOUTHWEST HS	DEPARTMENT CHAIR-PE	08/06/2025
ORTIZ, DENISE A	DISTRICT WIDE	LIMITED SUPPLY 3 OF 3	09/16/2025
OSBORNE, KATELYN A	DISTRICT WIDE	LIMITED SUPPLY 2 OF 3	09/16/2025
OSTERTAG, HANNAH SUE	DISTRICT WIDE	LIMITED SUPPLY 3 OF 3	09/16/2025
PALERMO, CHERIN LYNN	DISTRICT WIDE	NATIONAL BOARD CERTIFICATION	08/06/2025
PALMGREN JR, ROBERT MICHAEL	BLUE VALLEY SOUTHWEST HS	DEPARTMENT CHAIR-FOREIGN LNG	08/06/2025
PARKER, HALEY NICOLE	DISTRICT WIDE	BCBA CERTIFICATION	08/06/2025
PARKER, KATHRYN ANN	DISTRICT WIDE	LIMITED SUPPLY 2 OF 3	09/16/2025
PARKS, KATIE ROSE BARTOLAC	DISTRICT WIDE	LIMITED SUPPLY 1 OF 3	09/16/2025
PATINO-JIMENEZ, JUAN MANUEL	DISTRICT WIDE	NATIONAL BOARD CERTIFICATION	08/06/2025
PAYNE, HEATHER LYNN	WOLF SPRINGS ELEMENTARY	AD INTERN SUPERVISION DUTIES	08/06/2025



Human Resources Report to the Board of Education

Addendum

October 13, 2025

Administration recommends approval of the following actions:

PEARSON, ERIN K	BLUE VALLEY NORTHWEST HS	ADDL TEACHING PLAN-YEAR	08/06/2025
PEARSON, ERIN K	DISTRICT WIDE	NATIONAL BOARD CERTIFICATION	08/06/2025
PEARSON, KATHRYN IDA ANN	BLUE VALLEY NORTH HIGH SCHOOL	AD INTERN SUPERVISION DUTIES	08/06/2025
PERES, KATHY L	BLUE VALLEY HIGH SCHOOL	DEPARTMENT CHAIR-BUSINESS	08/06/2025
PERES, KATHY L	DISTRICT WIDE	FACILITATOR-CURRICULUM TRAININ	08/06/2025
PETERSEN, TODD MITCHELL	BLUE VALLEY NORTHWEST HS	12 EXTENDED DAYS-DEPT CHAIR	08/06/2025
PETERSEN, TODD MITCHELL	BLUE VALLEY NORTHWEST HS	DEPARTMENT CHAIR-COMM ARTS	08/06/2025
PHILLIPS, TATUM NICOLE	BLUE VALLEY MIDDLE SCHOOL	SPONSOR-DRILL/DANCE TEAM	08/06/2025
PHROMMANY, MACKENZIE ADAM	DISTRICT WIDE	LIMITED SUPPLY 2 OF 3	09/16/2025
PICKERT, AZADEH TAGHIZADEH	BLUE VALLEY HIGH SCHOOL	DEPARTMENT CHAIR-COORD TCHR	08/06/2025
PICKERT, AZADEH TAGHIZADEH	BLUE VALLEY HIGH SCHOOL	DEPARTMENT CHAIR-SCIENCE	08/06/2025
PINKER, JONATHAN ELTON	DISTRICT WIDE	LIMITED SUPPLY 2 OF 3	09/16/2025
PINKER, JONATHAN ELTON	AUBRY BEND MIDDLE SCHOOL	SUPERVISOR-1/2 HR LUNCHROOM	08/06/2025
PITTMAN, JOSEPH KEIL	VIRTUAL ED	VIRTUAL EDUCATION-FALL	08/06/2025
PORTER, ANNA NICOLE	BLUE VALLEY NORTH HIGH SCHOOL	8 EXTENDED DAYS-DEPT CHAIR	08/06/2025
PORTER, ANNA NICOLE	BLUE VALLEY NORTH HIGH SCHOOL	DEPARTMENT CHAIR-SPED	08/06/2025
PRAKASH, RAJASREE	BLUE VALLEY NORTH HIGH SCHOOL	ADDL TEACHING PLAN-YEAR	08/06/2025
PRATER, LINDSAY CARTHLEENA	BLUE RIVER ELEMENTARY	DIRECTOR-CHOIR	08/06/2025
PREDMORE-SOPER, PATRICIA M	HARMONY MIDDLE SCHOOL	SUPERVISOR-1/2 HR LUNCHROOM	08/06/2025
QUINN, ROXANNE HAZEL	OVERLAND TRAIL MIDDLE SCHOOL	SUPERVISOR-1/2 HR LUNCHROOM	08/06/2025
RAMIREZ, JENNA RENEE	HILLTOP LEARNING CENTER	ADDL TEACHING RESPONSIBILITIES	08/06/2025
RAMSEY, LORI ANN	WOLF SPRINGS ELEMENTARY	ADDL TEACHING CI-YEAR	08/06/2025
RASTOGI, SARAH ANN	LEAWOOD MIDDLE SCHOOL	HEAD SPONSOR-SCIENCE OLYMPIAD	09/19/2025
RATHBONE, BRODERIC R	LEAWOOD MIDDLE SCHOOL	SUPERVISOR-1/2 HR LUNCHROOM	08/06/2025
RAY, KRISTIN MICHELLE	DISTRICT WIDE	NATIONAL BOARD CERTIFICATION	08/06/2025
REDLIN, MAKAELE ANN	AUBRY BEND MIDDLE SCHOOL	SUPERVISOR-1/2 HR LUNCHROOM	08/06/2025
REEVES, ANDREW LAMAR	DISTRICT WIDE	FACILITATOR-CURRICULUM TRAININ	08/06/2025
REGIER, ERIC C	DISTRICT WIDE	LIMITED SUPPLY 3 OF 3	09/16/2025
REICHART, JOHN KEVIN	BLUE VALLEY NORTHWEST HS	3 EXTENDED DAYS-DEPT CHAIR	08/06/2025
REICHART, JOHN KEVIN	BLUE VALLEY NORTHWEST HS	DEPARTMENT CHAIR-PE	08/06/2025
REICHART, JOHN KEVIN	BLUE VALLEY NORTHWEST HS	SUPERVISOR-LUNCHROOM	08/06/2025
RESTIVO, LAURA M	BLUE VALLEY WEST HIGH SCHOOL	ADDL TEACHING PLAN-YEAR	08/06/2025
RESTIVO, LAURA M	BLUE VALLEY WEST HIGH SCHOOL	DEPARTMENT CHAIR-COMM ARTS	08/06/2025
REXROAT, ANDREW WILLIAM	DISTRICT WIDE	LIMITED SUPPLY 2 OF 3	09/16/2025
REYNOLDS, TINA DENAY	PRAIRIE STAR MIDDLE SCHOOL	SUPERVISOR-1/2 HR LUNCHROOM	08/06/2025
RICHARDS, CHRISTINE ROBERTA	PRAIRIE STAR MIDDLE SCHOOL	SUPERVISOR-1/2 HR LUNCHROOM	08/06/2025
RICKE, ELIZABETH ANNE	BLUE VALLEY NORTHWEST HS	4 EXTENDED DAYS-DEPT CHAIR	08/06/2025
RICKE, ELIZABETH ANNE	BLUE VALLEY NORTHWEST HS	DEPARTMENT CHAIR-COUNSELOR	08/06/2025
RIFFER, JILL C	CENTER FOR ADV PROF STUDIES	ADDL TEACHING RESPONSIBILITIES	08/06/2025
RIFFER, JILL C	CENTER FOR ADV PROF STUDIES	CAPS BUSINESS PARTNERSHIP	08/06/2025
RIFFER, JILL C	CENTER FOR ADV PROF STUDIES	CAPS STRAND LEADER	08/06/2025
RILEY, MILES ALEXANDER	CENTER FOR ADV PROF STUDIES	8 EXTENDED DAYS-STRAND LEADER	08/06/2025
RILEY, MILES ALEXANDER	CENTER FOR ADV PROF STUDIES	ADDL TEACHING RESPONSIBILITIES	08/06/2025
RILEY, MILES ALEXANDER	CENTER FOR ADV PROF STUDIES	CAPS BUSINESS PARTNERSHIP	08/06/2025



Human Resources Report to the Board of Education

Addendum

October 13, 2025

Administration recommends approval of the following actions:

RILEY, MILES ALEXANDER	CENTER FOR ADV PROF STUDIES	CAPS STRAND LEADER	08/06/2025
RILEY, MILES ALEXANDER	DISTRICT WIDE	FACILITATOR-CURRICULUM TRAININ	08/06/2025
RINDOM, HALLEY ANN	DISTRICT WIDE	LIMITED SUPPLY 3 OF 3	09/16/2025
RINEARSON, SHAUNA CHRISTINE	BLUE VALLEY SOUTHWEST HS	DEPARTMENT CHAIR-COMM ARTS	08/06/2025
RINEARSON, SHAUNA CHRISTINE	DISTRICT WIDE	NATIONAL BOARD CERTIFICATION	08/06/2025
RING, TINA LYNN	DISTRICT WIDE	LIMITED SUPPLY 3 OF 3	09/16/2025
RITZEL, MICHAEL E	DISTRICT WIDE	LIMITED SUPPLY 3 OF 3	09/16/2025
ROBERTS, MEGAN BLOOM	DISTRICT WIDE	NATIONAL BOARD CERTIFICATION	08/01/2025
ROBINSON, ERIN JO	BLUE VALLEY ACADEMY	SUPERVISOR-LUNCHROOM	08/06/2025
ROCHE, LEAH M	CENTER FOR ADV PROF STUDIES	ADDL TEACHING RESPONSIBILITIES	08/06/2025
ROCHE, LEAH M	CENTER FOR ADV PROF STUDIES	CAPS BUSINESS PARTNERSHIP	08/06/2025
RONDEAU, LESLIE MORGAN	DISTRICT WIDE	LIMITED SUPPLY 2 OF 2	09/16/2025
ROSE, JESSICA LAUREN	DISTRICT WIDE	LIMITED SUPPLY 3 OF 3	09/16/2025
ROSENBERG, SUSAN S	DISTRICT WIDE	NATIONAL BOARD CERTIFICATION	08/06/2025
RUTHERFORD, PAMELA ROSE	PLEASANT RIDGE MIDDLE SCHOOL	SUPERVISOR-1/2 HR LUNCHROOM	08/06/2025
RUTHERFORD, PAMELA ROSE	VIRTUAL ED	VIRTUAL EDUCATION-FALL	08/06/2025
SAFFELS, HILLARY ANN	DISTRICT WIDE	COORDINATOR-ART	08/06/2025
SALIMBENE, ANN ELIZABETH	BLUE VALLEY NORTH HIGH SCHOOL	12 EXTENDED DAYS-DEPT CHAIR	08/06/2025
SALIMBENE, ANN ELIZABETH	BLUE VALLEY NORTH HIGH SCHOOL	DEPARTMENT CHAIR-SOC SCIENCE	08/06/2025
SAMPLE, JENNIFER D	LAKEWOOD MIDDLE SCHOOL	SUPERVISOR-1/2 HR LUNCHROOM	08/06/2025
SAMPLE, TOBIN JOSEPH	VIRTUAL ED	VIRTUAL EDUCATION-FALL	08/06/2025
SAMUEL, JANELLE MARIE	OVERLAND TRAIL MIDDLE SCHOOL	SUPERVISOR-1/2 HR LUNCHROOM	08/06/2025
SANDERS III, ROBERT LEROY	HARMONY MIDDLE SCHOOL	ASST COACH-BOYS BASKETBALL	11/16/2025
SANDERS III, ROBERT LEROY	HARMONY MIDDLE SCHOOL	SUPERVISOR-1/2 HR LUNCHROOM	08/06/2025
SANDMOEN, SLOANE MILLIKEN	VALLEY PARK ELEMENTARY	ADDL TEACHING CI-YEAR	08/06/2025
SANTEE, MARCY M	LAKEWOOD MIDDLE SCHOOL	LEADERSHIP TEAM MEMBER	08/06/2025
SANTEE, MARCY M	LAKEWOOD MIDDLE SCHOOL	TEAM LEADER-GRADE 6	08/06/2025
SANTIAGO, FRANCISCO JAVIER	DISTRICT WIDE	LIMITED SUPPLY 2 OF 3	09/16/2025
SANTIAGO, NATALIA JULIETA	DISTRICT WIDE	LIMITED SUPPLY 2 OF 3	09/16/2025
SATTLER, TYLER E	BLUE VALLEY MIDDLE SCHOOL	CRD-STUDENT & COMM ENGAGEMENT	08/06/2025
SATTLER, TYLER E	DISTRICT WIDE	LIMITED SUPPLY 3 OF 3	09/16/2025
SATTLER, TYLER E	BLUE VALLEY MIDDLE SCHOOL	SUPERVISOR-1/2 HR LUNCHROOM	08/06/2025
SAULSBERRY, JOHNNEA C	DISTRICT WIDE	LEADERSHIP STIPEND-OT	08/06/2025
SAULSBERRY, JOHNNEA C	EDUCATIONAL SUPPORT CENTER	MENTOR-NEW TO BV OT	08/06/2025
SCHAAKE, SHARI	BLUE VALLEY SOUTHWEST HS	DEPARTMENT CHAIR-COUNSELOR	08/06/2025
SCHEUFLER, ASHLEY LYNN	DISTRICT WIDE	LIMITED SUPPLY 3 OF 3	09/16/2025
SCHNEEBERGER, CAROL HENDERSON	DISTRICT WIDE	LIMITED SUPPLY 3 OF 3	09/16/2025
SCHULTE, AMY H	BLUE VALLEY NORTH HIGH SCHOOL	ADDL TEACHING PLAN-YEAR	08/06/2025
SCHUTZEL, SUCHUN AMY	WOLF SPRINGS ELEMENTARY	ADDL TEACHING CI-YEAR	08/06/2025
SCOTT, CARRIE SUE	OXFORD MIDDLE SCHOOL	SUPERVISOR-1/2 HR LUNCHROOM	08/06/2025
SECRET, SHAWN KATHLEEN	PLEASANT RIDGE MIDDLE SCHOOL	SUPERVISOR-1/2 HR LUNCHROOM	08/06/2025
SEMANKO, CHARLES JOSEPH	DISTRICT WIDE	LIMITED SUPPLY 2 OF 3	09/16/2025
SERBOUSEK, TIMOTHY LYNN	OXFORD MIDDLE SCHOOL	HEAD COACH-WRESTLING BOYS	11/16/2025
SERBOUSEK, TIMOTHY LYNN	OXFORD MIDDLE SCHOOL	HEAD COACH-WRESTLING GIRLS	11/16/2025



Human Resources Report to the Board of Education

Addendum

October 13, 2025

Administration recommends approval of the following actions:

SETTLE, COLIN CRAIG	BLUE VALLEY SOUTHWEST HS	HEAD COACH-BOYS TENNIS	03/01/2026
SHANNON, NATALIE LYNN	BLUE VALLEY NORTHWEST HS	ASST SPONSOR-CHEERLEADING	08/06/2025
SHANNON, NATALIE LYNN	AUBRY BEND MIDDLE SCHOOL	SUPERVISOR-1/2 HR LUNCHROOM	08/06/2025
SHARP, DAVID CHRISTOPHER	OVERLAND TRAIL MIDDLE SCHOOL	ADMIN CONSULTANT SUPV STIP	08/06/2025
SHARTZER, ABIGAIL MARIE	BLUE VALLEY WEST HIGH SCHOOL	SUPERVISOR-LUNCHROOM	08/06/2025
SHOEMAKER, PAIGE AMANDA	BLUE VALLEY NORTH HIGH SCHOOL	DEPARTMENT CHAIR-FACS	08/06/2025
SHOEMAKER, PAIGE AMANDA	DISTRICT WIDE	FACILITATOR-CURRICULUM TRAININ	08/06/2025
SHOEMAKER, PAIGE AMANDA	BLUE VALLEY NORTH HIGH SCHOOL	HEAD SPONSOR-CHEERLEADING	08/06/2025
SIEPERDA, TAYLOR ELAINE	OVERLAND TRAIL MIDDLE SCHOOL	HEAD COACH-GIRLS TRACK	03/01/2026
SIEPERDA, TAYLOR ELAINE	OVERLAND TRAIL MIDDLE SCHOOL	SUPERVISOR-1/2 HR LUNCHROOM	08/06/2025
SIGNER, JENNIFER L	BLUE VALLEY WEST HIGH SCHOOL	ADDL TEACHING SUPV-YEAR	08/06/2025
SIMER, KATHERINE FRANCES	DISTRICT WIDE	BCBA CERTIFICATION	08/06/2025
SINCLAIR-KING, CRYSTAL L	DISTRICT WIDE	LIMITED SUPPLY 3 OF 3	09/16/2025
SKAKAL, CHELSE RENAE	BLUE VALLEY WEST HIGH SCHOOL	ADDL TEACHING PLAN-YEAR	08/06/2025
SKEENS, WILLIAM ALLEN	CENTER FOR ADV PROF STUDIES	ADDL TEACHING RESPONSIBILITIES	08/06/2025
SKEENS, WILLIAM ALLEN	CENTER FOR ADV PROF STUDIES	CAPS BUSINESS PARTNERSHIP	08/06/2025
SMITH, ANDREA MELI	BLUE VALLEY NORTHWEST HS	8 EXTENDED DAYS-DEPT CHAIR	08/06/2025
SMITH, ANDREA MELI	BLUE VALLEY NORTHWEST HS	DEPARTMENT CHAIR-FOREIGN LNG	08/06/2025
SMITH, BLAISE	DISTRICT WIDE	LIMITED SUPPLY 2 OF 3	09/16/2025
SMITH, JENNIFER REBECCA	DISTRICT WIDE	DIST CRD-STUDENT & COMM ENGMNT	08/06/2025
SMITH, JENNIFER REBECCA	DISTRICT WIDE	NATIONAL BOARD CERTIFICATION	08/06/2025
SMITHYMAN, WILLIAM EDWARD	BLUE VALLEY WEST HIGH SCHOOL	ADDL TEACHING PLAN-YEAR	08/06/2025
SMITHYMAN, WILLIAM EDWARD	DISTRICT WIDE	NATIONAL BOARD CERTIFICATION	08/06/2025
SNODGRASS, REBECCA JO	CENTER FOR ADV PROF STUDIES	ADDL TEACHING RESPONSIBILITIES	08/06/2025
SNODGRASS, REBECCA JO	CENTER FOR ADV PROF STUDIES	CAPS BUSINESS PARTNERSHIP	08/06/2025
SO, HOLLY H	WOLF SPRINGS ELEMENTARY	ADDL TEACHING CI-YEAR	08/06/2025
SOMOGYE, JESSICA C	BLUE VALLEY NORTH HIGH SCHOOL	SPONSOR-LITERARY MAGAZINE	08/06/2025
SOMOGYE, JESSICA C	BLUE VALLEY NORTH HIGH SCHOOL	SPONSOR-NATL CURRIC HONOR SOC	08/06/2025
SPADONI, SHANNON RAE VAIL	DISTRICT WIDE	LIMITED SUPPLY 2 OF 3	09/16/2025
SPIEKER, DAVID ANTHONY	PLEASANT RIDGE MIDDLE SCHOOL	HEAD SPONSOR-SCIENCE OLYMPIAD	09/22/2025
STAINES, RYAN MICHAEL	BLUE VALLEY NORTH HIGH SCHOOL	DIRECTOR-PEP BAND	11/16/2025
STALLBAUMER, KRISTIN ANN	BLUE VALLEY HIGH SCHOOL	COORDINATOR-GRADE LEVEL	08/06/2025
STALLBAUMER, KRISTIN ANN	BLUE VALLEY HIGH SCHOOL	DEPARTMENT CHAIR-COUNSELOR	08/06/2025
STANFIELD, PATRICIA LEE	PLEASANT RIDGE MIDDLE SCHOOL	SUPERVISOR-1/2 HR LUNCHROOM	08/06/2025
STANG, AUSTIN JAMES	BLUE VALLEY NORTH HIGH SCHOOL	ASST DIRECTOR-WINTER MUSICAL	11/16/2025
STANLEY, MICHAEL SCOTT	DISTRICT WIDE	LIMITED SUPPLY 3 OF 3	09/16/2025
STANWAY, SHELBY GRACE	DISTRICT WIDE	LIMITED SUPPLY 2 OF 3	09/16/2025
STEENSON, EMILY MCGEE	DISTRICT WIDE	LIMITED SUPPLY 2 OF 3	09/16/2025
STEGMAN, MACKENZIE E	DISTRICT WIDE	LIMITED SUPPLY 3 OF 3	09/16/2025
STEIN, SHERYL ILENE	BLUE VALLEY NORTH HIGH SCHOOL	12 EXTENDED DAYS-DEPT CHAIR	08/06/2025
STEIN, SHERYL ILENE	BLUE VALLEY NORTH HIGH SCHOOL	DEPARTMENT CHAIR-MATH	08/06/2025
STEVENS, HANNA MICHELLE	HARMONY MIDDLE SCHOOL	ASST DIRECTOR-SPRING MUSICAL	11/16/2025
STEVENS, HANNAH J	BLUE VALLEY ACADEMY	SUPERVISOR-LUNCHROOM	08/06/2025
STEWART, KASEY MARIE	DISTRICT WIDE	LIMITED SUPPLY 2 OF 3	09/16/2025



Human Resources Report to the Board of Education

Addendum

October 13, 2025

Administration recommends approval of the following actions:

STEWART, OLIVIA ROSE	DISTRICT WIDE	LIMITED SUPPLY 2 OF 3	09/16/2025
STEWART, TAYLOR KYLE	AUBRY BEND MIDDLE SCHOOL	SUPERVISOR-1/2 HR LUNCHROOM	08/06/2025
STOUT, SHAWNA LEIGH	BLUE VALLEY MIDDLE SCHOOL	SUPERVISOR-1/2 HR LUNCHROOM	08/06/2025
STRAWDER, CRYSTAL JOY	DISTRICT WIDE	LIMITED SUPPLY 1 OF 3	09/16/2025
STRAWDER, CRYSTAL JOY	BLUE VALLEY SOUTHWEST HS	TECHNOLOGY STIPEND	08/06/2025
SUHR, KEVIN RAYMOND	BLUE VALLEY MIDDLE SCHOOL	ASST COACH-BOYS BASKETBALL	11/16/2025
SUHR, KEVIN RAYMOND	BLUE VALLEY MIDDLE SCHOOL	SUPERVISOR-1/2 HR LUNCHROOM	08/06/2025
SUHR, SARAH CATHERINE	DISTRICT WIDE	LIMITED SUPPLY 3 OF 3	09/16/2025
SULLIVAN, ATHENA VENEICE	DISTRICT WIDE	NATIONAL BOARD CERTIFICATION	08/06/2025
SUMMERLIN, VICTORIA MARGARET	DISTRICT WIDE	LIMITED SUPPLY 2 OF 3	09/16/2025
SUN, GUONA	VALLEY PARK ELEMENTARY	ADDL TEACHING CI-YEAR	08/06/2025
SUTCLIFFE, TREVOR L	CENTER FOR ADV PROF STUDIES	ADDL TEACHING RESPONSIBILITIES	08/06/2025
SUTCLIFFE, TREVOR L	CENTER FOR ADV PROF STUDIES	CAPS BUSINESS PARTNERSHIP	08/06/2025
SVATOS, DOMINIC JOSEPH	DISTRICT WIDE	LIMITED SUPPLY 3 OF 3	09/16/2025
SWANSON, PATRICK	BLUE VALLEY NORTHWEST HS	ADDL TEACHING PLAN-2ND SEM	01/05/2026
SWARTZ, MIRANDA E	PLEASANT RIDGE MIDDLE SCHOOL	SPONSOR-DIVERSITY CLUB	08/06/2025
TALLEY, SARA FELICITY	DISTRICT WIDE	COORDINATOR-COUNSELING	08/06/2025
TAYLOR, KENNETH DALE	BLUE VALLEY NORTH HIGH SCHOOL	ADDL TEACHING PLAN-YEAR	08/06/2025
TAYLOR, KENNETH DALE	BLUE VALLEY NORTH HIGH SCHOOL	DEPARTMENT CHAIR-COMM ARTS	08/06/2025
TAYLOR, LAURA KATHERINE	BLUE VALLEY WEST HIGH SCHOOL	DEPARTMENT CHAIR-COUNSELOR	08/06/2025
TAYLOR, MARTHA L	DISTRICT WIDE	LIMITED SUPPLY 2 OF 3	09/16/2025
THOMPSON, BRITTON TANNER	BLUE VALLEY MIDDLE SCHOOL	SUPERVISOR-1/2 HR LUNCHROOM	08/06/2025
THOMPSON, DEREK ALLEN	DISTRICT WIDE	DRUG & ALCOHOL COORDINATOR	09/01/2025
THOMPSON, DEREK ALLEN	DISTRICT WIDE	LIMITED SUPPLY 3 OF 3	09/16/2025
THOMPSON, KIMBERLY BRIANNE	BLUE VALLEY HIGH SCHOOL	COORDINATOR-BUILDING ADVISORY	08/06/2025
THURSTON, TRAVIS LLOYD	BLUE VALLEY WEST HIGH SCHOOL	ADDL TEACHING PLAN-YEAR	08/06/2025
TIFFANY, SCOTT CHANDLER	AUBRY BEND MIDDLE SCHOOL	SUPERVISOR-1/2 HR LUNCHROOM	08/06/2025
TODD, AMANDA WREN	BLUE VALLEY SOUTHWEST HS	DEPARTMENT CHAIR-SPED	08/06/2025
TODD, AMANDA WREN	EDUCATIONAL SUPPORT CENTER	DIGITAL ASSESSMENT RESOURCES	08/06/2025
TODD, AMANDA WREN	DISTRICT WIDE	LEADERSHIP STIPEND-PSYCH	08/06/2025
TODD, JEREMY	CENTER FOR ADV PROF STUDIES	ADDL TEACHING RESPONSIBILITIES	08/06/2025
TODD, JEREMY	CENTER FOR ADV PROF STUDIES	CAPS BUSINESS PARTNERSHIP	08/06/2025
TOEPFER, ASHTYN LYNN	LEAWOOD MIDDLE SCHOOL	LEADERSHIP TEAM MEMBER	08/06/2025
TRADER, MEGHAN S	BLUE VALLEY NORTHWEST HS	10 EXTENDED DAYS-DEPT CHAIR	08/06/2025
TRADER, MEGHAN S	BLUE VALLEY NORTHWEST HS	DEPARTMENT CHAIR-CTE	08/06/2025
TRIMBLE, MEGAN M	OXFORD MIDDLE SCHOOL	SUPERVISOR-1/2 HR LUNCHROOM	08/06/2025
TUEL, KELLEY ROCHELLE	CENTER FOR ADV PROF STUDIES	CAPS BUSINESS PARTNERSHIP	08/06/2025
TYNDALL, BETHANY RUTH	DISTRICT WIDE	LIMITED SUPPLY 2 OF 3	09/16/2025
TYSHLEK, EMMA ROSE	DISTRICT WIDE	LIMITED SUPPLY 1 OF 3	09/16/2025
VAN LEEUWEN, KALE H	OVERLAND TRAIL ELEMENTARY	DIRECTOR-CHOIR	08/06/2025
VAN SCOYOC, ELIZABETH ABBOTT	DISTRICT WIDE	LIMITED SUPPLY 3 OF 3	09/16/2025
VODEHNAL, JULIE ANN	DISTRICT WIDE	NATIONAL BOARD CERTIFICATION	08/06/2025
VODEHNAL, JULIE ANN	DISTRICT WIDE	PDC REPRESENTATIVE	08/06/2025
VODEHNAL, MICHAEL PAUL	BLUE VALLEY NORTHWEST HS	ADDL TEACHING PLAN-YEAR	08/06/2025



Human Resources Report to the Board of Education

Addendum

October 13, 2025

Administration recommends approval of the following actions:

VOKAC, BETHANY JANE	DISTRICT WIDE	NATIONAL BOARD CERTIFICATION	08/06/2025
VORNDRAN, DORIS IRENE	DISTRICT WIDE	LIMITED SUPPLY 3 OF 3	09/16/2025
VU, LUKE MINH DANG	BLUE VALLEY NORTHWEST HS	ASST COACH-DEBATE	09/11/2025
WADE, JENNIFER LYN	PRAIRIE STAR MIDDLE SCHOOL	SUPERVISOR-1/2 HR LUNCHROOM	08/06/2025
WAGONER, JOEL DAVID	OVERLAND TRAIL MIDDLE SCHOOL	SUPERVISOR-1/2 HR LUNCHROOM	08/06/2025
WALKER, AUBRIE NORINE	DISTRICT WIDE	BCBA CERTIFICATION	08/06/2025
WALLACE, OLIVIA LITTLEWOOD	BLUE VALLEY WEST HIGH SCHOOL	ADDL TEACHING PLAN-1ST SEM	08/06/2025
WALLACE, OLIVIA LITTLEWOOD	BLUE VALLEY WEST HIGH SCHOOL	SUPERVISOR-LUNCHROOM	08/06/2025
WARNES, TIFFANY NICOLE	BLUE VALLEY WEST HIGH SCHOOL	SUPERVISOR-LUNCHROOM	08/06/2025
WARRICK, MANDI LYNN	LEAWOOD MIDDLE SCHOOL	SUPERVISOR-1/2 HR LUNCHROOM	08/06/2025
WASINGER, RICK W	BLUE VALLEY NORTH HIGH SCHOOL	SUPERVISOR-GYMNASIUM	11/16/2025
WATSON, CASEY JOHN	OVERLAND TRAIL MIDDLE SCHOOL	SUPERVISOR-1/2 HR LUNCHROOM	08/06/2025
WATTS, RACHEL LUCILLE	DISTRICT WIDE	LIMITED SUPPLY 3 OF 3	09/16/2025
WEDEMEIER, SHANNON COLLEEN	DISTRICT WIDE	LIMITED SUPPLY 2 OF 3	09/16/2025
WELLS, MARY MELINDA	DISTRICT WIDE	DRUG & ALCOHOL COORDINATOR	09/01/2025
WELLS, MARY MELINDA	DISTRICT WIDE	LEADERSHIP STIPEND-FLIGHT TEAM	08/06/2025
WHALEN, JOSEPH PATRICK	CENTER FOR ADV PROF STUDIES	ADDL TEACHING RESPONSIBILITIES	08/06/2025
WHALEN, JOSEPH PATRICK	CENTER FOR ADV PROF STUDIES	CAPS BUSINESS PARTNERSHIP	08/06/2025
WHETZEL, AARON EDWARD	VIRTUAL ED	VIRTUAL EDUCATION-FALL	08/06/2025
WHITE, JOEL THOMAS	BLUE VALLEY SOUTHWEST HS	ADDL TEACHING PLAN-YEAR	08/06/2025
WIENS, NATHAN P	DISTRICT WIDE	NATIONAL BOARD CERTIFICATION	08/06/2025
WILCOX, BROOKE E	DISTRICT WIDE	LIMITED SUPPLY 3 OF 3	09/16/2025
WILES, ALLISON RAE	EDUCATIONAL SUPPORT CENTER	ADDL TEACHING RESPONSIBILITIES	08/06/2025
WILLIAMS, AARON TYLER	HARMONY MIDDLE SCHOOL	ASST COACH-TRACK	03/01/2026
WILLIAMS, SAVANNAH BAILEY	BLUE VALLEY HIGH SCHOOL	ADDL TEACHING SUPV-1ST SEM	09/29/2025
WILLIAMS, SAVANNAH BAILEY	DISTRICT WIDE	LIMITED SUPPLY 3 OF 3	09/16/2025
WILLIAMSON, ROBERT TYLER	DISTRICT WIDE	LIMITED SUPPLY 3 OF 3	09/16/2025
WILLSON, ALLISON LEE	AUBRY BEND MIDDLE SCHOOL	SUPERVISOR-1/2 HR LUNCHROOM	08/06/2025
WINGATE, EMERSON VENESSA	WOLF SPRINGS ELEMENTARY	ADDL TEACHING CI-YEAR	08/06/2025
WINTERS, EMILY ASPEN	BLUE VALLEY SOUTHWEST HS	COORDINATOR-GRADE LEVEL	08/06/2025
WINTON, JULIAN SHAWON	BLUE VALLEY NORTHWEST HS	ASST COACH-BOYS BASKETBALL	11/16/2025
WISEMAN, NICOLE ELIZABETH	DISTRICT WIDE	LIMITED SUPPLY 3 OF 3	09/16/2025
WISEMAN, TIM JEROME	BLUE VALLEY MIDDLE SCHOOL	SUPERVISOR-1/2 HR LUNCHROOM	08/06/2025
WOFFORD, C'AWNA CARLISA	BLUE VALLEY SOUTHWEST HS	SUPERVISOR-LUNCHROOM	08/06/2025
WOLTERS, CARLA JEAN	DISTRICT WIDE	LIMITED SUPPLY 3 OF 3	09/16/2025
WORTHINGTON, MARIA ANNE	DISTRICT WIDE	NATIONAL BOARD CERTIFICATION	08/06/2025
WOULFE, JULIE MARIE	BLUE VALLEY MIDDLE SCHOOL	SUPERVISOR-1/2 HR LUNCHROOM	08/06/2025
WRAY, BENJAMIN TIPTON	DISTRICT WIDE	NATIONAL BOARD CERTIFICATION	08/06/2025
WRIGHT, JEFFREY DONALD	AUBRY BEND MIDDLE SCHOOL	SUPERVISOR-1/2 HR LUNCHROOM	08/06/2025
YARNELL, JEFF E	BLUE VALLEY HIGH SCHOOL	DEPARTMENT CHAIR-PERFORM ARTS	08/06/2025
YOUNG, AMY S	DISTRICT WIDE	NATIONAL BOARD CERTIFICATION	08/06/2025
YOUNG, AMY S	PRAIRIE STAR MIDDLE SCHOOL	SUPERVISOR-1/2 HR LUNCHROOM	08/06/2025
YOUNG, DENISE LYNN	BLUE VALLEY WEST HIGH SCHOOL	ADDL TEACHING PLAN-YEAR	08/06/2025
ZAGORSKI, MOLLY ELIZABETH	LAKWOOD MIDDLE SCHOOL	SUPERVISOR-1/2 HR LUNCHROOM	08/06/2025



Human Resources Report to the Board of Education

Addendum

October 13, 2025

Administration recommends approval of the following actions:

ZHANG, HANXUAN
ZHANG, HU
ZIEGLER, KRISTIE M

DISTRICT WIDE
OVERLAND TRAIL MIDDLE SCHOOL
DISTRICT WIDE

LIMITED SUPPLY 2 OF 2
HEAD SPONSOR-SCIENCE OLYMPIAD
LIMITED SUPPLY 3 OF 3

09/16/2025
09/15/2025
09/16/2025



Human Resources Report to the Board of Education

October 13, 2025

Administration recommends approval of the following actions:

APPOINTMENTS

<u>Name</u>	<u>Location</u>	<u>Position</u>	<u>Effective</u>
BAILEY, MEGAN ELIZABETH	COTTONWOOD POINT ELEMENTARY	SPEECH LANGUAGE PATHOLOGIST	10/13/2025
BAILEY, MEGAN ELIZABETH	HEARTLAND ELEMENTARY	SPEECH LANGUAGE PATHOLOGIST	10/13/2025
BECKWITH, STEPHANIE JOY	HARMONY ELEMENTARY	SPEECH LANGUAGE PATHOLOGIST	01/05/2026
LAUNIUS, RACHEL CHRISTINE	BLUE VALLEY WEST HIGH SCHOOL	SPED TEACHER-INTENSIVE RESC	10/16/2025
PARKER BUCCI, RILEY	LEAWOOD ELEMENTARY	TEACHER-SPANISH	08/03/2026



Human Resources Report to the Board of Education

October 13, 2025

Administration recommends approval of the following actions:

RESIGNATIONS

<u>Name</u>	<u>Location</u>	<u>Position</u>	<u>Effective</u>
MORRIS, JESSICA ELIZABETH	HARMONY ELEMENTARY	SPEECH LANGUAGE PATHOLOGIST	09/26/2025
RICCARDI, KELLEY SUZANNE	BLUE VALLEY HIGH SCHOOL	SCHOOL NURSE	09/26/2025
WOODS, BRYAN DAVID	VALLEY PARK ELEMENTARY	SPED TEACHER-INTENSIVE RESC	09/25/2025



Human Resources Report to the Board of Education

October 13, 2025

Administration recommends approval of the following actions:

RETIREMENTS

<u>Name</u>	<u>Location</u>	<u>Position</u>	<u>Effective</u>
JILKA, THERESE MARIE	PLEASANT RIDGE MIDDLE SCHOOL	TEACHER-GRADE 8	05/22/2026

Blue Valley USD #229
Claims for 10/15/25

Vendor ID	Vendor Name	
066037	MCCOWNGORDON CONSTRUCTION LLC	3,467,294.92
074433	STRAUB CONSTRUCTION COMPANY IN	1,190,437.56
060686	CDW-GOVERNMENT INC	828,715.62
068762	PETERMANN STSA LLC	518,869.73
073757	US FOODS INC	517,979.09
057490	TRANE USA INC	511,564.40
069609	ALL POINT TRANSPORTATION LLC	231,322.58
066974	BCI MECHANICAL INC	193,751.81
068823	SUMMIT BEHAVIORAL SERVICES	191,184.40
068763	PETERMANN STS LLC	179,400.80
002757	MCCONNELL & ASSOCIATES CORP	165,436.70
071523	DELTA INNOVATIVE SERVICES INC.	158,707.53
074605	ZIPCO CONTRACTING INC	155,092.11
063258	STANBURY UNIFORMS INC	150,098.60
007946	HOLLIS & MILLER ARCHITECTS INC	97,897.03
068743	MC ELECTRIC INC.	93,532.75
072481	C & C PRODUCE	92,142.37
074235	UNIVERSAL CONSTRUCTION COMPANY	91,181.00
072542	PINNACLE STAFFING GROUP	90,686.27
067074	GOODWIN PRO TURF INC	87,012.00
063926	PLUMBING BY FISHER INC	81,838.52
070875	SPHERO INC	81,519.74
074500	AMERGIS HEALTHCARE STAFFING IN	80,717.49
050179	BSN SPORTS	79,334.69
073279	IMAGEQUEST INC	75,344.68
059725	COMMERCIAL AQUATIC SERVICES I	73,260.15
073910	SIGNATURE LANDSCAPE LLC	66,644.50
071483	HILAND DAIRY FOODS COMPANY LLC	55,972.08
073776	HUT AMERICAN GROUP LLC	53,249.50
067910	ENVISION TECHNOLOGY GROUP	50,288.00

Blue Valley USD #229
Claims for 10/15/25

Vendor ID	Vendor Name	
074798	JMF INTERNATIONAL GROUP INC	49,896.00
074807	HUWAR CONSTRUCTION AND DEVELOP	49,009.32
066408	DLR GROUP INC A KANSAS CORPORA	48,357.75
074237	SYNDEO STAFFING KANSAS CITY LL	47,321.33
064467	B&H PHOTO VIDEO	45,581.70
073401	SOLIANT STAFFING LLC	42,739.17
066280	REINDERS INC	42,714.02
061545	BENCHMARK INC	41,804.52
073938	CORPORATE CLEANING GROUP INC	41,643.00
064754	INTEGRATED CONTROLS LLC	41,060.53
074894	PROCARE THERAPY	39,328.95
063407	PAPER 101	34,828.60
064310	ACCUTEC SERVICES INC	33,859.00
073926	PROJECT LEAD THE WAY INC	32,766.80
066062	STAPLES CONTRACT & COMMERCIAL	31,503.28
073590	JOHNSON CONTROLS FIRE PROTECTI	30,583.48
065188	OMEGA DOOR & HARDWARE DIV OF M	30,503.75
050407	K & W UNDERGROUND INC	30,088.08
063937	INTERPRETING SOLUTIONS LLC	30,066.00
064307	CIRCADIA	28,581.00
073228	BRADY INDUSTRIES OF KANSAS LLC	28,532.00
019950	PUR-O-ZONE INC	27,604.35
074857	PERRY WEATHER INC	27,500.00
072434	WASTE MANAGEMENT OF KANSAS INC	25,239.83
058696	PIONEER ATHLETICS	23,316.41
071832	BEHAVIORAL HEALTH ALLIES	22,925.50
010225	GRAINGER	22,719.33
074787	CAPITAL AGGREGATES	21,360.32
000238	KENTON BROTHERS INC	19,865.68
001964	ANIXTER INC - KANSAS CITY	19,438.00

**Blue Valley USD #229
Claims for 10/15/25**

Vendor ID	Vendor Name	
063632	MAXIM HEALTHCARE SERVICES INC	18,630.28
074182	DR DEBS CENTER FOR CHILD AND F	18,500.00
074573	A&E TREE LLC	18,400.00
065665	KRUGER TECHNOLOGIES INC	17,778.75
074927	BRIGHTHOUSE ACADEMY LLC, THE	17,619.15
000300	KELLER FIRE & SAFETY INC	17,284.95
002540	STANION WHOLESALE ELECTRIC CO	17,169.39
074836	OLATHE FLEET SOLUTIONS LLC	17,068.99
072705	STANGER INDUSTRIES INC	16,321.75
057976	COLEMAN EQUIPMENT INC	16,306.73
073448	SCHOOL SPECIALTY LLC	16,271.42
059562	HONEY WAGON	16,238.00
067784	FAVORITE HEALTHCARE STAFFING L	15,621.73
069960	SUPPLEMENTAL HEALTH CARE SERVI	14,475.18
073900	AD TRENDS ADVERTISING INC	14,447.73
072075	POWERSCHOOL GROUP LLC	13,990.19
074561	WIL FISCHER CO OF KS	13,964.66
067703	SCHOLASTIC CLASSROOM MAGAZINES	13,333.49
074476	DAIKIN TMI LLC	13,270.58
051394	OVERHEAD DOOR	13,205.11
066010	ROMA BAKERY	13,202.07
073305	DILIGENT CORPORATION	12,600.00
001123	LAKEMARY CENTER INC	12,360.00
066442	VIRCO INC	12,021.30
050850	XEROX CORPORATION	11,579.56
066424	SITEONE LANDSCAPE SUPPLY LLC	11,540.06
070386	PRINCETON REVIEW, THE	11,484.00
066328	OLSSON INC	11,292.90
072802	SOURCES OF STRENGTH INC	11,250.00
069292	BUILDING CONTROLS & INTEGRATIO	11,211.12

Blue Valley USD #229
Claims for 10/15/25

Vendor ID	Vendor Name	
054008	PAUL H BROOKES PUBLISHING CO I	10,823.96
074895	BEDFORD NELSON LLC	10,800.00
074856	GUY MASTERS	10,800.00
057395	FRY-WAGNER MOVING & STORAGE	10,796.90
000341	J W PEPPER	10,485.48
073777	MINIPCR BIO	10,180.00
X03363	DALTON, GREGORY N	10,000.00
059724	WEATHER OR NOT INC	9,916.00
074567	HELM SERVICE	9,837.25
072894	REED JEEP CHRYSLER DODGE RAM	9,529.67
074892	IML SECURITY SUPPLY	9,350.68
073746	FOLLETT CONTENT SOLUTIONS LLC	9,295.11
074918	CHARLES MACHINE WORKS INC, THE	9,047.12
063508	BRAINPOP	9,000.00
000159	ABBEY SIMONS CO	8,958.00
074587	PEPSICO BEVERAGE SALES LLC	8,935.20
074555	CERTAPRO PAINTERS OF SHAWNEE M	8,785.20
074620	EDYNAMIC LP	8,295.00
073167	FREEDOM INTERIOR SOLUTIONS LLC	7,768.88
071843	FOLEY EQUIPMENT COMPANY	7,686.23
066551	STAR SIGNS LLC	7,580.00
071558	SYNETIC TECHNOLOGIES	7,393.00
066856	HERITAGE-CRYSTAL CLEAN LLC	7,370.00
071677	PUBLIC CONSULTING GROUP INC	7,346.76
072574	TEHCYCLE SOLUTIONS LLC	7,338.60
074697	JESSICA MINAHAN LLC	7,274.56
006972	BLICK ART MATERIALS LLC	7,140.69
X03415	VISAUDIO DESIGNS LLC	7,000.00
072611	SDC PUBLICATIONS	6,780.00
073287	K12 CONSULTING AND THERAPY SER	6,768.75

Blue Valley USD #229
Claims for 10/15/25

Vendor ID	Vendor Name	
063829	THOMAS MCGEE GROUP	6,628.00
054191	MEYER MUSIC COMPANY	6,607.98
056352	VALIDITY SCREENING SOLUTIONS	6,606.80
061475	CRAIG HOMECARE	6,595.68
002303	BLACKMORE & GLUNT INC	6,563.03
069524	USIC LOCATING SERVICES INC	6,458.67
073768	BRIGHTSTAR CARE OVERLAND PARK/	6,420.00
073613	MEDICALESHP INC	6,356.04
074912	STEPHANIE HIBLER	6,272.50
068708	GLOBAL EQUIPMENT COMPANY	6,228.89
074141	KC ARCHITECTS LLC	6,185.50
074138	ATHCO ACQUISITION CORP	6,150.00
073178	HON COMPANY	5,908.97
073798	FULLY PROMOTED	5,904.00
074893	AIRBORNE MECHANICAL SERVICES L	5,885.65
063492	SELECT MARKETING & DISTRIBUTIN	5,863.77
056723	DISCOVERY EDUCATION	5,801.99
059064	BROSKI FENCE CO LLC	5,796.00
074198	WESTCOM WIRELESS INC	5,615.33
071154	PROFESSIONAL COMPONENTS LTD	5,589.09
074407	SOCIAL WORK PRN INC	5,471.82
062508	CONFERENCE TECHNOLOGIES INC	5,409.84
073665	PITSCO EDUCATION LLC	5,262.19
050394	CROFT TRAILER SUPPLY INC	5,187.98
065862	KANSAS BUREAU OF INVESTIGATION	5,187.00
004350	CAROLINA BIOLOGICAL SUPPLY CO	5,154.01
072824	MONOPRICE INC	5,105.62
069089	WALDINGER CORPORATION, THE	4,952.18
052728	DELL COMPUTER CORP	4,937.52
061361	UNITED REFRIGERATION INC	4,840.07

Blue Valley USD #229
Claims for 10/15/25

Vendor ID	Vendor Name	
051766	COMMITTEE FOR CHILDREN	4,830.00
071527	GRIMCO INC	4,765.26
002035	BEARING HEADQUARTERS COMPANY	4,754.17
062393	BYERS GLASS AND MIRROR INC	4,634.90
074933	JOHNSON STORAGE & MOVING CO HO	4,586.00
054793	CENTAR INDUSTRIES INC	4,569.75
056760	LIVERY STABLE AUTOMOTIVE INC,	4,488.14
072549	MARKETING TULES	4,383.45
072728	HOBART SERVICE	4,346.71
055818	AMERICAN TIME & SIGNAL CO	4,214.03
004775	CHARLES D JONES CO INC	4,192.50
056954	ADORAMA INC	4,154.66
055728	POLAR ELECTRO INC	4,150.00
074450	MILLER, PAT	4,000.00
062677	IXL LEARNING INC	3,975.00
073330	KANSAS CITY WINNELSON	3,909.33
071705	ESGI LLC	3,885.00
061757	AGILIX SOLUTIONS LLC	3,822.38
067938	PERFORMANCE TINT LLC	3,671.50
073536	FAST SIGNS-90601	3,644.10
072726	NANOPAC INC	3,602.00
057703	ARROW STAGE LINE	3,590.00
073720	SMOOTHIE KING	3,566.55
070872	UNIVERSITY OF KANSAS HOSPITAL	3,480.75
073259	CONTROL DEPOT INC	3,441.72
069558	ELECTRONIC SYSTEMS INTEGRATION	3,355.60
070004	OLATHE STRIPING	3,275.00
072997	HD SUPPLY INC	3,265.63
071179	LINDE GAS & EQUIPMENT INC	3,242.28
073127	UNITED STATES AWARDS INC	3,240.96

Blue Valley USD #229
Claims for 10/15/25

Vendor ID	Vendor Name	
061148	JOHNSON COUNTY COMMUNITY COLLE	3,220.00
072889	BORDER STATES ELECTRIC SUPPLY	3,121.59
074929	INTERNATIONAL SPORTS TURF RESE	3,120.00
066675	GOPHER SPORT	3,060.59
074264	COOPERATING SCHOOL DISTRICTS O	3,000.00
072050	INSTRUCTURE INC	3,000.00
067628	GUITAR CENTER	2,931.62
072536	BRINGING THERAPY HOME LLC	2,925.00
073759	AMERICAN PEST MANAGEMENT	2,864.00
064042	SCHOOL OUTFITTERS	2,855.23
074818	JADE ALARM CO	2,810.00
065919	MEDCO SUPPLY	2,778.03
073549	PRUSA RESEARCH A.S.	2,637.96
068416	AMBROSE PACKAGING INC	2,616.37
074700	SWEETWATER SOUND LLC	2,604.87
074479	WALSH DOOR & SECURITY	2,584.64
013450	KANSAS CITY AUDIO VISUAL INC	2,556.00
066562	CINTAS CORPORATION NO 2	2,488.29
071015	TRESONA MULTIMEDIA LLC	2,480.00
027200	WEST MUSIC COMPANY INC	2,464.95
067072	GENERAL PARTS LLC	2,462.79
003000	BOUND TO STAY BOUND BOOKS INC	2,435.07
074248	MMW INSTALLATION LLC	2,400.00
000915	BLUE VALLEY FOOD SERVICE DEPT	2,337.80
071891	KAPITAN BAND INSTRUMENT REPAIR	2,315.00
070193	PROPIO LANGUAGE SERVICES	2,304.25
073914	PICKUP PATROL LLC	2,302.83
074886	CITY WIDE FACILITY SOLUTIONS -	2,285.50
069691	JOHNSON COUNTY EQUIPMENT & PAR	2,258.30
071792	CORNERSTONES OF CARE	2,250.00

Blue Valley USD #229
Claims for 10/15/25

Vendor ID	Vendor Name	
074961	NO LIMITS DANCE & ACROBATIC TR	2,215.82
073790	PARTS TOWN LLC	2,214.71
062501	ABLE HANDS INTERPRETING SERVIC	2,163.85
070096	KANSAS CARENOW URGENT CARE LLC	2,150.00
062414	BIO RAD LABORATORIES INC	2,120.10
071429	GPA	2,095.44
074851	CESO COMMUNICATIONS LLC	2,000.00
074932	LEADING EDGE GROUP LLC	1,950.00
009585	GALE GROUP INC, THE	1,944.01
001465	BRACKER'S GOOD EARTH CLAYS INC	1,882.39
057213	RIDDELL ALL AMERICAN	1,864.95
074919	NILES HOME FOR CHILDREN	1,800.00
067197	THE AMERICAN BOTTLING CO INC	1,771.31
012198	CITY OF OVERLAND PARK	1,723.97
066939	BLUE VALLEY TRACTOR	1,697.62
074763	FOCUS CAMERA LLC	1,661.00
057798	COLLEGE BOARD, THE	1,600.00
072577	HANGSAFE HOOKS	1,598.15
072243	BLACK DOG BASS WORKS	1,560.00
073650	FIX A FIELD LLC	1,500.00
X03293	WILLIAMS, COLE MORGAN	1,500.00
064211	ULINE INC	1,465.19
070100	MULTIVISTA	1,420.00
074944	BOUND	1,418.00
071336	AMERICAN SOLUTIONS FOR BUSINES	1,409.56
072697	LOWES COMPANIES INC	1,409.14
001286	JOHNSON CONTROLS INC	1,394.59
072940	DEAN'S TROPHIES	1,344.99
074196	CCG SAFETY GEAR LLC	1,338.00
066438	BOB D CAMPBELL AND COMPANY	1,300.00

Blue Valley USD #229
Claims for 10/15/25

Vendor ID	Vendor Name	
X03299	TEEL, BRYSON	1,300.00
065866	LAKESHORE LEARNING MATERIALS	1,294.97
072723	UNIFIED SCHOOL DISTRICT 500	1,294.62
063855	MCQUEENY GROUP INC	1,294.43
062814	DECKER INC	1,284.39
065417	ROASTERIE INC, THE	1,279.40
064653	95 PERCENT GROUP INC	1,265.00
072017	BUILDING CONTROLS AND SERVICES	1,237.70
073570	KRONOS SAASHR INC	1,231.29
074683	SOUND SUCCESS LLC	1,125.00
066654	MACKIN BOOK COMPANY	1,077.98
074294	BLOOMSBURY PUBLISHING INC	1,070.18
060071	OFFICE DEPOT (BUSINESS SERVICE	1,032.94
064530	LEXIA LEARNING SYSTEMS --USE 0	1,012.00
002019	KANSAS ASSOCIATION OF SCHOOL B	1,000.00
073960	WEBER TECHNOLOGY CONSULTANTS L	968.70
070888	POP CREATIVE DESIGN	935.00
056910	FASTENAL COMPANY	931.06
073781	HOWIES ATHLETIC TAPE	928.46
057123	ZIMMERMAN CONSTRUCTION CO INC	908.74
074679	OLD SCHOOL HORNS	848.28
072128	SPORTDECALS	842.88
072258	RUSHORDERTEES	832.19
074219	EPS OPERATIONS LLC	829.50
074372	CURRICULUM ASSOCIATES LLC	805.51
074899	L&W SUPPLY CORPORATION	803.88
072182	ASSISTED STUDENT TRANSPORTATIO	783.17
059030	SPENCER FANE BRITT AND BROWNE	777.00
070209	BERGERON HEALTH CARE	760.61
019790	PRO ED	759.00

Blue Valley USD #229
Claims for 10/15/25

Vendor ID	Vendor Name	
073927	BOUNDLESS NETWORK INC	758.68
012146	INDUSTRIAL SALES COMPANY	729.72
006800	DEMCO INC	726.44
071021	KIMBALL MIDWEST	724.57
067781	KANSAS ONE CALL SYSTEM INC	719.53
066659	AVB PRESS	692.93
072308	OTICON MEDICAL	639.99
059845	LIBERTY HARDWOODS INC	633.40
071856	WESTLAKE HARDWARE INC	623.69
001591	SUPER DUPER PUBLICATIONS	619.55
061797	SMITTY'S LAWN AND GARDEN EQUIP	608.96
070089	FITZPATRICK GOLF SHOP LLC	600.00
073089	CONTINUED.COM LLC	594.00
073519	CET COLOR INC	581.73
068684	SPRAYER SPECIALTIES	574.01
064481	UNITED RENTALS (NORTH AMERICA)	565.55
074737	DONNA & VIOLA'S SHIRTS ETC LLC	558.00
054943	AMERICAN PRINTING HOUSE FOR TH	551.65
067585	COMFORT PRODUCTS DISTRIBUTING	531.40
059516	KAW ROOFING AND SHEET METAL IN	525.00
074926	IPEVO INC	524.80
001808	JOHNSTONE SUPPLY	519.60
008530	ELECTRONIC CONTRACTING COMPANY	505.00
064580	STYERS EQUIPMENT COMPANY	504.25
074942	THOMAS, ASHTON	500.00
065624	ABSOLUTE AWARDS INC	460.00
073468	CCC SERVICES LLC	450.00
073209	LITERACY RESOURCES LLC	445.00
073712	PRC SALTILLO	429.00
073825	J & J SCREEN CO	418.00

Blue Valley USD #229
Claims for 10/15/25

Vendor ID	Vendor Name	
X03056	COKER, KEVIN L	400.00
072458	KANSAS STATE SCHOOL FOR BLIND	400.00
074925	MKM CREATIONS	400.00
066750	SMALLWOOD LOCK SUPPLY INC	380.28
070349	EGENCIA LLC	375.00
073773	E EDWARDS WORK WEAR	364.45
022460	ADA BADMINTON & TENNIS	362.94
013950	KAPLAN EARLY LEARNING CO	362.19
052214	LEXIA LEARNING SYSTEMS LLC	354.00
072820	NASCO	334.89
060795	LEARNING RESOURCES INC	317.96
066533	AMBUTECH	312.37
065800	KA-COMM INC	300.00
068946	CONCEPT PRODUCTS	278.80
074612	HEDRICK MUSIC INC	278.69
074745	ROMANAZZI, MICHAEL	275.00
073879	SOUTH WESTERN COMMUNICATIONS I	275.00
070618	PERIPOLE	272.39
050266	FAST SIGNS	265.88
073629	ID WHOLESALER IDW LLC	257.17
074657	ALL SURFACES INC	252.46
074963	ROTARY CLUB OF LEAWOOD KS CHAR	250.00
002542	SUBURBAN LAWN AND GARDEN	249.95
066726	KONE INC	243.72
057906	O'REILLY AUTO PARTS	207.88
073591	OXFORD COMPUTER GROUP WORLDWID	200.00
073846	SEGURA STUDIOS LLC	200.00
074668	THOU MAYEST LLC	195.00
074777	MG MUSIC REPAIR LLC	190.00
067827	LAMINATION EQUIPMENT & SUPPLY	186.40

Blue Valley USD #229
Claims for 10/15/25

Vendor ID	Vendor Name	
074256	MAXON AMERICA INC	177.00
073621	MARTIN TECHNICAL SERVICE LLC	175.00
054274	ELECTRONICS SUPPLY CO INC	169.50
068850	REJIS COMMISSION	169.24
074040	BYRDSEED LLC	159.00
072521	3D UNIVERSE	156.00
055781	MAXI AIDS	156.00
073157	UNIFIRST CORPORATION	153.15
062334	HARPERS FABRIC & QUILT CO	145.00
058138	PRICE CHOPPER - QUEENS	133.06
056351	CARROLL SEATING COMPANY	127.37
054011	SEE MORE SIGNS MFG INC	125.00
059421	SCHOOL NURSE SUPPLY INC	121.39
053359	COCHLEAR AMERICAS	119.00
074530	KANG, JIHYUN	118.75
074511	ANCESCHI ANTUNES DA COSTA, NAT	112.50
073935	DELTAMATH SOLUTIONS INC	110.00
066987	DISCOUNT SCHOOL SUPPLY	105.43
074756	PHYLLIS J JOHNSEN	105.00
074910	DE LIMA SANTOS, ALINE ROCHA	100.00
073501	TURNERS CONSUMER APPLIANCE SER	99.95
064100	THE RED FORCE FIRE AND SECURIT	97.15
074688	TOWER GARDEN LLC	96.00
050231	REALLY GOOD STUFF INC	95.01
074184	VENTRIS LEARNING LLC	90.00
072504	VERITIV OPERATING COMPANY	89.00
074832	BARBOSA DE ROUSSEAU, FABIO	87.50
073239	KANSAS HOSA	82.46
000711	LIBRARY STORE INC	82.15
067080	HARRISON MACHINE SHOP & WELDIN	80.00

Blue Valley USD #229
Claims for 10/15/25

Vendor ID	Vendor Name	
071660	PALEN MUSIC CENTER INC	76.93
057855	REALITYWORKS INC	73.00
073161	BJOREM SPEECH PUBLICATIONS LLC	65.95
021700	SCHOOL HEALTH CORPORATION	62.56
073550	KAMETA, MARCIE	62.50
055746	LUCK'S MUSIC LIBRARY	56.08
061098	TEACHERS DISCOVERY	52.84
009030	FLINN SCIENTIFIC INC	48.62
062961	SHIFFLER EQUIPMENT SALES INC	40.50
074272	WEBSTER, SVETLANA	12.50
070282	GT DISTRIBUTORS INC	10.00
	GRAND TOTAL	11,907,672.25

Blue Valley USD #229
Disbursements for September 2025

Vendor ID	Vendor Name	
ACH	STATE OF KS - BOND/INTEREST PMT	47,905,943.77
ACH	INTERNAL REVENUE SERVICE	4,132,683.71
ACH	BLUE CROSS BLUE SHIELD OF KC	3,197,865.17
ACH	KPERS	1,053,872.15
ACH	EVERGY	985,144.72
ACH	KANSAS DEPARTMENT OF REVENUE	829,642.88
ACH	BVRC - AdVALOREM	744,524.82
ACH	TRANSAMERICA/DIVERSIFIED INVESTMENT	377,229.77
ACH	COMMERCE - PCARDS	365,494.22
ACH	H S A - U M B	154,549.15
ACH	DELTA DENTAL	124,659.28
061931	CARTER ENERGY CORP	87,336.51
ACH	WATERONE WEBPAY	75,567.20
ACH	ARBITERPAY LLC	75,000.00
ACH	TriSTAR - FLEX - MED/DEP REIMBURSEMENT	73,219.74
ACH	THE STANDARD INS - STD/LTD/SUP LIFE	71,365.84
066408	DLR GROUP INC A KANSAS CORPORA	48,357.75
ACH	THOMAS McGEE - WK COMP	42,424.00
055540	BLUE VALLEY EDUCATIONAL FOUNDA	35,095.56
073862	IMAGINE LEARNING LLC	27,500.00
ACH	SURENCY - VISION INSURANCE	24,968.48
074875	AT&T ENTERPRISES LLC	24,152.14
ACH	KPERS - WAR	24,150.40
ACH	BVNEA	22,153.24
073929	WOODRIVER ENERGY LLC	19,113.92
ACH	THE STANDARD INS - AI/HI/CI	15,430.45
ACH	STATE OF KS - SALES TAX	15,361.16
070801	BURDISS LETTER SHOP SERVICES C	13,000.00
ACH	THOMAS McGEE - P&C	10,400.75
074636	N2 LEARNING, LC	10,000.00

**Blue Valley USD #229
Disbursements for September 2025**

Vendor ID	Vendor Name	
ACH	KCPAY - KANSAS CHILD SUPPORT	6,910.77
ACH	BVW PTO	6,773.46
ACH	ALLSTATE - IDENTITY INSURANCE	6,694.16
ACH	KANSAS GAS SERVICE	6,521.58
ACH	BVNW BOOSTER CLUB	5,786.37
ACH	BVH PTO	4,755.52
ACH	ARAG - LEGAL SERVICE BENEFIT	4,394.52
063040	ATMOS ENERGY	4,271.70
ACH	BVEF	3,811.50
069133	VERIZON WIRELESS	3,775.66
013910	KSHSAA	3,578.00
ACH	FSPC CHILDSUPPORT - MISSOURI	2,555.00
ACH	EXECUTIVE LIFE SOLUTIONS - FOCUS 10	2,421.68
ACH	BVSW PTO	2,382.62
ACH	HES PTO	2,275.65
071385	MIDLAND PAPER	2,174.16
058136	GRIFFIN, WILLIAM H	2,100.00
068532	INFORMATION NETWORK OF KANSAS	1,909.31
ACH	CITY OF KCMO - EARNINGS TAX	1,882.84
054959	BLUE VALLEY NORTHWEST HIGH	1,868.29
ACH	SRE PTO	1,838.02
ACH	LES PTO	1,546.27
ACH	WSE PTO	1,531.69
ACH	TriSTAR SYSTEMS - ADMIN FEE	1,507.65
074876	UNIVERSAL CHEERLEADERS ASSOCIA	1,455.00
ACH	HMS PTO	1,366.36
071089	BESSINE WALTERBACH LLP	1,358.53
ACH	LMS PTO	1,335.24
062704	BLUE VALLEY WEST	1,311.56
067797	COMMERCIAL LAW GROUP PA	1,306.72

Blue Valley USD #229
Disbursements for September 2025

Vendor ID	Vendor Name	
073795	JOHNSON, JACQUELINE	1,285.05
068414	LIFT TRUCK SALES	1,275.76
ACH	MOR PTO	1,215.62
074548	BEAUTIFUL MUSIC VIOLIN SHOP LL	1,204.30
000202	BLUE VALLEY NORTH HIGH SCHOOL	1,178.49
BVSW	BLUE VALLEY SOUTHWEST HIGH SCH	1,170.38
002730	BLUE VALLEY HIGH SCHOOL	1,160.87
053879	WICHITA STATE UNIVERSITY	1,150.00
ACH	PSM PTO	1,114.48
072662	W H GRIFFIN TRUSTEE	1,042.50
ACH	AGE PTO	1,021.12
P13928	MARKOWICZ, ERIC	1,009.14
068487	BVM PTO	972.50
000915	BLUE VALLEY FOOD SERVICE DEPT	935.76
ACH	OTM PTO	865.52
ACH	OMS PTO	855.80
067700	LAWRENCE FREE STATE HIGH SCHOO	840.00
072383	FOUNDATION BUILDING MATERIALS	838.66
ACH	CITY OF OLATHE - UTILITIES	831.14
ACH	ABM PTO	826.62
ACH	IVE PTO	826.62
ACH	OTE PTO	758.55
066713	BERMAN & RABIN	746.94
074869	VRC COMPANIES LLC	706.81
021132	RITTERMEYER, JACOB WARING	702.52
067028	EAGLES LANDING GOLF COURSE	660.00
ACH	EXPERTPAY - CA CHILD SUPPORT	656.00
068861	OLATHE NORTH	620.00
066698	TIMBER CREEK ELEMENTARY - PETT	564.73
002502	BURGIN, PAUL A	559.51

Blue Valley USD #229
Disbursements for September 2025

Vendor ID	Vendor Name	
019568	VEDDER, ROSS DANIEL	549.64
070183	COUNTRY CLUB OF LEAWOOD	540.00
071997	INNOVATIVE CHOREOGRAPHY LLC	540.00
063220	BUTLER & ASSOCIATES PA	504.56
074877	VARSITY SPIRIT FASHIONS & SUPP	500.00
074956	VARSITY SPIRIT LLC	500.00
067599	BVSW - ONLINE FEES	475.30
068525	BLUE SPRINGS R-IV SCHOOL DISTR	450.00
074578	FRIENDS OF THE GOLDEN REGIMENT	450.00
016683	MARTIN, ALAN PATRICK	446.60
014667	SPENCER, BRICE MORGAN	420.70
074183	BFLY OPERATIONS INC	420.00
ACH	LKE PTO	413.31
ACH	OHE PTO	413.31
069149	TOPEKA SEAMAN HIGH SCHOOL	390.00
000630	MULLEN, STACIE ANN	389.93
073448	SCHOOL SPECIALTY LLC	380.78
073239	KANSAS HOSA	375.00
071266	KANSAS BANDMASTERS ASSOCIATION	350.00
074930	OLATHE NORTHWEST HIGH SCHOOL R	350.00
017314	HOTZEL, AARON JAY	335.23
011305	DREYER, MIKAYLA WEBER	328.86
013090	BARRETT, RYAN C	316.89
015618	RICHARDS, MICHAEL E	315.00
ACH	BRE PTO	311.20
007963	GILLAM, JASON T	311.00
015188	BLAKELY, JOANN	308.84
067702	ST THOMAS AQUINAS HIGH SCHOOL	300.00
063013	CULLIGAN OF GREATER KANSAS CIT	300.00
004131	BROWN, MARY KATHERINE	297.44

Blue Valley USD #229
Disbursements for September 2025

Vendor ID	Vendor Name	
014458	BOX, BRIAN SAMUEL	292.52
021499	MICHAELS, EVAN	292.48
ACH	HRT PTO	291.75
022219	SHORTES, NOLAN RYAN	277.20
019923	WRIGHT, JILL KATHRYN	273.77
002044	NORRIS, JUSTIN M	272.41
065689	NICKLAUS GOLF CLUB LP AT LIONS	270.00
ACH	HLC PTA	262.57
065931	PITNEY BOWES BANK INC (RESERVE	258.87
074935	WONER REEDER & GIRARD PA	257.19
019681	BENSCHIEDT, LAURA LOUISE	252.00
018921	LONERGAN, MARY COLLEEN	251.09
073372	GREATER KANSAS CITY CROSS COUN	250.00
P13913	MEZA, WILLIAM	245.00
022317	MOORE, JOSHUA D'ANGELO	240.87
068822	WASHBURN RURAL HIGH	240.00
P13925	SCHOPPER, JESSICA	238.65
013767	DECANIO, ANNETTE	232.00
022810	FERNANDEZ ALARCON, EDUARDO JOS	232.00
018698	FOWLER, SUSAN E	232.00
008944	MITCHUM, KATIE A	232.00
074642	FIRST IN MISSOURI	225.00
067226	LEES SUMMIT SCHOOL DISTRICT	225.00
023005	RICHCREEK, MARIAH CALYN	220.68
064418	BVH ONLINE FEES	220.50
008910	DELAHUNT, COLM	218.33
P13924	LYAN, DAVID	215.00
P13284	KO, ANGELA	210.00
003424	FREUND, RODNEY H	205.03
002426	LOVEALL, MARLA ANN	202.02

Blue Valley USD #229
Disbursements for September 2025

Vendor ID	Vendor Name	
066301	RAYMORE PECULIAR SCHOOL DISTRI	200.00
015833	MITCHELL, CHANIE DAWN	195.16
ACH	LKM PTO	194.50
022889	LEWIS, MARY KATHLEEN	191.38
018756	BELL, CHRISTOFER CHARLES	187.50
015078	CORSER, KENT CHARLES	187.50
002403	MEYERS, MICHAEL J	187.50
003359	GIESEKE, NANCY ANNETTE	182.84
P13478	DEGNAN, ANGELA	182.00
050228	JOHNSON COUNTY PARKS & RECREAT	180.00
013477	SKEENS, WILLIAM ALLEN	176.40
018877	QUEZADA-REYES, ABRAHAM	176.05
065310	ST JAMES ACADEMY	175.00
015753	JOHNSON, TOMMY L	173.04
022189	HOGAN, NICOLE K	169.89
019387	GILLIAN, HILARIE GRACE	169.19
008128	RAMSTAD, DEREK JOHN	167.23
022041	TAYLOR, MARTHA L	166.88
022105	TODD, JEREMY	166.00
021439	LIND, LISA J	163.10
001156	PETERMAN, ANDREA S	162.89
023022	STAINES, RYAN MICHAEL	162.61
022118	BLACKWELL, SHELLEY L	159.92
012003	HAGSTROM, HEATHER MARIE	159.81
022697	BILLINGER, BRANDON JAMES	157.78
013512	FLUIS, JARED C	154.28
016043	DILLAVOU, MEGAN SUZANNE	152.88
068813	BALDWIN CITY USD 348	150.00
068838	LAWRENCE HIGH SCHOOL	150.00
068590	LOUISBURG HIGH SCHOOL	150.00

Blue Valley USD #229
Disbursements for September 2025

Vendor ID	Vendor Name	
013457	WESSEL, ADAM JOSEPH	148.00
002652	ROBERTS, SCOTT ALAN	146.00
009022	WELLS, MARY MELINDA	146.00
018320	OBOLD-GEARY, REBECCA RUTH	145.60
010012	DEFOREST, ASHLEY ROSE	140.07
068820	TURNER USD 202	140.00
ACH	CPE PTO	138.09
019689	MCLAUGHLIN, TANNER D	137.76
018234	KRIEGSHAUSER, LAURA A	136.85
020392	CLARK, JACOB DAVID	136.29
014697	HURT, COURTNEY CONNOLLY	136.01
014324	MUNINGER, ALEX ANDREW	135.00
010055	VAIL, KIMBERLY SHANNON	135.00
020523	RAHMEIER, KELLY D	134.68
013620	SCOTTEN, DONNA G	134.12
014675	LEAWOOD ELEMENTARY SCHOOL	133.66
018620	MUSAU, ROSHONDA MARIE	133.14
074924	CLERK OF THE COURT	132.98
002331	SUMNER, MONICA RAE	130.13
051031	OVERLAND TRAIL ELEMENTARY	129.97
016555	BERAK, COLETT PEARL	129.85
000496	PUNSWICK, ERIC J	129.50
068873	NATIONAL ASSOCIATION FOR MUSIC	129.00
001807	JENSEN, TERRY U	128.80
005566	JONES, JENNIFER L	126.91
023088	MASON, KATHERINE IRENE	125.58
068611	BASEHOR LINWOOD USD 458	125.00
070240	OLATHE SOUTH HIGH SCHOOL	125.00
020300	BURFORD, CLAUDIA MAJA	122.36
010169	CARNEY, REBEKAH LEEANN	122.20

Blue Valley USD #229
Disbursements for September 2025

Vendor ID	Vendor Name	
017801	GILLILAND, WENDY LYNN	118.72
071179	LINDE GAS & EQUIPMENT INC	117.45
006761	JIROVEC, DONNA MARIE	117.39
022757	KURE, NICHOLAS ANTHONY	117.11
017882	MCDONALD, CHERYL ANN	116.97
011340	MARTINEK, MICHELE LYNN	115.71
018397	VISCONTI, KIMBERLY DAWN	113.33
019698	WALKER, AUBRIE NORINE	111.86
014872	RONDON, MARY FRANCES	109.83
015006	VENABLE, KRISTIN J	109.12
021384	SCHEUFLER, ASHLEY LYNN	109.06
019654	MONTGOMERY, MORGAN LYNN	108.92
018868	CHAVEZ, EMMA CAITLYN	108.50
003184	PETERS, NICOLE LEIGH	107.66
003224	DOLLINS, SARAH RENEE	107.03
016460	MERINO, SONJA LYNN	104.93
016717	KOCHANOWSKI, TRICIA MARIE	101.71
014620	BURTON, STUART LYLE	100.80
017500	SVILARICH, STEPHANIE LINN	100.17
022327	GILL, MONICA	99.82
054829	STERICYCLE	98.40
055028	NATIONAL SPEECH AND DEBATE ASS	98.00
020070	CHILDERS, BRIANNA LAUREN	96.00
021618	EISSOUH, ANA	95.76
005069	VEST, ANGELA K	95.41
020528	WASKO, STEVEN M	94.43
023090	HOOVER, REBA LOUISE	89.11
012073	ELY, MELISSA ANN	88.90
005355	RABBITT, JOCELYN RENEE	88.55
006091	HENZLIK, KIRSTEN LEE	88.06

Blue Valley USD #229
Disbursements for September 2025

Vendor ID	Vendor Name	
010709	CONRAD, LAUREL MARIE	87.85
015353	MCDAVID, KATHLEEN HELEN	87.01
021587	CONNOLLY, CAITLYN MARIE	86.59
014261	TURRENTINE, MARK WILLIAM	85.96
021412	LYCHE, ABIGAIL G	84.00
013336	YOUNGER, KRISTEN M	83.30
P13927	MARTINEZ, SARITA	83.00
022250	WEDEMEIER, SHANNON COLLEEN	82.60
006735	CUMBERLAND, SIDNEY	82.53
000493	O'CONNOR, JUDITH ANN	82.53
015386	LOOMIS, STEVEN TODD	82.46
004119	FEAR, AMY ELISSA	82.25
020236	DE LEIRIS, SARAH CATHERINE	80.99
016447	SLICKMAN, KASSIDY ALAINE	80.64
016453	JIRAK, SHARON KAY	79.38
017425	MONSON, ANDREW JAMES	79.17
010685	VOOR VART, LEANN RENAE	77.21
001802	SCAVUZZO, AMY	76.37
068399	SHAWNEE MISSION EAST HIGH SCHO	75.00
003977	DRUMMOND, MELISSA A	73.71
021900	HAYDEN, MERON	73.71
020151	NOWLIN, ALAYNA ELIZABETH	73.54
064420	BVN ONLINE FEES	73.50
064421	BVNW ONLINE FEES	73.50
016433	WILES, ALLISON RAE	73.15
022214	KIRCH, MADISON DAWN	73.00
018340	HERNANDEZ, GISELLE	72.45
023264	PEREZ AGUIAR, JOEL D	71.89
022964	POESCHL, SARAH J	71.68
021525	BELLANTE, MELISSA MAE	71.26

Blue Valley USD #229
Disbursements for September 2025

Vendor ID	Vendor Name	
012006	JAMES, JEAN CAITLIN	69.79
018419	GRAHAM, THERESA	69.09
016476	GILLESPIE, MELISSA LYNNE	68.74
015730	O'DONNELL, MOLLIE ANNE	68.39
022954	RYAN, JAMES PATRICK	67.55
073855	TCE ONLINE FEES	66.83
002432	VARNER, TERESA L	64.19
014897	HAWKS, BRANDON T	63.63
006874	DILLAVOU, JENNIFER	62.51
011286	BOLTON, CRISTY YVONNE	62.37
017991	HARRELSON, CATHERINE RUTH	62.16
002151	HELLER, PAMELA J	61.46
022351	ROTH, BLAKE ANTHONY	61.39
005097	RITTER, CANDACE J	61.25
023219	FOSTER, ALEXIS ANN	60.62
020186	CUEVAS, MONICA	60.41
063867	KSDE	60.00
018434	BEALS, WILFORD E	59.50
022184	RELIFORD, DARRYL W	59.22
021826	HALL, JOSHUA ROBERT	59.15
003101	SCHMOLLINGER, MAX W	58.80
022750	HENDERSON, KELLY RYNA	57.96
016543	WATERS, EMILY AUTUMN	57.96
017676	DERRINGER, DEBORAH ANN	57.54
020181	HARRISON, BETHANY LYNN	56.77
003358	STRAIN, BENJAMIN JAMES	56.42
009668	GIBSON, MELISSA	56.00
020700	ROMERO, JOSUE	55.44
021494	TEMPLE, MARISSA NOEL	55.37
013936	BANDY, CHRISTINA LYNN	53.06

Blue Valley USD #229
Disbursements for September 2025

Vendor ID	Vendor Name	
004001	BROTHERSON, MARY ELIZABETH	52.64
017315	SATRIANO, JAMES ALAN	51.87
022150	ROBERTSON, LAURA KAY	51.52
P08732	STEWART, CHAD	50.05
074313	TRAVELERS	50.00
067278	WICHITA COLLEGIATE SCHOOL INC	50.00
015162	HOGAN, NICOLE RANAE	49.91
020627	HERN, STEPHANIE JEAN	49.70
014154	ASHER, TARA PAIGE	49.14
019058	MURO, DIANE CYNTHIA	49.00
060423	BLUE VALLEY ACADEMY	48.90
019375	CHAFIN, SONJA MARIE	48.16
021862	FARRINGTON, DANA MICHELE	48.16
023192	CORTEZ MORALES, CRISTINA J	48.02
068421	OLATHE NORTHWEST HIGH SCHOOL	48.00
012703	BUDNEY, MATTHEW JOHN	47.39
016213	HOLKER, HOLLY ANNE	47.25
007193	CLELAND, STEPHANIE	47.04
019195	GRAU, AMBER LYNN	46.20
002800	BLUE VALLEY MIDDLE SCHOOL	45.64
019593	MUNSON, STEPHANIE KATE	45.43
018850	PARRA, ELENIS	45.29
R01888	WRIGHT, CARRIE	42.25
013181	GRAHAM, JANET LYNN	40.60
023189	GARCIA-FLORES, KIMBERLY	40.39
013304	GEABHART, JASON ANDREW	38.64
022111	VICK, JAMES DEAN	38.22
054188	HARMONY MIDDLE SCHOOL	37.53
004094	MUNSON, REBECCA STITH	36.19
010844	HILL, CHRISTINE MARIE	35.14

Blue Valley USD #229
Disbursements for September 2025

Vendor ID	Vendor Name	
072229	BPA-KANSAS ASSOCIATION	35.00
022799	ASHCRAFT, DEBRA MORINE	35.00
009218	JOHNSTON, JODIE	33.74
008464	HARMS, JENNIFER LYNN	33.60
017719	KAUSAR, BILQEES	33.60
019621	WITTEBORG, KRISTIN MARIE	33.53
050435	OVERLAND TRAIL MIDDLE SCHOOL	33.06
009695	CHOPP, ELIZABETH ROSEN	32.90
009395	BUTLER, SUSAN	32.69
ABM	AUBRY BEND MIDDLE SCHOOL	32.10
022002	PARRISH, KARLA PATRICIA	32.06
003980	CHYKA, MICHEAL BRUCE	31.78
011107	BEVIL, BETH ANN	31.50
013642	BURNS, MELODY J	29.19
004880	NIELSEN, MICHELLE LYN	28.00
018344	PERLEY, ALYSSA C	27.72
009728	BUXTON, SHERI A	27.58
013281	COHEN, ERIC ALLEN	27.44
014992	KROUSE, CASEY ANNE	27.30
022065	HUCKABY, APRIL LOUISE	26.18
023250	BAGLEY, RACHEL ANN	26.04
007785	DICKENS, AMY CHRISTINE	25.90
015067	MARQUESS, STEPHANIE NICOLE	25.69
020059	HELGESON, MELINDA C	25.27
022006	MARSHALL, ZAKIAH	25.13
012162	HINMAN, LYNN KATHERYN	24.71
019754	RODDY, SARAH ANNE	23.94
007271	RICHARDSON, AMBER MARIE	22.82
023193	KOSPELICH, ROBIN ANNE	22.40
011058	THOMPSON, EMILY VIRGINIA L	22.26

Blue Valley USD #229
Disbursements for September 2025

Vendor ID	Vendor Name	
015909	KNIGHT, DONNA M	21.84
005592	CHRISTIAN, PATRICIA M	21.70
019381	DA VALINHA LOPES, ANDREA C	21.14
012091	MAYS, WENDY ANN	21.14
018134	MEISINGER, PEYTON JEAN	20.86
020748	TRIBALDO HENAO, KARENT	20.58
012790	HAMERA, AMY REBECCA	19.60
020518	KOCH, BARRET LUCAS	19.46
P13933	MURILLO, JANA	17.99
P13934	SELSER, CHRISSY	17.99
002447	SIMKINS, DEBORAH JEAN	17.99
015042	OAKES, SUZANNE	17.92
023138	ARAGON, SHAUNA MARIE	17.85
012171	BEICHLEY, KACI REBECCA	17.78
001666	HODGES, ROBIN KATHLEEN	17.36
006814	RANGEL, MONICA	16.94
021378	WILCOX, BROOKE E	16.38
021923	HALL, KAYLA LYNN	15.68
023041	MEYER, JASON E	15.68
015150	GUO, SU	15.54
022798	MANGINE, CHARLES DUANE	14.56
019717	GARRUSS, ANASTASIA R	13.58
011992	SIMPSON, LORIE SUZZANNE	13.30
015694	BOOK, ANDREW JOHN	12.74
021549	BIGGERSTAFF-WEST, TRENTON SCOT	12.60
022604	FANGMAN, TRISTAN LEIGH	12.60
023199	NG'ANG'A, HAIMIE ARMIDE	12.39
021605	COUSINS, JANETH A	11.90
015848	KERR, ROBERT A	11.34
021932	WHITE, NANCY R	11.34

Blue Valley USD #229
Disbursements for September 2025

Vendor ID	Vendor Name	
017399	CLAYBROOK, ANN	10.92
021861	DOMINICK, DIANE MARIA	10.92
016929	WESTCOTT, JOHNATHON THOMAS	10.08
017252	HUTCHISON, STACEY D	9.94
013641	GRAY, KRISTI LYNN	9.80
004143	WRIGHT, LISA ANN	9.80
019723	TROWBRIDGE, WHITNEY LEIGH	9.38
022980	VOTYPKA, KELLI BETH	9.38
020448	WHITE, BROOKLYN MARIE	8.96
020857	MINER, JACLYN ELENA	8.82
009855	SCHWAGERL, SANDRA	8.54
019420	VALENZUELA, MARIA M	8.47
018400	CHOI, HYANG O	8.40
021267	ERPELDING, JUDY ELLEN	8.40
013022	LI, JUNJIAN	8.26
016089	MIRANDA OCAMPO, SERGIO	8.19
019793	HUNDLEY, KATHRYN L	8.12
001777	OXFORD MIDDLE SCHOOL	7.75
009582	VALVERDE, BOBBI JO	7.56
013225	BAILEY, CHARLES A	7.14
005680	SMITH, ANNE M	6.79
020921	SAS, CONSTANTIN CATALIN	6.72
023142	HASSAN, SAJA OMRAN	6.30
023162	BRADY, ALEXIS	5.46
018752	WELCH, REGINA MAE	5.32
014482	DE LA CRUZ, SILVINA	5.18
015297	FREEMAN, LORI LYNN	4.90
022458	GAGNON, JODI LYNNE	4.83
019701	MITCHELL, ROSALIND ELAINE	4.76
023292	BACA, MICHELLE ANN	4.48

Blue Valley USD #229
Disbursements for September 2025

Vendor ID	Vendor Name	
015520	KASICK, ASHLEY NICOLE	4.20
022438	WALTERS, CHARDEL KEVA	2.80
062980	LAKEWOOD MIDDLE SCHOOL	2.59
022996	RICE, AUBREY M	2.31
GRAND TOTAL		60,743,998.55

Blue Valley Unified School District No. 229

RESOLUTION FOR DESTRUCTION OF RECORDS

BE IT RESOLVED THAT, the Board of Education of Unified School District No. 229, Johnson County, Kansas, hereby authorizes the clerk of the board to destroy the following records pursuant to [K.S.A. 72-1629](#) and [K.S.A. 72-1630](#).

List records to be destroyed.

- (a) Bookkeeping and accounting records, which are original books of entry, claims, vouchers, and purchase orders, five (5) years.
- (b) Formal audit reports, five (5) years.
- (c) Financial papers of any type relating to programs supported by federal funds, three (3) years or such longer time as may be required by applicable federal law.
- (d) All financial papers not otherwise specified in this section may be destroyed at any time after formal audit reports have been completed and filed in the appropriate offices for a period of six (6) months, and this provision shall apply to the following: Warrants, warrant checks, receipts, canceled checks, and requisitions.
- (e) Official bonds of surety or indemnity, five (5) years after the termination of the term of employment.
- (f) Insurance policies, five (5) years after the expiration of the term thereof.
- (g) Bonds and coupons stamped paid or canceled and returned by the state fiscal agent, six (6) months after the next following annual formal audit of the school district.

By:

Board Member

Board Member

Board Member

Board Member

Board Member

Board Member

Board Member

CERTIFICATE

This is to certify that the above resolution was duly adopted by the Board of Education of Unified School District No. 229, Johnson County, Kansas, on the 13th day of October 2025.

Clerk of the Board of Education

**TERMINATION AND RELEASE
OF
SANITARY SEWER CONSTRUCTION AND DEVELOPMENT AGREEMENT**

This TERMINATION AND RELEASE OF SANITARY SEWER CONSTRUCTION AND DEVELOPMENT AGREEMENT (this “**Termination Agreement**”), dated as of _____, 2025, (“**Effective Date**”) between Bonita Investors, LLC, a Kansas limited liability company (the “**Developer**”) and Unified School District No. 229, Johnson County, a political subdivision of the State of Kansas (“**School District**,” together with Developer the “**Parties**” and each a “**Party**”).

RECITALS

- A. The Parties entered into that certain Sanitary Sewer Construction and Development Agreement dated July 25, 2023, as amended by that certain Amendment to Sanitary Sewer Construction and Development Agreement February 10, 2025 (collectively the “**Development Agreement**”), for the construction of certain sanitary sewer facilities that serve the School District property (the “**Improvements**”) on the real property more particularly described in the Development Agreement (“**Property**”).
- B. On July 28, 2023, the Parties recorded a Memorandum of Sanitary Sewer Construction and Development Agreement in book 202307, page 007179, document number 20230728-007179 in the office of the Johnson County Register of Deeds (“**Memorandum**”), to provide notice of the Development Agreement.
- C. Pursuant to Section 5(i) of the Development Agreement, the School District will record a termination of the Development Agreement after the Improvements have been dedicated.
- D. The Improvements have been dedicated, and the Parties now desire to formally declare that each Party’s obligations have been completed and fulfilled and desire to mutually terminate the Development Agreement and the Memorandum on the terms and subject to the conditions set forth herein.

AGREEMENT

For good and valuable consideration, the receipt and sufficiency of which are hereby acknowledged, the Parties agree as follows:

- 1. **RECITALS.** The above Recitals are incorporated in this Termination Agreement as if fully set forth in this Section 1.
- 2. **DEFINITIONS.** Capitalized terms used and not defined in this Termination Agreement have the respective meanings assigned to them in the Development Agreement.
- 3. **TERMINATION OF THE DEVELOPMENT AGREEMENT.** The Development Agreement is hereby terminated as the Effective Date. From and after the Effective Date, the Development Agreement will be of no further force or effect, and the rights and obligations of each of the Parties thereunder shall terminate. This Termination Agreement shall be recorded in the office of the Johnson County Register of Deeds. Upon the recording of this Termination Agreement, the Memorandum shall terminate.

4. **MUTUAL RELEASE.** In consideration of the covenants, agreements, and undertakings of the Parties under this Termination Agreement, each Party, on behalf of itself and its respective affiliates, officers, directors, employees, members, successors, and assigns (collectively, “**Releasors**”) hereby releases, waives, and forever discharges the other Party and its respective affiliates, employees, officers, directors, members, agents, successors, and assigns (collectively, “**Releasees**”) of and from any and all causes of action, claims, losses, damages, liabilities, demands, costs, and expenses (collectively, “**Claims**”), which any of such Releasors ever had, now have, or hereafter can, shall, or may have against any of such Releasees attributable to, or arising out of, in any way the Development Agreement, except for any Claims relating to rights and obligations preserved by, created by, or otherwise arising out of this Termination Agreement.

5. **REPRESENTATIONS AND WARRANTIES.** Each Party hereby represents and warrants to the other Party that:
 - 5.1 It has the full right, power, and authority to enter into this Termination Agreement and to perform its obligations hereunder.
 - 5.2 The execution of this Termination Agreement by the individual whose signature is set forth at the end of this Termination Agreement on behalf of such Party, and the delivery of this Termination Agreement by such Party, have been duly authorized by all necessary action on the part of such Party.
 - 5.3 This Termination Agreement has been executed and delivered by such Party and constitutes the legal, valid, and binding obligation of such Party, enforceable against such Party in accordance with its terms.
 - 5.4 It (i) knows of no Claims against the other Party relating to or arising out of the Development Agreement that are not covered by the release contained in Section 4 and (ii) has neither assigned nor transferred any of the Claims released herein to any person or entity and no person or entity has subrogated to or has any interest or rights in any Claims.
 - 5.5 EXCEPT FOR THE EXPRESS REPRESENTATIONS AND WARRANTIES SET FORTH IN SECTION 5 OF THIS TERMINATION AGREEMENT, (A) NEITHER PARTY HERETO NOR ANY PERSON ON SUCH PARTY’S BEHALF HAS MADE OR MAKES ANY EXPRESS OR IMPLIED REPRESENTATION OR WARRANTY WHATSOEVER, EITHER ORAL OR WRITTEN, WHETHER ARISING BY LAW, COURSE OF DEALING, COURSE OF PERFORMANCE, USAGE OF TRADE OR OTHERWISE, ALL OF WHICH ARE EXPRESSLY DISCLAIMED, AND (B) EACH PARTY HERETO ACKNOWLEDGES THAT, IN ENTERING INTO THIS TERMINATION AGREEMENT, IT HAS NOT RELIED UPON ANY REPRESENTATION OR WARRANTY MADE BY THE OTHER PARTY, OR ANY OTHER PERSON ON SUCH OTHER PARTY’S BEHALF, EXCEPT AS SPECIFICALLY PROVIDED IN THIS SECTION 5.

6. **MISCELLANEOUS.**
 - 6.1 This Termination Agreement and all related documents, including all exhibits attached hereto, and all matters arising out of or relating to this Termination Agreement are governed by, and construed in accordance with, the laws of the State of Kansas, without giving effect to the conflict of laws provisions thereof.

- 6.2** This Termination Agreement may be executed in counterparts, each of which is deemed an original, but all of which constitutes one and the same agreement. Delivery of an executed counterpart of this Termination Agreement electronically or by facsimile shall be effective as delivery of an original executed counterpart of this Termination Agreement.
- 6.3** The headings in this Termination Agreement are for reference only and do not affect the interpretation of this Termination Agreement.
- 6.4** If any term or provision of this Termination Agreement is invalid, illegal, or unenforceable in any jurisdiction, such invalidity, illegality, or unenforceability shall not affect any other term or provision of this Termination Agreement or invalidate or render unenforceable such term or provision in any other jurisdiction. Upon such determination that any term or other provision is invalid, illegal, or unenforceable, the Parties shall negotiate in good faith to modify this Termination Agreement so as to effect the original intent of the Parties as closely as possible in a mutually acceptable manner in order that the transactions contemplated hereby be consummated as originally contemplated to the greatest extent possible.
- 6.5** This Termination Agreement constitutes the sole and entire agreement between the Parties with respect to the subject matter contained herein and supersedes all prior and contemporaneous understandings, agreements, representations, and warranties, both written and oral, with respect to such subject matter.
- 6.6** Each Party shall pay its own costs and expenses in connection with the drafting, negotiation, and execution of this Termination Agreement (including the fees and expenses of its advisors, accountants, and legal counsel).
- 6.7** This Termination Agreement benefits solely the Parties hereto and their respective successors and assigns, and nothing in this Termination Agreement, express or implied, confers on any other person or entity any legal or equitable right, benefit, or remedy of any nature whatsoever under or by reason of this Termination Agreement.

[Signature page follows]

**TERMINATION AND RELEASE
OF
STREET CONSTRUCTION AND DEVELOPMENT AGREEMENT**

This TERMINATION AND RELEASE OF STREET CONSTRUCTION AND DEVELOPMENT AGREEMENT (this “**Termination Agreement**”), dated as of _____, 2025, (“**Effective Date**”) between Bonita Investors, LLC, a Kansas limited liability company (the “**Developer**”) and Unified School District No. 229, Johnson County, a political subdivision of the State of Kansas (“**School District**,” together with Developer the “**Parties**” and each a “**Party**”).

RECITALS

- A.** The Parties entered into that certain Street Construction and Development Agreement dated March 9, 2023, as amended by that certain Amendment to Street Construction and Development Agreement dated July 25, 2023, and further amended by that certain Second Amendment to Street Construction and Development Agreement dated January 13, 2025 (collectively the “**Development Agreement**”), for the construction of certain public roadway facilities that serve both Developer the School District property (the “**Improvements**”) on the real property more particularly described in the Development Agreement (“**Property**”).
- B.** On March 14, 2023, the Parties recorded a Memorandum of Street Construction and Development Agreement in book 202303, page 002652, document number T20230008217 in the office of the Johnson County Register of Deeds (“**Memorandum**”), to provide notice of the Development Agreement.
- C.** Pursuant to Section 5(i) of the Development Agreement, the School District will record a termination of the Development Agreement after the Improvements have been completed.
- D.** The Improvements have been completed, and the Parties now desire to formally declare that each Party’s obligations have been completed and fulfilled and desire to mutually terminate the Development Agreement and the Memorandum on the terms and subject to the conditions set forth herein.

AGREEMENT

For good and valuable consideration, the receipt and sufficiency of which are hereby acknowledged, the Parties agree as follows:

- 1. RECITALS.** The above Recitals are incorporated in this Termination Agreement as if fully set forth in this Section 1.
- 2. DEFINITIONS.** Capitalized terms used and not defined in this Termination Agreement have the respective meanings assigned to them in the Development Agreement.
- 3. TERMINATION OF THE DEVELOPMENT AGREEMENT.** The Development Agreement is hereby terminated as the Effective Date. From and after the Effective Date, the Development Agreement will be of no further force or effect, and the rights and obligations of each of the Parties thereunder shall terminate. This Termination Agreement shall be recorded in the office of the Johnson

County Register of Deeds. Upon the recording of this Termination Agreement, the Memorandum shall terminate.

4. **MUTUAL RELEASE.** In consideration of the covenants, agreements, and undertakings of the Parties under this Termination Agreement, each Party, on behalf of itself and its respective affiliates, officers, directors, employees, members, successors, and assigns (collectively, “**Releasors**”) hereby releases, waives, and forever discharges the other Party and its respective affiliates, employees, officers, directors, members, agents, successors, and assigns (collectively, “**Releasees**”) of and from any and all causes of action, claims, losses, damages, liabilities, demands, costs, and expenses (collectively, “**Claims**”), which any of such Releasors ever had, now have, or hereafter can, shall, or may have against any of such Releasees attributable to, or arising out of, in any way the Development Agreement, except for any Claims relating to rights and obligations preserved by, created by, or otherwise arising out of this Termination Agreement.
5. **REPRESENTATIONS AND WARRANTIES.** Each Party hereby represents and warrants to the other Party that:
 - 5.1 It has the full right, power, and authority to enter into this Termination Agreement and to perform its obligations hereunder.
 - 5.2 The execution of this Termination Agreement by the individual whose signature is set forth at the end of this Termination Agreement on behalf of such Party, and the delivery of this Termination Agreement by such Party, have been duly authorized by all necessary action on the part of such Party.
 - 5.3 This Termination Agreement has been executed and delivered by such Party and constitutes the legal, valid, and binding obligation of such Party, enforceable against such Party in accordance with its terms.
 - 5.4 It (i) knows of no Claims against the other Party relating to or arising out of the Development Agreement that are not covered by the release contained in Section 4 and (ii) has neither assigned nor transferred any of the Claims released herein to any person or entity and no person or entity has subrogated to or has any interest or rights in any Claims.
 - 5.5 EXCEPT FOR THE EXPRESS REPRESENTATIONS AND WARRANTIES SET FORTH IN SECTION 5 OF THIS TERMINATION AGREEMENT, (A) NEITHER PARTY HERETO NOR ANY PERSON ON SUCH PARTY’S BEHALF HAS MADE OR MAKES ANY EXPRESS OR IMPLIED REPRESENTATION OR WARRANTY WHATSOEVER, EITHER ORAL OR WRITTEN, WHETHER ARISING BY LAW, COURSE OF DEALING, COURSE OF PERFORMANCE, USAGE OF TRADE OR OTHERWISE, ALL OF WHICH ARE EXPRESSLY DISCLAIMED, AND (B) EACH PARTY HERETO ACKNOWLEDGES THAT, IN ENTERING INTO THIS TERMINATION AGREEMENT, IT HAS NOT RELIED UPON ANY REPRESENTATION OR WARRANTY MADE BY THE OTHER PARTY, OR ANY OTHER PERSON ON SUCH OTHER PARTY’S BEHALF, EXCEPT AS SPECIFICALLY PROVIDED IN THIS SECTION 5.
6. **MISCELLANEOUS.**
 - 6.1 This Termination Agreement and all related documents, including all exhibits attached hereto, and all matters arising out of or relating to this Termination Agreement are governed by, and

construed in accordance with, the laws of the State of Kansas, without giving effect to the conflict of laws provisions thereof.

- 6.2 This Termination Agreement may be executed in counterparts, each of which is deemed an original, but all of which constitutes one and the same agreement. Delivery of an executed counterpart of this Termination Agreement electronically or by facsimile shall be effective as delivery of an original executed counterpart of this Termination Agreement.
- 6.3 The headings in this Termination Agreement are for reference only and do not affect the interpretation of this Termination Agreement.
- 6.4 If any term or provision of this Termination Agreement is invalid, illegal, or unenforceable in any jurisdiction, such invalidity, illegality, or unenforceability shall not affect any other term or provision of this Termination Agreement or invalidate or render unenforceable such term or provision in any other jurisdiction. Upon such determination that any term or other provision is invalid, illegal, or unenforceable, the Parties shall negotiate in good faith to modify this Termination Agreement so as to effect the original intent of the Parties as closely as possible in a mutually acceptable manner in order that the transactions contemplated hereby be consummated as originally contemplated to the greatest extent possible.
- 6.5 This Termination Agreement constitutes the sole and entire agreement between the Parties with respect to the subject matter contained herein and supersedes all prior and contemporaneous understandings, agreements, representations, and warranties, both written and oral, with respect to such subject matter.
- 6.6 Each Party shall pay its own costs and expenses in connection with the drafting, negotiation, and execution of this Termination Agreement (including the fees and expenses of its advisors, accountants, and legal counsel).
- 6.7 This Termination Agreement benefits solely the Parties hereto and their respective successors and assigns, and nothing in this Termination Agreement, express or implied, confers on any other person or entity any legal or equitable right, benefit, or remedy of any nature whatsoever under or by reason of this Termination Agreement.

[Signature page follows]

BLUE VALLEY SCHOOLS

ACADEMICS & ACTIVITIES

BOARD ADVISORY COMMITTEE

MEETING MINUTES

Thursday, September 18, 2025 | 7:30 a.m. – 9:00 a.m.

Board of Education Room | 15020 Metcalf Avenue | Overland Park, KS

FACILITATOR(S): Dr. Katie Collier, Kelly June & Matt Ortman

COMMITTEE MEMBERSHIP: Philon Barr-Manning, Brenna Bidwell, Kaci Brutto, Sean Burrell, Dr. Katie Collier, Brooke Davids, Jodie Dietz, Lauren Dreher, Kim Grosdidier, Amy Hill, Ryan Hussey, Kelly June, Gina Knapp, Ayden McGibboney, Tvisha Nair, Adrienne Newlin, Lucia Noll, Ava Middleton, Clay Norkey, Matt Ortman, Nova Rule, Brittany Verrett, Matt Wachel, and Melody Xue

WELCOME & ORIENTATION

Kelly June and Dr. Katie Collier welcomed the committee members and shared the purpose of the committee. Members introduced themselves and the Board members shared some opening remarks.

DISTRICT STRATEGIC PLAN

Dr. Katie Collier provided high-level information about key components of the new District Strategic Plan and the process the community and district went through to create it.

MAJOR INITIATIVES & THE WORK OF 2025–26

Kelly June shared information related to the work that was accomplished in the last

school year as part of the last strategic plan and projects on the horizon and in progress for the current school year.

COMMITTEE MEETING SUMMARY & TALKING POINTS

The committee meeting opened with introductions from Kelly June, remarks from BOE member Clay Norkey, and member introductions. Norkey provided a board update, highlighting the hiring of a new superintendent, budget approval, and the importance of fully funding SPED.

Dr. Katie Collier presented the district's new five-year strategic plan, built on the core values of student-centeredness, excellence, and community, with three strategic priorities: advancing academic excellence and student experiences, fostering supportive and healthy school communities, and empowering exemplary educators. She outlined recent and upcoming facilities projects in athletics and activities, as well as efforts to strengthen supplemental pay for coaches.

Kelly June shared academic updates, including structured literacy adoption, expanded Career Ready Programs, new Individual Plans of Study, MTSS implementation, and a high school math symposium, with a focus this year on the middle school experience, math interventions, and screen time guidelines.

Committee members asked questions about Career Ready Programs and MTSS and suggested future topics such as student mental health, activity burnout, counselor roles, transitions to high school, parent resources, course offerings, and support for transfer students.

The meeting closed with next steps, noting that the Oct. 16 meeting will cover new high school courses, Career Ready programming, and extra/co-curricular review.

NEXT MEETING

The next meeting will be held on OCTOBER 16.

The meeting adjourned at 8:45 a.m.

BLUE VALLEY SCHOOLS

FINANCE AND OPERATIONS BOARD ADVISORY COMMITTEE

MINUTES

OCTOBER 9, 2025 @ 7:30am

DISTRICT OFFICE COMMONS

FACILITATOR(S):

Jake Slobodnik, Executive Director of Operations

COMMITTEE MEMBERSHIP:

Patrons: Elizabeth Webb, Tom Robinett, Brenda Stasiulis, Louis Pisani, Ryan Rutkowski, Megan Senatore, Cassie Banka, Stephanie Heckart, Sara Holmes, Lauren Garcia, Matthew Misch, Daniel Mayer, Stephanie James, Kelly Arvin Harrison

Board Members: Jim McMullen, Clay Norkey, Sonya Evans

Staff: Jake Slobodnik, Jeremy McFadden, Kyle Hayden, Dr. Gillan Chapman, Dr. Eric Punswick, Jason Gillam, Kaci Brutto, Carrie Myers, Brian Daley, Kelly June, Charles Rathbun

Strategic Plan Connection(s):

Empowering exemplary educators and staff – by informing decisions around compensation, staffing and operational support that promote a positive and thriving workplace.

Fostering supportive and healthy school communities – by ensuring facilities and operations contribute to safe and well-maintained environments for students and staff.

TOPIC 1

Jake Slobodnik, Executive Director of Operations welcomed the committee members and reviewed the agenda.

TOPIC 2

Jake Slobodnik, Executive Director of Operations presented the 2024-25 Design and Construction Update reviewing all capital improvements in the last year.

TOPIC 3

Jason Gillam, Director of Business Operations, presented the purchasing memo as shown below.

NEXT MEETING

The next meeting will be held on November 6, 2025.

PURCHASES \$500,000 & ABOVE

Delta Dental of Kansas Inc

<u>2025</u>	<u>2026</u>
\$1,589,014.00 Est	\$1,628,495.00 Estimated

2026 Employee group dental insurance contract and renewal letter with Delta Dental of KC. 2.5% renewal increase for base and buy-up plans.

Estimated 2026 employee cost for base plan: 1,298,147.00.

Estimated 2026 employee cost for buy-up plan: 330,348.00

Funds: Employee Paid Benefit

Service Purchases

The Standard Insurance Company

<u>2025</u>	<u>2026</u>
\$1,321,198.00 Est	\$617,857.00 Estimated

The Standard insurance policies for 2026. Cost is based upon projected participation & employee-paid premium rates for all products. Prior year cost includes short-term and long-term disability, which are reported separately for 2026. Submission of 2026 insurance policies for:

- Voluntary Group Term Life (GTL) - 2026 Est. Annual \$435,306 (Renewal)
- Accident Insurance (AI) - 2026 Est. Annual \$66,694 (Renewal)
- Hospital Insurance (HI) - 2026 Est. Annual \$65,670 (Renewal)
- Critical Illness Insurance (CI) - 2026 Est. Annual \$50,187 (Renewal)

Funds: Employee Paid

Service Purchases

DESIGN & CONSTRUCTION PURCHASES

Blue River Elementary Playground Overlay & Restriping \$54,370.00 Estimated
Vendor: McConnell & Associates Corp
Cooperative: TIPS #23060201
Location: BRE
Anticipated Funding: Bond

BVNW Design and Construction Administration Services \$132,000.00 Estimated
Vendor: KC Architects LLC
Location: BVNW
Anticipated Funding: Bond

MLT 2602 – Painting Project \$67,500.00 Estimated
Vendor: Hollis & Miller Architects Inc
Location: BVNW, BVM, IVE, OHE
Anticipated Funding: Capital Outlay

STL 2501 – Site Improvements \$471,000.00 Estimated
Vendor: Hollis & Miller Architects Inc
Location: STIL
Anticipated Funding: Bond

BIDS

Emergency Purchase – Fiber struck \$30,088.08
Vendor: K&W Underground
Location: ITS
Funds: Capital Outlay

E-Rate FCC Form 470 Number 250011237 Network Equipment \$50,905.00 Estimated
Vendor: CDW Government Inc.
Location: ITS
Funds: Bond

26015 Compressors		\$30,568.75
Vendor: United Refrigeration Inc.		
Location: BG		
Funds: Capital Outlay		
26016 A/V Equipment for Wolf Springs Middle		\$304,432.52 Estimated
Vendor: Kansas City Audio Visual		
Location: WSM		
Funds: Bond		
26017 Forensic Supplies		\$38,301.00
Vendor: Amplyus LLC.		
d/b/a MiniPCRBio		
Location: BVH		
Funds: Breakthrough Grant		
26018 Science Supplies		\$34,127.29
Vendors: Flinn Scientific Inc.	\$4,451.27	
School Specialty	\$180.06	
VWR International	\$ 1,017.72	
Fisher Scientific Co.	\$12,443.88	
Carolina Biological	\$15,900.86	
Unimak Corp.	\$133.50	
Location: BVH		
Funds: Breakthrough Grant		

COOPERATIVE PURCHASES

Athco		\$35,305.80
Purchase of shade structure for Blue River Elementary.		
Cooperative: Greenbush 24.6 ESC-PLAYGROUND-REC2024		
Funds: Capital Outlay		

Brady Industries of Kansas LLC \$65,576.00
This purchase of two robotic scrubbers, one for Aubry Bend Middle and one for Pleasant Ridge Middle.
Cooperative: Omnia Partners #R211301
Funds: Capital Outlay

CDW Government Inc \$166,736.00 Estimated
This purchase of wireless network equipment will support the new Wolf Springs Middle School. 026-013
Cooperative: Greenbush 025-F
Funds: Bond

CDW Government Inc \$266,545.00 Estimated
This purchase will support the A/V projectors refresh project at the Hilltop Learning Center. 026-025
Cooperative: Greenbush 025-F
Funds: Bond

Commercial Aquatic Services Inc \$28,354.22
Updating Gen 6 timing system for swim meets to Gen 7 for all pools in the district.
Cooperative: TIPS #230203
Funds: Capital Outlay

Commercial Aquatic Services Inc \$38,455.60
143081-C-L CTS Backstroke Start Device Long Bracket for all pools in the district this device will help with better take off in back stroke position.
Cooperative: TIPS #230203
Funds: Capital Outlay

Facilities Management Express LLC \$29,404.62
This purchase is for maintenance request, preventative maintenance, and standard dashboard software (Go FMX).
Cooperative: TIPS #220105
Funds: Capital Outlay

Insight Global LLC \$83,200.00 Estimated
This will provide 2 desktop support personnel for future use if needed for a 180 Day contract.
1040 x 2 = 2080 X \$40.00 per hour for a total of \$83,200. 26-027
Cooperative: Omnia Partners 2021003051
Funds: Capital Outlay

Ready2Go Trailer Sales LLC \$136,734.00
Purchase of two station restroom trailers for use at construction projects.
Cooperative: Sourcewell 092922-AGO
Funds: Capital Outlay

Virco Inc \$30,000.00 Estimated
Purchase of 20 sewing machine tables for Wolf Springs Middle.
Cooperative: Omnia Partners R-TC-18004
Funds: Bond

SERVICE PURCHASES

Allstate Identity Protection

<u>2025</u>	<u>2026</u>
\$83,970.00 Est.	\$87,173.00 Estimated

Renewal for 2026 employee paid All State Identity Protection. No rate change for 2026. Cyber protection offered to employees for personal devices. Features of cyber protection include: personal computer safety, webcam protection, firewall, antivirus, browsing and phishing protection, web filtering, VPN, password manager, and network security.

2026 renewal cost: \$10.96/employee only; \$18.96/family.

Funds: Employee Paid Benefit

ARAG LLC

2025

2026

\$46,649.00 Est.

\$51,607.00 Estimated

ARAG Legal Insurance for 1/1/2026. One monthly rate for employee and covered dependents of \$18.78 per month. ARAG Legal insurance provides a network of attorneys for personal legal matters for employees and covered family members across a variety of needs (family, home, auto, estate planning, elder law, consumer protection, criminal situations, divorce, finance & tax, traffic & other general personal legal needs). 2026 cost: \$18.78 per month premium rate (employee and dependents). Under rate guarantee, 1/1/2025-12/31/2028. Paid for by the employee via payroll.

Funds: Employee Paid Benefit

The Brighthouse Academy LLC

2024/2025

2025/2026

N/A

\$25,650.00 Estimated

Student (FC) will be attending Brighthouse Academy for hourly transition services (up to 10 hours/week) for the 25-26 school year. This is an IEP decision.

Funds: SPED

The Brighthouse Academy LLC

2024/2025

2025/2026

N/A

\$25,650.00 Estimated

Student (JR) will be attending Brighthouse Academy for the remainder of the 25-26 school year. This is an IEP decision.

Funds: SPED

CBIZ Benefits and Insurance Services Inc

2025

2026

\$74,371.00 Est.

\$78,170.00 Estimated

Voluntary retirement savings plans - 403 (b) Plan and 457(b) Plans Servicing Agreement, effective 1/1/2026. Employee paid fees via plan enrollment.

Funds: Employee Paid Benefit

Fritz Painting & Drywall LLC

2024/2025

2025/2026

\$95,481.00

\$50,000.00 Estimated

Purchase painting services to fulfill painting needs outside of the patch and paint repair needs scope in the District.

Funds: Capital Outlay

Research Institute for Learning and Development

2024/2025

2025/2026

N/A

\$15,750.00 Additional Est.

\$53,970.00 Revised Est. Total

Originally reported in June 2025. Purchasing 3 SMARTS CONNECT HS and 3 SMARTS CONNECT MS site licenses allows for 1 common login to access SMARTS CONNECT MS and 1 common login to access SMARTS CONNECT HS. This login is to be used by any and all MS and HS Special Education Staff in the District. The institutional licenses allow for multiple simultaneous log-ins.

Funds: SPED

Signature Landscape LLC

2024/2025

2025/2026

N/A

\$30,000.00 Estimated

Parking lot snow removal services as needed through December 31, 2025.

Funds: Capital Outlay

The Standard Insurance Company

2025

2026

\$356,766.00 Est.

\$430,333.00 Estimated

Submission of The Standard 2026 insurance policy for short-term disability and long-term disability.

2026 STD renewal cost \$391,502 - 23% rate increase

2026 LTD renewal cost \$38,831 - no rate increase

Funds: Special Reserve Healthcare

Supplemental Health Care Services

2024/2025

2025/2026

N/A

\$29,000.00 Addl Est

\$65,000.00 Rev Total Est

1) SLP to cover for maternity leave at WSE 8/10-10/15/25

2) Newly added vacancy at HES from 10/17-12/19/25

Original amount: \$36,000

Increase needed: \$29,000

Total revised amount: \$65,000

Funds: SPED

Surency Life & Health Insurance Co

2025

2026 – 2030

\$305,905.00 Est.

\$317,190.00 Estimated Annual

2026 Employee paid group vision insurance contract and renewal letter with Surency Life and Health. No rate changes

Funds: Employee Paid

Varsity Spirit LLC / Southwest Airlines Co

2024/2025

2025/2026

\$33,388.26 Est.

\$33,000.00 Estimated

The BVN Dance Team will attend the NDA National Championships in Orlando, FL from 2/12-17/26. They will compete at the highest level of dance in the nation. Costs include room/board, meals, airfare, and ground transportation. Estimated costs:

Varsity Spirit/National Dance Alliance (Registration/Lodging): ~\$19,700.00 (final prices have yet to be released)

Southwest Airlines: \$7,296.48

Happy Limo: \$1,500

Meals: ~\$3,000

Funds: Activity Fund

Water District No. 1 of Johnson County

2024/2025

2025/2026

N/A

\$0.00

This agreement is between Blue Valley School District and the water utility company, WaterOne, to establish a permanent easement at Wolf Springs Middle School along 175th street for future water line development.

Funds: N/A

BLUE VALLEY SCHOOLS

COMMUNITY BOARD ADVISORY COMMITTEE MEETING

MINUTES

September 22, 2025

4:00 – 5:30 p.m.

District Office Board Room

FACILITATOR(S): Dr. Katie Collier, Deputy Superintendent

COMMITTEE MEMBERSHIP:

Anna Custer-Singh, Caroline Chaboo, Jonathan Freiden, Kelly Selznick, Natalie Svilarich, Courtney Carlson, Kimberley Kushner, Sarah Cullor, Celia Byers, Colleen Cunningham, Jennifer Glanzer, Kristin Gembala, Abby O'Neill, Kelly Beck, Julia Bernard, Josh Heizman, Renee Meares, Jennifer Nowak, Pam Shernuk, Wendy Connelly, Dr. Sonya Evans, Patrick Hurley, Jodie Dietz, Dr. Katie Collier, Dr. Mark Schmidt, Kaci Brutto, Shahzad Zafa, Neta Meltzer, Carolina Salguero, Ella Rogers, Manuel Onentia, Joselyn Selser, Cale Fulcher, Mete Berkoz, Sama Salim, Kate Ingram, Tristan Coates, Laura Darwish, Sriha Penugonda

Strategic Plan Connection(s):

- **Fostering supportive and healthy school communities – by promoting mental health, safety and a sense of belonging.**
- **Empowering exemplary educators and staff – by supporting a collaborative school culture where all staff can thrive.**

TOPIC 1

Introduction to the Community Board Advisory Committee: The committee reviewed the development of the Strategic Plan process. Priorities within the Strategic Plan were reviewed. Board Goals for '25-'26 were highlighted. Organizational structures were presented which ensure buildings are aligned to and focused on Strategic Plan

priorities and goals.

TOPIC 2

Suicide Prevention: The committee was provided an overview of district partnerships and district actions that are aimed at providing education and prevention of deaths by suicide. The committee provided feedback on current practices and had the opportunity to ask questions to gain a broader understanding of district efforts relative to supporting the mental health needs of student and staff.

TOPIC 3

Family Resources: Committee members received an overview of potential additional resources that could be made available for students and families. Committee members will provide feedback to help inform how the district will utilize these additional mental health family resources along with how access to these resources can be communicated to families to ensure awareness and access.

COMMITTEE MEETING SUMMARY & TALKING POINTS

The following were meeting take aways:

- **Members became familiar with each other.**
- **The purpose of the committee along with related Strategic Plan goals were reviewed.**
- **An update was provided regarding efforts associated with suicide prevention.**
- **Feedback from committee members was requested regarding availability of resources for parent access.**
- **The committee previewed the next agenda topics which will include understanding school culture and bullying prevention.**

NEXT MEETING

The next meeting will be held on October 27th. The meeting adjourned at 5:30 p.m..



October 2025 Celebrations Update

DISTRICT

In the 2026 Niche rankings, Blue Valley Schools was once again ranked within the **top 1% of school districts in the nation.**

The district was recognized as the **#1 school district in Kansas** and the **#1 district with the best teachers in Kansas.**

TOP 1%
BEST SCHOOL
DISTRICT IN NATION



DISTRICT

51 Blue Valley seniors were named semifinalists in the 2025 National Merit Scholarship Program, the most of any district in Kansas.



DISTRICT

Blue Valley Schools was named **Best**

Public School in Kansas City

Magazine's Best of KC 2025.



DISTRICT

In this season premiere of BV Unmuted, new Superintendent **Dr. Gillian Chapman** shares how she ended up at Blue Valley, her vision for the district and more — with help from students **PJ Cocherl**, **Penelope Mowatt** and **Madison Kraft**.

www.tinyurl.com/BVSuptQA



DISTRICT

The **Blue Valley Today: Fall 2025** issue was delivered to district mailboxes:

- *First day of school*
- *Leading with purpose: A conversation with Dr. Gillian Chapman*
- *Cultivating Blue Valley: Strategic Plan*

www.tinyurl.com/BVTodayFall25



DISTRICT

Blue Valley Schools achieved the following **2025 Kansans Can Star**

Recognition Program honors:

- 2025 Commissioner's Award – Commissioner's Award with Honors
- Graduation – Gold
- Postsecondary Effectiveness – Gold
- Academically Prepared for Postsecondary – Silver



DISTRICT

On Count Day, the total K-12 enrollment for the 2025-26 school year was **21,563**

students. The total cohort growth was 366 students.



DISTRICT

Blue Valley Schools is preparing to launch a **new district website** and new **school websites** this week.

**NEW WEBSITE
COMING SOON!**



DISTRICT

October Recognition Dates & Holidays

- National Bullying Prevention Month
- National High School Activities Month
- National Principals Month
- 10/2: Custodian Appreciation Day
- 10/6: National Coaches Day
- 10/13-17 : National School Lunch Week



STUDENT

Sriram Srinivasa Kalki, a 2025 graduate of Blue Valley North, and **Leena Dudi**, a 2025 graduate of Blue Valley West, were named 2025 U.S. Presidential Scholars. Only 161 students earned this prestigious distinction.



STUDENT

Blue Valley high schools had an exceptional night of music at the district's 43rd annual Marching Band Festival.



STUDENT

Blue Valley High's **Mabel Craig** was selected to perform at the Cohutta Song Fest, a two-day music event in northwest Georgia that showcases both established and emerging singer-songwriters. Craig was also named a youth finalist in the festival's songwriting competition.



Cohutta Song Fest

STAFF

Indian Valley Elementary's **Maddie Carter** and Blue Valley Northwest's **Blaise Smith** were selected as the district's nominees for the 2026 Kansas Horizon Award.

The Kansas State Department of Education award program recognizes up to 32 exemplary educators who excelled in a manner that sets them apart as outstanding during their first year in the classroom.



STAFF

Lakewood Elementary's **Madison Cundiff** and Blue Valley High's **Kimberly Thompson** have been selected as Blue Valley's nominees for the 2027 Kansas Teacher of the Year award.

The Kansas State Department of Education award program recognizes exemplary classroom teachers with five or more years of experience who are leaders in improving schools, student performance and the teaching profession.



STAFF

Harmony Elementary's **Abigail Buser** and Blue Valley West's **Heather Hall** have been selected to represent the district for the 2026 Kansas Master Teacher award.

The award program, established by Emporia State University in 1954, recognizes excellence in seven Kansas educators each year.



STAFF

Overland Trail Middle's **Taylor Mills** was named to the inaugural roster of the KC Astras, the newest indoor soccer club in the Major Arena Soccer League Women (MASLW).



ACTIVITIES & ATHLETICS

The **Blue Valley West Marching Band** was invited by the organizers of the London Parade and Festival 2027 to travel to and participate in the event.



BLUE VALLEY SCHOOLS



Board of Education Update | October 13, 2025

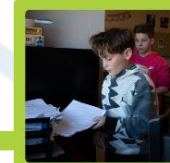

Strategic Plan **PRIORITIE**



Advancing Academic Excellence & Exceptional Student Experiences

This priority ensures that all students will have access to rigorous, innovative, and equitable educational opportunities that prepare them for future success. By creating engaging and memorable experiences, the district fosters a learning environment where students are inspired to grow academically, socially and personally.



Empowering Exemplary Educators and Staff

This priority reflects the district's commitment to attracting, developing, and retaining exceptional educators who are essential to student success. By investing in professional growth, promoting well-being, and cultivating a supportive culture, the district empowers its team to thrive. Strong relationships, trust, and a shared sense of purpose create a workplace where every staff member feels valued and equipped to make a meaningful impact.



Fostering Supportive and Healthy School Communities

This priority centers on creating school environments where every student and staff member feels safe, supported, and valued. By prioritizing mental health, well-being and safety, the district cultivates conditions for meaningful learning and personal growth.





Priority:

Advancing Academic Excellence and Exceptional Student Experiences

Quality Instruction:

Blue Valley will maintain a culture of **high expectations** by providing all students with access to grade level standards and high-quality instructional materials which will yield **academic excellence** and exemplary experiences for all.

ACTION STEP UPDATE:

Support and monitor student learning growth, particularly for on-level learners in the area of math and English language arts (ELA).

- **MATH**
 - Standards alignment work is taking place with teachers and principals
 - Review and analysis of secondary math resource(s)
- **ELA**
 - Implementation of K-5 ELA resource adoption
 - High school ELA work focused on on-level learners



**Priority:**

Advancing Academic Excellence and Exceptional Student Experiences

ACTION STEP UPDATE:

Explore the creation of a Center for Advanced Professional Studies (CAPS) middle school model.

- Exploring current practices with CAPS Network affiliate partners
- Launched a book study with middle school principals
- Planning to anticipate launch of pilot experiences at WSMS
- Consideration of flexibility for varied experiences within the middle school schedule
- Developing an implementation concept that combines:
 - Experiences that enhance student outcomes for middle school students
 - Creation of new events that inject authenticity and relevance into the middle school experience while building durable skills



Priority:

Advancing Academic Excellence and Exceptional Student Experiences

ACTION STEP UPDATE:

Respond to enrollment and Career Ready Program needs by analyzing and recommending potential facility needs for multiple pathways in order to centralize and maximize district programming.

- Activated a program evaluation
- Analyzing enrollment trends
- Studying student survey interest data
- Analyzing labor market trends and needs
- Considering K-12 industry trends and practices in the areas of Career Technical Education and Career Ready Programming
- Gathering industry partner feedback and input
- Anticipate first semester recommendation



Priority:

Advancing Academic Excellence and Exceptional Student Experiences

ACTION STEP UPDATE:

Analyze district **transportation opportunities to increase student access to CAPS and all Career Ready Programming opportunities.**

- Analyze participation trends and transportation needs along with the associated impact on enrollment (with and without options)
- Consider options to create more flexibility for students within the high school bell schedule
- Considering the implications of phased in or immediate approach

**Priority:**

Advancing Academic Excellence and Exceptional Student Experiences

ACTION STEP UPDATE:

Expand implementation of Individual Plans of Study at the high school level to assist students in progressing towards their graduation and post-secondary goals.

- Continuation of High School Study work
- Scope and sequence progression completed by grade level
- Finalizing infrastructure supports for students and staff
- Anticipate an update of products during the December Board of Education workshop



Priority:

Advancing Academic Excellence and Exceptional Student Experiences

ACTION STEP UPDATE:

Implement district-provided device screen time recommendations.

- Conduct industry research along with recommendations from various associations
- Review outcomes of Kansas Screentime Task Force
- Completed Kansas survey regarding district-issued student devices analyzing student use across the state
- Gather feedback from a variety of stakeholders
- Anticipated fourth quarter recommendation for Fall 2026 implementation



Priority:

Advancing Academic Excellence and Exceptional Student Experiences

ACTION STEP UPDATE:

Provide initial guidance and professional learning regarding guidelines for instructional uses of artificial intelligence (AI).

- Graduated approach to bring on AI in various settings with various groups.
- Differentiated goals for different stakeholder groups (educators, students, leaders, etc.)
- Use of a Think Tank and Advisory group to engage wide spectrum of stakeholders.
- “People First”: A human-centered approach to AI in learning that leverages teachers, focuses on ethics and gives students skills needed for their futures.
- Community input used to inform AI usage in the classroom.
- Initial guidance communication anticipated Fall 2026.
- Ongoing multifaceted action steps.

**Priority:****Fostering Supportive and Healthy School Communities****ACTION STEP UPDATE:**

Maintain and expand coordinated mental health resources for students and families.

- Consulting with additional foundations which emphasize mental health resource coordination and availability
- Exploring a library of mental health and suicide prevention resources that may be accessible via the district and school web pages
- Gathering feedback from Community Board Advisory committee members
- Training for administrators and mental health team members regarding Suicide Assessment training updates for 2025-26

**Priority:****Fostering Supportive and Healthy School Communities****ACTION STEP UPDATE:****Implement and monitor ongoing revisions to At-Risk and Federal Title I programming.**

- Engaging with the state to ensure compliance with at-risk procedures
- Reviewing evidence-based practices eligible for at-risk funding
- Reviewing other opportunities for at-risk expenditures
- Implementing family liaison position at Indian Valley Elementary (Title)
- Adjusting to a flexible model to support needs of students and families that may attend a designated Title I school (IVE)



Priority:

Empowering Exemplary Educators & Staff

Exemplary Staff:

Attract and retain exceptional professionals who inspire student success and enrich our school communities.

ACTION STEP UPDATE:

Curate employee well-being, value and sense of belonging

Don't miss the free BV Virtual Vitality Conference!

Treat yourself after conferences and enjoy Blue Valley's free virtual vitality well-being event like no other!  Learn about topics to enhance your physical, financial and mental well-being.

Presentations are offered on the hour, every hour from 8 a.m. - 2 p.m. on Friday, Oct. 24 on topics such as:

- Hormones and the Heart
- Educator Financial Well-Being for Retirement
- KPERS 1 & 2 and KPERS 3
- Vitality Through Yoga (Virtual class)
- Healthy Eating on a Budget
- Social Media Readiness
- Foundations of Caregiving
- Estate Planning
- From Surviving to Thriving
- How Stress Affects Your Body
- Overview of Benefits/Q&A Breakout Sessions



Priority:

Empowering Exemplary Educators & Staff

Exemplary Staff:

Attract and retain exceptional professionals who inspire student success and enrich our school communities.

ACTION STEP UPDATE:

Curate employee well-being, value and sense of belonging

Explore, learn and enroll at the Benefits Fair!

Mark your calendars for Tuesday, Oct. 7 and Wednesday, Oct. 8 from 2-6 p.m. for the [Employee Benefits Fair](#). 🎉 The fair will be held in the High Plains Room at the district office campus.

- Learn all about [what's new](#) for 2026 benefits.
- Get your questions answered by our benefits vendors and the Blue Valley Benefits department.
- Learn about health, dental, vision, HSA and FSA eligibility, life insurance, accident insurance, hospital indemnity, critical illness, short-term disability, ID theft and cybersecurity protection, legal insurance and Kansas Public Employees Retirement System (KPERs).
- Enroll with technology on site.
- Enter to win free raffles donated by community partners.
- Enjoy a donated chair massage! Massages will be available by the Commons on Tuesday, Oct. 7 from 2-5 p.m. and Wednesday, Oct. 8 from 4-6 p.m.



Priority:

Empowering Exemplary Educators & Staff

Exemplary Staff:

Attract and retain exceptional professionals who inspire student success and enrich our school communities.

ACTION STEP UPDATE:

Curate employee well-being, value and sense of belonging

Wear pink for National Breast Cancer Awareness Month!

Join us on Thursday, Oct. 8 for National Hero Day and wear pink in support of National Breast Cancer Awareness Month. ❤️ Thank you to the Blue Valley Building Well-being Champions who have placed [hero posters](#) in staff lounges! Grab one to fill out in honor or memory of someone who has impacted your life.

Check it off your list: Mammogram spots still open!

There is still time to grab a screening time at our [2025 Blue Valley Schools Annual Mammogram Event](#) at Diagnostic Imaging Centers, Overland Park Clinic (6650 W. 110th St. #100, Overland Park, KS 66211). ❤️ Appointments are available on Friday, Oct. 10 from 12-4:30 p.m. and Saturday, Oct. 11 from 8-11:30 a.m.



Priority:

Empowering Exemplary Educators & Staff

Supportive Work Environment

Foster a **culture of collaboration, respect, and continuous growth** by providing the support and resources necessary for staff to thrive.

ACTION STEP UPDATE:

Expand and develop partnerships with post-secondary universities

- Fall 2025
 - University of Missouri – Kansas City
 - Missouri State University
 - Northwest Missouri State University
 - University of Kansas
 - Kansas State University
 - Pittsburg State University
 - University of Nebraska – Lincoln
 - Emporia State University
 - Fort Hays State University
 - MidAmerican Nazarene University
 - University of Nebraska – Kearney

BLUE VALLEY SCHOOLS

QUESTIONS?

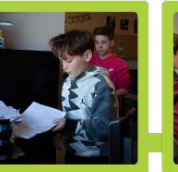



2025

DESIGN AND CONSTRUCTION REPORT

2024-25 Projects

Summer Painting – All Buildings

Gym Floor Refinishing – ABM, BVH, BVW

Full Interior Paint – BRE, LMS, BVNW, TCE

PAC and Little Theater Upgrades – BVH, BVN, BVW

FACS Remodels – BVH, BVN, BVW

Daktronics Video Boards – AntDAC, LamDAC, SwiDAC

Building IT Recabling – BVM, BVW

Band Room Addition – BVN

New Weight Room – BVN and BVNW

HVAC System Replacements – BVW and BVN

Tennis Court Renovation – BVN, BVNW

Building Furniture Replacement – BVW

Auxiliary Gymnasium and Storm Shelter Addition – BVW

Mobile Removal and Classroom Additions – CHE and LES

Multipurpose/Storm Shelter Addition – HES and PRM

Early Childhood Classroom Renovation – Hilltop

New Parking Lot/Drive Lane – LES/LMS, HMS, PSE

New Playground Surface – CHE and MTE

***97 capital improvement projects completed summer 2025**



2023

2024

2025

2026

2023												2024												2025												2026											
J	F	M	A	M	J	J	A	S	O	N	D	J	F	M	A	M	J	J	A	S	O	N	D	J	F	M	A	M	J	J	A	S	O	N	D	J	F	M	A	M	J	J	A	S	O	N	D

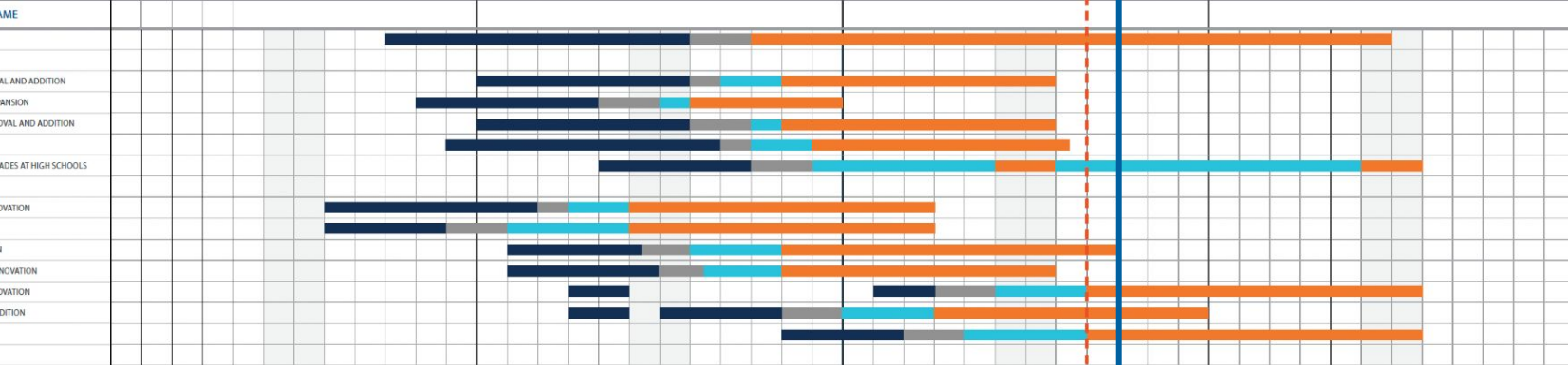

< Complete

LEGEND

- DESIGN
- BIDDING
- PLANNING
- CONSTRUCTION

2023

BOND UPDATE

“ These are more than just buildings, additions, and renovations... these are opportunities. Opportunities to enhance teaching and learning. Opportunities to foster community. Opportunities to grow and develop our students and staff into better versions of themselves. And we are forever thankful for these opportunities. ”



Blue Valley North High School Weight Room Addition & Wrestling Renovation

Complete: April 2025

“ Our students and athletes are taking pride in the new weight room. They enjoy being in there more and the amount of space and equipment is giving them a much better workout experience. They understand how fortunate we are and they are very excited and proud to come in every day to put in the work.”

“ The amount of space in the new weight room, along with new equipment, allows for more flexibility in our workouts/lessons and an overall greater workout experience for our students and athletes.”





Blue Valley West High School

Auxiliary Gym/Storm Shelter Addition

Complete: April 2025

““ Students in our leadership program said their ability to be involved in the design process and to share opinions on the overall look and feel of the space led to a design they feel really proud of.””

““ Having a larger auxiliary space that isn't connected to another gym or the track allows for uninterrupted activities and teaching within the PE department.””





Leawood Elementary School

Mobile Removal and Classroom Addition

Complete: August 2025



““ The addition gives us more room to learn, and we don't have to go to a trailer for Spanish or Gifted. It provides better lighting, bigger spaces, and helps us focus on learning.””

““ For five years, I taught in the trailer and being in the building now is MARVELOUS. No more cold weather, no more rain, and I don't have to worry about the safety of students going in and out.””



Cedar Hills Elementary School Mobile Removal and Classroom Addition

Complete: August 2025



“ This project has given CHE the opportunity for students to collaborate and connect outside of their classroom space to extend their academic skills, as well as their “soft” skills when working with others. ”

“ This new space gives us a comfy learning environment where we can collaborate with other students. It’s a quiet space that we can interact with other students and gain different perspectives around the work we are doing in our classroom. ”



Blue Valley Northwest High School
Weight Room Addition & Wrestling Renovation
Complete: August 2025

“ My favorite aspect is how the space combines functionality and inspiration. It’s filled with natural light, equipped with top-notch equipment, and intentionally designed to support both physical development and a strong sense of community and school pride. It’s a space where students can grow, lead, and push themselves to new levels, with staff there to teach, coach, and motivate them. ”





Blue Valley North High School
Performing Arts Addition
Complete: August 2025

“ Our new band room has provided a much larger space for rehearsals, more and better storage space, and a nicer environment for our students to feel proud of. It has allowed for having more equipment stowed away outside of the classroom so we have more room for students to function, and the acoustics are allowing for much better critique, analysis, and correction to enhance our future performances. ”





Blue Valley High, North and West High Schools CTE Renovations – FACS Rooms

Complete: August 2025

*BVNW, BVSU, & BV Academy Coming in 2026



“ Student response and excitement has been so enthusiastic. Both students who haven't taken a culinary class and those who took classes in the old room have been so excited for the new room. Working in the new room is so much better - there's more space, we can follow industry procedures to give students the experience of what the professional culinary world is like, plus the kitchens are so much easier to keep clean! ”



Harmony Middle School

Multipurpose Storm Shelter Addition

Anticipated Completion: October 2025



““ The multipurpose addition will provide exciting opportunities for students, staff, and our community as well as serve as a new and improved severe weather shelter for our school. ””

““ I am happy that I won't have to have morning basketball practice because of the new gym since there is an extra basketball court now. ””

““ I am excited to practice band in the new space when we split up into our different instruments. ””



Pleasant Ridge Middle School

Multipurpose Storm Shelter Addition

Anticipated Completion: January 2026

“ This investment will make the school a true gathering place for the community by allowing PRMS to host additional assemblies, musical concerts, sports events/practices, and youth leagues. It will also provide the students a safe, modern space to move, grow, and stay healthy. ”

“ I am a seventh grader, but next year when I play eighth grade basketball, it will be very helpful to have another gym for more space. It will be a lot more helpful for PE also because there will be so much more space when we have 70 kids in one class. Thank you so much. ”





Wolf Springs Middle School

Anticipated Completion: June 2026

Opening: August 2026



“ Wolf Springs Middle School will bring the excitement of building a vibrant new school community from the ground up—giving students the opportunity to shape new traditions and school culture while providing families in the growing Blue Valley Southwest area with access to another outstanding educational experience. I can’t wait to welcome all our new Coyotes to the pack. ”

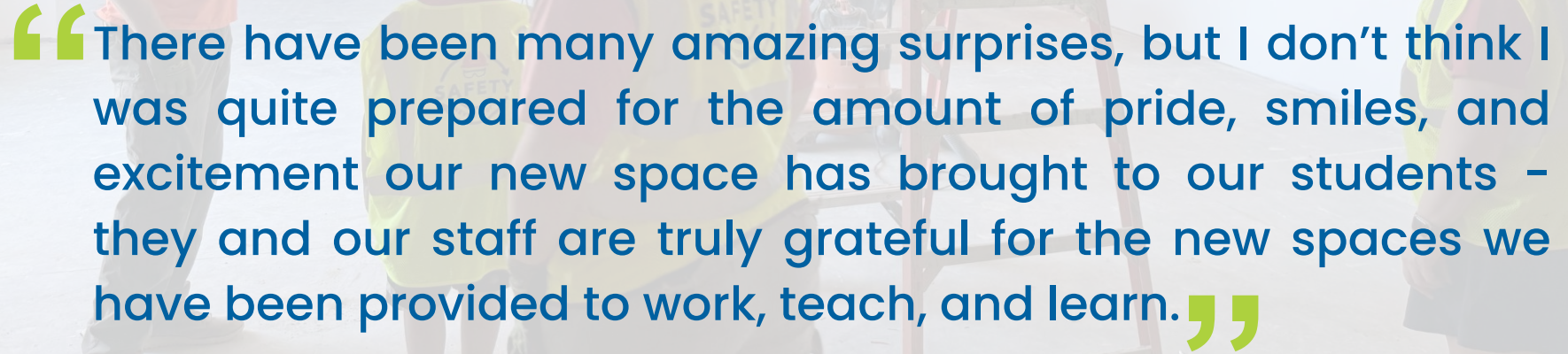

“There have been many amazing surprises, but I don't think I was quite prepared for the amount of pride, smiles, and excitement our new space has brought to our students - they and our staff are truly grateful for the new spaces we have been provided to work, teach, and learn.”

Thank you



Policy: 6610

Section: 6000 Personnel

Temporary and Personal Illness Leaves

Administrators

The administrator's immediate supervisor may approve a request from an administrator for temporary leave and/or personal illness leave after considering these factors:

- a. The purpose for which the leave is requested;
- b. The length of the requested leave;
- c. Whether the request is in compliance with Board policies;
- d. Whether the absence of the administrator from employment duties will have a detrimental impact on operations in the District; and
- e. The best interests of the District.

Requests for temporary and personal illness leaves shall be submitted in the manner prescribed by the Human Resources Department.

Temporary Leave

Administrators are eligible to receive up to 20 days of paid temporary leave from their employment duties for reasonable and necessary purposes each fiscal year. Temporary leave shall not accumulate from year to year. The District shall not provide compensation for unused temporary leave.

Administrators may use temporary leave for the following reasons:

- a. Illness of a spouse, son, daughter, mother, father, brother, sister, or those same members of spouse's family;
- b. Bereavement: In the event of death within the employee's immediate family, the employee may use bereavement leave.
 1. Upon death of the employee's spouse, son, daughter, mother, father, sibling, or upon loss of pregnancy, up to five (5) days of such bereavement leave may be used and shall not be deducted from accumulated temporary leave.
 2. Upon death of the employee's father-in-law, mother-in-law, son-in-law, daughter-in-law, brother-in-law, sister-in-law, grandparent, grandchild, aunt, uncle, niece, nephew, cousin, resident of the employee household, or upon the loss of an employee's child's pregnancy, up to three (3) days of such bereavement leave may be used and shall not be deducted from accumulated temporary leave. Up to two (2) additional days of bereavement leave may be requested and shall be deducted from accumulated temporary leave.
 3. Additional days may be granted by the Superintendent due to special circumstances.
- c. The birth/adoption of a grandchild; an employee may use up to five (5) consecutive days of his/her temporary leave upon the birth of a grandchild. This leave may be taken within four (4) weeks of the event. The total number of days used may not exceed five (5) school days.
- d. Attendance at a funeral;

- e. Observance of a denominational religious holiday;
- f. Personal business (limited to business that cannot be conducted outside of normal business hours - typically 8 a.m. to 4:30 p.m. Monday through Friday); or
- g. Appearance in a court of law as a litigant or witness pursuant to a subpoena.

Administrators may not use temporary leave for the following purposes:

- a. Interviewing for other employment positions;
- b. Vacation;
- c. Personal business during the first or last week of school; or
- d. Personal business on the day prior to or following any school holiday.

An administrator's temporary leave shall not be charged against the 45 days of personal illness leave available during each 12-month period.

Personal Illness Leave

Administrative employees are eligible to receive up to 45 days of paid personal illness leave from their employment duties for reasonable and necessary purposes during each 12-month period. Personal illness leave shall not accumulate from year to year. The District shall not provide compensation for unused personal illness leave.

Administrators may use personal illness for the following reasons:

- a. Any illness or injury to the administrator;
- b. An administrator's disability due to prenatal care;
- c. Birth of a child;
- d. Recuperation following delivery of an infant; or
- e. Adoption.

An administrator's personal illness leave shall not be charged against the 20 days of temporary leave available each fiscal year.

An administrator whose personal illness leave extends beyond five consecutive work days may be required to submit to the Human Resources Department a written request for personal illness leave accompanied by a physician's written statement. If requested, the physician's written statement shall describe the nature of the illness or incapacitation and verify the employee's ability to return to duties. The District shall reserve the right to delay an employee's return to work until appropriate certification is provided to and the Human Resource Department gives approval.

If the need for leave is due to personal illness or injury that precludes an administrator from performing essential job duties for a period of 45 days or longer, benefits may be available through a long-term disability plan provided through the District. In such cases, the administrator should contact the Human Resources Department as soon as reasonably possible to coordinate the application process for long-term disability benefits.

Leave for any purpose not addressed by this policy must be requested in writing, with approval given by the Superintendent or his or her designee.

An administrator must report any absence or anticipated absence from work to his or her immediate supervisor or another designated person prior to the start of the school day.

Any leave taken by an administrator must be recorded in the manner specified by the District. The District shall reserve the right to require additional documentation to determine eligibility for leave. Failure to provide appropriate documentation may result in a suspension of pay until such documentation is provided to and approved by the Human Resources Department.

The District shall reserve the right to refuse to return an administrator to work if it is deemed by the District that such action poses potential harm or hardship to the employee, other employees, and/or students.

Unusual circumstances may occur that necessitate modification of leave as defined in this policy. Based upon written appeal, approval of leave modification may be granted by the Superintendent or his or her designee. A second appeal may be made to the Superintendent or his or her designee.

Other benefit programs, policies, and/or procedures may coordinate with an administrator's temporary leave or personal illness leave. Information relating to these plans, programs, policies, and procedures shall be provided in administrative guidelines.

Classified Personnel

This policy shall apply to all classified employees of the District. It shall not apply to substitute or temporary employees, nor shall it apply to any employee whose individual employment agreement contains specific terms concerning temporary leave.

Temporary Leave

Each classified employee shall accumulate temporary leave at the rate of one-half of their average daily hours per pay period (semi-monthly). The calculation of an employee's average daily hours is based on the employee's weekly hours divided by 5 days. Temporary leave may be accumulated without limit.

Upon termination of employment with the District, classified employees shall forfeit any accumulated temporary leave. The District shall have no obligation to compensate a classified employee for any unused or accumulated temporary leave, except as a death or KPERS retirement benefit for an employee with 10 years of service.

If a classified employee has accumulated temporary leave and is entitled under this policy to use that temporary leave, such employee shall receive full pay for any period of absence from employment duties until his or her accumulated temporary leave is exhausted. A classified employee for the following reasons may use accumulated temporary leave:

- Personal illness, including disability due to prenatal care, birth of a child, and recuperation following delivery of a child;
- Illness of the classified employee's spouse, son, daughter, mother, father, brother, sister, or those same members of the classified employee's spouse's family;
- The birth/adoption of a grandchild; an employee may use up to five (5) consecutive days of his/her temporary leave upon the birth/adoption of a grandchild. This leave may be taken within ~~four (4) weeks~~ the first year following the event. The total number of days used may not exceed five (5) school days. Grandparent leave may not be used consecutively with personal leave. Any exceptions to the grandparent leave stipulations must be approved by the Director of Human Resources/Classified.
- Bereavement: In the event of death within the employee's immediate family, the employee may use bereavement leave.
 - Upon death of the employee's spouse, son, daughter, mother, father, sibling, father-in-law, mother-in-law, son-in-law, daughter-in-law, brother-in-law, sister-in-law, grandparent, grandchild, aunt, uncle, niece, nephew, cousin, resident of the employee's household, or upon the loss of pregnancy, or loss of an employee's child's pregnancy up to five (5) days of such bereavement leave may be used and shall not be deducted from accumulated temporary leave.
 - ~~○ Upon death of the employee's father-in-law, mother-in-law, son-in-law, daughter-in-law, brother-in-law, sister-in-law, grandparent, grandchild, aunt, uncle, niece, nephew, cousin, resident of the employee's household, or upon the loss of an employee's child's pregnancy, up to three (3) days of such bereavement leave may be used and shall not be deducted from accumulated temporary leave. Up to two (2) additional days of bereavement leave may be requested and shall be deducted from accumulated temporary leave.~~
 - Additional days may be granted by the Superintendent due to special circumstances.
- Attendance at a funeral;
- Observance of a denominational religious holiday;
- Appearance in a court of law as a litigant or witness pursuant to a subpoena; and
- Personal leave days. Personal leave days shall be deducted from the employee's accrued temporary leave. Personal leave days not utilized during one school calendar year may not be carried over to a the following year. Employees shall submit requests for personal leave to their building principal or department administrator at least 5 days in advance of the leave. Approval of the building principal or department administrator is required. A classified employee may use 5 up to fourteen (14) days of temporary leave, five (5) days of which may be consecutive, for a personal reason each school calendar year

Personal leave shall not be used during the first or last week of the school schedule.

If a classified employee desires use of a personal day during the first or last week of school due to an emergency condition or extraordinary circumstance, the request should be submitted in writing to the Director of Human Resources/Classified for consideration and approval.

Temporary leave may not be used for interviewing for other employment positions or for vacations.

Temporary leave hours shall be paid in accordance with the pay period provided the employee has returned to work or has been placed on an approved leave of absence. Payment for temporary leave hours may be delayed if an employee has not returned to work or has not been placed on an approved leave of absence.

Classified employees shall immediately report any absence or anticipated absence from work to the principal and/or supervisor in the manner indicated by the District. Applications for temporary leave shall be prepared on forms provided by the Human Resources Department and shall contain all information necessary to determine eligibility for temporary leave. Any classified employee who is absent from employment duties because of personal injury or who is absent from employment duties for a period of more than one week due to personal illness will be required to present a completed District's Return to Work – Medical Certification Form (available on the District's Web site or through the Benefits Department) to the Benefits Department. This form must be completed prior to the employee returning to work, even if no work restrictions apply. If work restrictions apply, then the Blue Valley Benefits Department will work with the appropriate supervisor and/or Human Resources Department to determine whether or not the work restrictions can be accommodated. If work restrictions cannot be accommodated, the employee will be notified and will not be able to return to work until such time as the physician releases the employee from the work restrictions as documented on the District's Return to Work – Medical Certification Form. The employee is responsible for paying any cost incurred in conjunction with the completion of this form.

A classified employee may be required to submit to a physical and/or mental examination prior to returning to work. The District shall pay any cost incurred in connection with a physician's statement. If as the result of all information available, the Human Resources Department determines that a classified employee is physically or mentally unable to perform his or her employment duties with reasonable accommodation, or if the Human Resources Department determines that the employee's condition is such that a return to work could be hazardous to the employee or other employees of the District, then the Human Resources Department may postpone the employee's return to work until such time as the employee's physical and/or mental condition no longer poses a hazard to such employee, other employees, or students of the District.

Upon the death or KPERS retirement of a classified employee with at least 10 years of service in the District, any accumulated temporary leave shall be reimbursed according to the following formula:

Years of service in the District x 4 percent x the current daily rate of a classified substitute pay x the accumulated unused temporary leave days.

The maximum number of temporary leave days for which compensation may be granted shall be ~~425~~ 145.

Temporary leave hours (excluding personal leave hours) shall not be counted as time worked for the purposes of computing overtime.

Temporary leave hours cannot be used to extend an employee's length of service with the District.

B.O.E. Amended 13 Aug 1979
B.O.E. Adopted 13 Feb 1989
B.O.E. Adopted 09 Apr 1990
B.O.E. Amended 14 Oct 1991
B.O.E. Amended 13 Dec 1993
B.O.E. Amended 13 Apr 1994
B.O.E. Amended 10 Feb 1997
B.O.E. Adopted 12 Oct 1998
B.O.E. Amended 10 Jul 2000
B.O.E. Amended 14 May 2001
B.O.E. Amended 08 Sep 2003
B.O.E. Amended 13 Jun 2005
B.O.E. Amended 08 Oct 2007
B.O.E. Amended 11 Jan 2010
B.O.E. Amended 12 July 2010
B.O.E. Amended 08 Aug 2011
B.O.E. Amended 11 Jun 2012
B.O.E. Amended 11 Sep 2017
B.O.E. Amended 10 Dec 2018
B.O.E. Amended 11 Sept 2023

Adoption Date: **February 13, 1989**
Last Revised: **September 11, 2023**
Last Reviewed Dates: **October 13, 2025**
Prior Revised Dates: **12/10/2018**

**EXCERPT OF MINUTES OF A MEETING
OF THE BOARD OF EDUCATION OF
UNIFIED SCHOOL DISTRICT NO. 229, JOHNSON COUNTY, KANSAS (BLUE VALLEY)
HELD ON OCTOBER 13, 2025**

The Board of Education (the "Governing Body") met in regular session at the usual meeting place in the District, at 5:30 p.m., the following members being present and participating, to-wit:

Present: _____.

Absent: _____.

The President declared that a quorum was present and called the meeting to order.

* * * * *

(Other Proceedings)

The matter of providing for the offering for sale of general obligation bonds came on for consideration and was discussed.

Board Member _____ presented and moved the adoption of a Resolution entitled:

A RESOLUTION AUTHORIZING THE PUBLIC SALE OF GENERAL OBLIGATION BONDS OF UNIFIED SCHOOL DISTRICT NO. 229, JOHNSON COUNTY, KANSAS (BLUE VALLEY), AND CERTAIN OTHER ACTIONS RELATING TO THE BONDS.

Board Member _____ seconded the motion to adopt the Resolution. The Resolution was read and considered, and, the question being put to a roll call vote, the vote thereon was as follows:

Yea: _____.

Nay: _____.

The President declared the Resolution duly adopted by the Governing Body.

* * * * *

(Other Proceedings)

[Balance of this page intentionally left blank]

CERTIFICATE

I hereby certify that the foregoing Excerpt of Minutes is a true and correct excerpt of the proceedings of the Governing Body of Unified School District No. 229, Johnson County, Kansas (Blue Valley), held on the date stated therein, and that the official minutes of such proceedings are on file in my office.

(SEAL)

Clerk

A RESOLUTION AUTHORIZING THE PUBLIC SALE OF GENERAL OBLIGATION BONDS OF UNIFIED SCHOOL DISTRICT NO. 229, JOHNSON COUNTY, KANSAS (BLUE VALLEY), AND CERTAIN OTHER ACTIONS RELATING TO THE BONDS.

WHEREAS, pursuant to proceedings duly had, an election was held in Unified School District No. 229, Johnson County, Kansas (Blue Valley) (the “District”), on January 31, 2023, on the proposition to issue general obligation bonds in an amount not to exceed \$251,250,000 to purchase and improve sites and to acquire, construct, equip, furnish, repair, remodel and make additions to buildings used for school district purposes, including acquisition of new and upgraded computer and communications technology, and all necessary appurtenances thereto, and to pay fees and expenses incidental thereto (collectively, the “Improvements”); all pursuant to the provisions of K.S.A. 10-101 *et seq.*, K.S.A. 25-431 *et seq.*, K.S.A. 25-2018(f), and K.S.A. 72-5457; and

WHEREAS, said proposition was approved by a majority of the voters of the District voting thereon and the District is authorized to proceed with the sale and issuance of the bonds authorized at said election; and

WHEREAS, the District has previously issued \$150,000,000 of the bonds approved at such election; and

WHEREAS, the Board of Education (the “Governing Body”) of the District wishes to proceed with plans for the sale and issuance of the remaining \$101,250,000 principal amount of bonds approved at said election to finance a portion of the costs of the Improvements; and

WHEREAS, the District has previously issued and has outstanding general obligation bonds, of which all or a portion of certain maturities described below are being considered for refunding (collectively, the “Refunded Bonds”):

<u>Description</u>	<u>Series</u>	<u>Dated Date</u>	<u>Years</u>	<u>Amount</u>
General Obligation School Bonds	2015-A	October 1, 2015	2026-2034	43,850,000
General Obligation Refunding Bonds	2015-B	October 1, 2015	2026-2027	12,255,000

; and

WHEREAS, current market conditions have made it possible to undertake a refunding plan for the Refunded Bonds that will achieve interest cost savings and provide a more economical and efficient program for the retirement of the indebtedness represented by the Refunded Bonds, and it has become desirable and in the best interests of the District and its inhabitants to proceed with plans for refunding all or a portion of the Refunded Bonds; and

WHEREAS, the Governing Body has selected the firm of Stifel, Nicolaus & Company, Incorporated, Kansas City, Missouri (the “Municipal Advisor”), as municipal advisor for one or more series of general obligation bonds of the District to be issued in order to provide funds to finance the Improvements and refund all or a portion of the Refunded Bonds; and

WHEREAS, the District desires to authorize the Municipal Advisor to proceed with the offering for sale of said general obligation bonds and related activities; and

WHEREAS, one of the duties and responsibilities of the District is to prepare and distribute a preliminary official statement relating to said general obligation bonds; and

WHEREAS, the District desires to authorize the Municipal Advisor and Gilmore & Bell, P.C., Kansas City, Missouri, the District's bond counsel ("Bond Counsel"), in conjunction with appropriate District officers, to proceed with the preparation and distribution of a preliminary official statement and notice of bond sale and to authorize the distribution thereof and all other preliminary action necessary to sell said general obligation bonds.

NOW, THEREFORE, BE IT RESOLVED BY THE GOVERNING BODY OF UNIFIED SCHOOL DISTRICT NO. 229, JOHNSON COUNTY, KANSAS (BLUE VALLEY), AS FOLLOWS:

Section 1. There is hereby authorized to be offered for sale one or more series of the District's general obligation bonds to finance a portion of the costs of the Improvements and/or, at a level of savings acceptable to officers and representatives of the District, refunding all or a portion of the Refunded Bonds (collectively, the "Bonds") described in the Notice of Bond Sale, which shall be prepared by Bond Counsel in conjunction with the Municipal Advisor and appropriate officers of the District (the "Notice of Bond Sale"). All proposals for the purchase of the Bonds shall be delivered to the Governing Body at its meeting to be held on the sale date referenced in the Notice of Bond Sale, at which meeting the Governing Body shall review such bids and award the sale of the Bonds or reject all proposals.

Section 2. The President, Clerk and other appropriate officers of the District, in conjunction with the Municipal Advisor and Bond Counsel, are hereby authorized to cause to be prepared a Preliminary Official Statement relating to the Bonds (the "Preliminary Official Statement"), and such officials and other representatives of the District are hereby authorized to use such document in connection with the sale of the Bonds.

Section 3. The Clerk and other appropriate officials of the District, in conjunction with the Municipal Advisor and Bond Counsel, are hereby authorized and directed to give notice of said bond sale by publishing a summary of the Notice of Bond Sale not less than 6 days before the date of the bond sale in a newspaper of general circulation in Johnson County, Kansas, and the *Kansas Register* and by distributing copies of the Notice of Bond Sale and Preliminary Official Statement to prospective purchasers of the Bonds. Proposals for the purchase of the Bonds shall be submitted upon the terms and conditions set forth in the Notice of Bond Sale and awarded or rejected in the manner set forth in the Notice of Bond Sale.

Section 4. For the purpose of enabling the purchaser of the Bonds (the "Purchaser") to comply with the requirements of Rule 15c2-12 of the Securities and Exchange Commission (the "Rule"), the President, Clerk or other appropriate officers of the District are hereby authorized: (a) to approve the form of the Preliminary Official Statement and to execute the "Certificate Deeming Preliminary Official Statement Final" in substantially the form attached hereto as *Exhibit A* as approval of the Preliminary Official Statement, such official's signature thereon being conclusive evidence of such official's and the District's approval thereof; (b) covenant to provide continuous secondary market disclosure by annually transmitting certain financial information and operating data and other information necessary to comply with the Rule to the Municipal Securities Rulemaking Board; and (c) take such other actions or execute such other documents as such officers in their reasonable judgment deem necessary to enable the Purchaser to comply with the requirement of the Rule.

Section 5. The District agrees to provide to the Purchaser within seven business days of the date of the sale of Bonds or within sufficient time to accompany any confirmation that requests payment from any customer of the Purchaser, whichever is earlier, sufficient copies of the final Official Statement

to enable the Purchaser to comply with the requirements of the Rule and with the requirements of Rule G-32 of the Municipal Securities Rulemaking Board.

Section 6. The President, Clerk and the other officers and representatives of the District, the Municipal Advisor and Bond Counsel, are hereby authorized and directed to take such other action as may be necessary to: (a) carry out the sale of the Bonds; (b) provide for notice of redemption of the Refunded Bonds; (c) purchase or subscribe for the securities to be deposited in the escrow for the Refunded Bonds; and (d) take necessary steps to provide for the redemption of the Refunded Bonds, including transmitting currently budgeted funds to the paying agent for the Refunded Bonds in advance of the scheduled payment date.

Section 7. The transactions described in this Resolution may be conducted, and documents related to the Bonds may be sent, received, executed, and stored, by electronic means or transmissions. Copies, telecopies, electronic files and other reproductions of original executed documents (or documents executed by electronic means or transmissions) shall be deemed to be authentic and valid counterparts of such documents for all purposes, including the filing of any claim, action or suit in the appropriate court of law.

Section 8. This Resolution shall be in full force and effect from and after its adoption.

[Balance of page intentionally left blank]

ADOPTED by the Governing Body on October 13, 2025.

(SEAL)

President

ATTEST:

Clerk

EXHIBIT A

**CERTIFICATE DEEMING
PRELIMINARY OFFICIAL STATEMENT FINAL**

October __, 2025

To: _____

Re: Unified School District No. 229, Johnson County, Kansas (Blue Valley), General
Obligation [School][Refunding] Bonds, Series _____

The undersigned is the duly acting Chief Financial Officer of Unified School District No. 229, Johnson County, Kansas (Blue Valley) (the “District”) and is authorized to deliver this Certificate to the purchaser(s) (the “Purchaser”) of the above-referenced bonds (the “Bonds”) on behalf of the District. The District has previously caused to be delivered to the Purchaser copies of the Preliminary Official Statement (the “Preliminary Official Statement”) relating to the Bonds.

For the purpose of enabling the Purchaser to comply with the requirements of Rule 15c2-12(b)(1) of the Securities and Exchange Commission (the “Rule”), the District hereby deems the information regarding the District contained in the Preliminary Official Statement to be final as of its date, except for the omission of such information as is permitted by the Rule, such as offering prices, interest rates, selling compensation, aggregate principal amount, principal per maturity, delivery dates, ratings, identity of the underwriters and other terms of the Bonds depending on such matters.

**UNIFIED SCHOOL DISTRICT NO. 229, JOHNSON
COUNTY, KANSAS (BLUE VALLEY)**

By: _____
Title: Chief Financial Officer



Human Resources Report to the Board of Education

Addendum

October 13, 2025

Administration recommends approval of the following actions:

RESIGNATIONS

<u>Name</u>	<u>Location</u>	<u>Position</u>	<u>Effective</u>
WIER, EUGENE PATRICK	BLUE VALLEY NORTH HIGH SCHOOL	TEACHER-PHYSICAL EDUCATION	12/31/2025



Human Resources Report to the Board of Education

Addendum

October 13, 2025

Administration recommends approval of the following actions:

SUPPLEMENTALS

<u>Name</u>	<u>Location</u>	<u>Position</u>	<u>Effective</u>
ADAIR, MARK JEFFREY	BLUE VALLEY MIDDLE SCHOOL	DIRECTOR-JAZZ BAND	08/06/2025
ADAIR, MARK JEFFREY	DISTRICT WIDE	LIMITED SUPPLY 3 OF 3	09/16/2025
ADAMS, SHANNON LEANN	BLUE VALLEY WEST HIGH SCHOOL	ADDL TEACHING PLAN-2ND SEM	01/05/2026
AGUILERA, ANDRES	BLUE VALLEY NORTH HIGH SCHOOL	ASST DIRECTOR-FALL PLAY	08/16/2025
AGUILERA, ANDRES	BLUE VALLEY NORTH HIGH SCHOOL	ASST DIRECTOR-WINTER MUSICAL	11/16/2025
ALDERMAN, GEORGE CURTIS	HARMONY MIDDLE SCHOOL	ASST COACH-BOYS BASKETBALL	11/16/2025
ALDERMAN, GEORGE CURTIS	HARMONY MIDDLE SCHOOL	ASST DIRECTOR-SPRING MUSICAL	11/16/2025
ALEXANDER, CARISSA N	OXFORD MIDDLE SCHOOL	SUPERVISOR-1/2 HR LUNCHROOM	08/06/2025
ALEXANDER, TARA MARIE	DISTRICT WIDE	LIMITED SUPPLY 2 OF 3	09/16/2025
ALLEN, BRIDGET ELAINE	BLUE VALLEY WEST HIGH SCHOOL	DEPARTMENT CHAIR-SPED	08/06/2025
ALLEN, CLAIRE A	DISTRICT WIDE	DRUG & ALCOHOL COORDINATOR	09/01/2025
ALLEN, CLAIRE A	LAKEWOOD MIDDLE SCHOOL	SUPERVISOR-1/2 HR LUNCHROOM	08/06/2025
ALLEN, LAUREN ELIZABETH	AUBRY BEND MIDDLE SCHOOL	SUPERVISOR-1/2 HR LUNCHROOM	08/06/2025
ALLPHIN, CIERRA LYNNE	BLUE VALLEY WEST HIGH SCHOOL	ASST COACH-TRACK	03/01/2026
ALLPHIN, RANSOM MCKAY	BLUE VALLEY WEST HIGH SCHOOL	ASST COACH-TRACK	03/01/2026
AMPADI RAMACHANDRAN, REMYA	LAKEWOOD MIDDLE SCHOOL	ASST SPONSOR-SCIENCE OLYMPIAD	09/23/2025
ANDERSON, CAROLINE KAY	DISTRICT WIDE	NATIONAL BOARD CERTIFICATION	08/06/2025
ANDERSON, JENNIFER KATHLEEN	DISTRICT WIDE	LIMITED SUPPLY 2 OF 3	09/16/2025
ANDREASEN, TRACEY LYNN	HARMONY MIDDLE SCHOOL	ASST DIRECTOR-SPRING MUSICAL	11/16/2025
ARBUCCI, LAUREN ASHLEY	BLUE VALLEY WEST HIGH SCHOOL	SUPERVISOR-LUNCHROOM	08/06/2025
ASHEN, JEFFREY S	BLUE VALLEY WEST HIGH SCHOOL	ADDL TEACHING PLAN-YEAR	08/06/2025
BABKIN, SARAH ELIZABETH	OXFORD MIDDLE SCHOOL	LEADERSHIP TEAM MEMBER	08/06/2025
BALINT, SARA A	BLUE VALLEY WEST HIGH SCHOOL	COORDINATOR-GRADE LEVEL	08/06/2025
BALL, JAMES ELVIN	HARMONY MIDDLE SCHOOL	ASST DIRECTOR-SPRING MUSICAL	11/16/2025
BALL, JULIE D	DISTRICT WIDE	DRUG & ALCOHOL COORDINATOR	09/01/2025
BALLEW, AARON JAMES	BLUE VALLEY SOUTHWEST HS	ADDL TEACHING PLAN-YEAR	08/06/2025
BANDRE, LISA	BLUE VALLEY WEST HIGH SCHOOL	ADDL TEACHING PLAN-YEAR	08/06/2025
BANE, LEAH MARY	DISTRICT WIDE	LIMITED SUPPLY 3 OF 3	09/16/2025
BANKS, ANGELA LAUREN	DISTRICT WIDE	LIMITED SUPPLY 3 OF 3	09/16/2025
BARILLEAUX, MARGARET ELIZABETH	DISTRICT WIDE	LIMITED SUPPLY 3 OF 3	09/16/2025
BARNES, DUSTIN LYNN	BLUE VALLEY SOUTHWEST HS	SUPERVISOR-LUNCHROOM	08/06/2025
BARNES, TARA MICHEL	DISTRICT WIDE	COORDINATOR-ART	08/06/2025
BARNHART, HEATHER ROSE	BLUE VALLEY WEST HIGH SCHOOL	DEPARTMENT CHAIR-ADVISORY	08/06/2025
BASOM, AMBER NICHOLE	DISTRICT WIDE	COORDINATOR-COUNSELING	08/06/2025
BASSHAM, CALEB	HARMONY MIDDLE SCHOOL	ASST DIRECTOR-SPRING MUSICAL	11/16/2025
BAUCOM, KELLI E	BLUE VALLEY SOUTHWEST HS	COORDINATOR-GRADE LEVEL	08/06/2025
BAUMAN, LISA ANN	DISTRICT WIDE	NATIONAL BOARD CERTIFICATION	08/06/2025
BAUMGART, LAUREN	DISTRICT WIDE	LIMITED SUPPLY 3 OF 3	09/16/2025
BAUS, KAREN ANN	DISTRICT WIDE	LIMITED SUPPLY 2 OF 3	09/16/2025
BELL, ELIZABETH JORDAN	DISTRICT WIDE	LIMITED SUPPLY 2 OF 3	09/16/2025



Human Resources Report to the Board of Education

Addendum

October 13, 2025

Administration recommends approval of the following actions:

BENSCHIEDT, LAURA LOUISE	CENTER FOR ADV PROF STUDIES	ADDL TEACHING RESPONSIBILITIES	08/06/2025
BENSCHIEDT, LAURA LOUISE	CENTER FOR ADV PROF STUDIES	CAPS BUSINESS PARTNERSHIP	08/06/2025
BENSCHIEDT, LAURA LOUISE	CENTER FOR ADV PROF STUDIES	CAPS STRAND LEADER	08/06/2025
BENSCHIEDT, LAURA LOUISE	DISTRICT WIDE	FACILITATOR-CURRICULUM TRAININ	08/06/2025
BENSCHIEDT, LAURA LOUISE	CENTER FOR ADV PROF STUDIES	HEAD SPONSOR-HOSA	08/06/2025
BERGEE, JILL A	DISTRICT WIDE	NATIONAL BOARD CERTIFICATION	08/06/2025
BERGERON, ALEC MICHEL	BLUE VALLEY WEST HIGH SCHOOL	ADDL TEACHING PLAN-YEAR	08/06/2025
BEYE, EMILY E	BLUE VALLEY MIDDLE SCHOOL	HEAD COACH-BOYS TRACK	03/01/2026
BIGELOW, ISABELLE MARIE	DISTRICT WIDE	LIMITED SUPPLY 3 OF 3	09/16/2025
BILLQUIST, LINDSAY ELIZABETH	LEAWOOD MIDDLE SCHOOL	SUPERVISOR-1/2 HR LUNCHROOM	08/06/2025
BIRNBAUM, CAROL ELLEN	DISTRICT WIDE	FACILITATOR-CURRICULUM TRAININ	08/06/2025
BISHOP, BRANDON E	BLUE VALLEY SOUTHWEST HS	ADDL TEACHING PLAN-YEAR	08/06/2025
BJORGO, LUKAS GENE	BLUE VALLEY SOUTHWEST HS	HEAD COACH-WRESTLING GIRLS	11/16/2025
BLACK, CARTER D	BLUE VALLEY WEST HIGH SCHOOL	ADDL TEACHING PLAN-YEAR	08/06/2025
BLACK, CARTER D	BLUE VALLEY WEST HIGH SCHOOL	COORDINATOR-GRADE LEVEL	08/06/2025
BLACK, CARTER D	DISTRICT WIDE	LIMITED SUPPLY 3 OF 3	09/16/2025
BLACKWELL, SHELLEY L	LEAWOOD ELEMENTARY	AD INTERN SUPERVISION DUTIES	08/06/2025
BOEHM, MEGHAN M	CENTER FOR ADV PROF STUDIES	ADDL TEACHING RESPONSIBILITIES	08/06/2025
BOEHM, MEGHAN M	CENTER FOR ADV PROF STUDIES	CAPS BUSINESS PARTNERSHIP	08/06/2025
BOGE, JULIA ANNE	CENTER FOR ADV PROF STUDIES	ADDL TEACHING RESPONSIBILITIES	08/06/2025
BOGE, JULIA ANNE	CENTER FOR ADV PROF STUDIES	CAPS BUSINESS PARTNERSHIP	08/06/2025
BOGE, JULIA ANNE	DISTRICT WIDE	FACILITATOR-CURRICULUM TRAININ	08/06/2025
BOLDRIDGE, CLAUDINE ELIZABETH	BLUE VALLEY NORTHWEST HS	8 EXTENDED DAYS-DEPT CHAIR	08/06/2025
BOLDRIDGE, CLAUDINE ELIZABETH	BLUE VALLEY NORTHWEST HS	DEPARTMENT CHAIR-SPED	08/06/2025
BOLLINGER, BRIAN ROBERT	HARMONY MIDDLE SCHOOL	SUPERVISOR-1/2 HR LUNCHROOM	08/06/2025
BOND, BENJAMIN KYLE	DISTRICT WIDE	COORDINATOR-PE	08/06/2025
BOOK, ANDREW JOHN	PLEASANT RIDGE MIDDLE SCHOOL	ADDL TEACHING RESPONSIBILITIES	08/06/2025
BOOS, MICHAEL TODD	BLUE VALLEY MIDDLE SCHOOL	ASST COACH-BOYS BASKETBALL	11/16/2025
BORCHER, MEGAN MICHELLE	DISTRICT WIDE	LIMITED SUPPLY 3 OF 3	09/16/2025
BORDONI, LILY SHAN	WOLF SPRINGS ELEMENTARY	ADDL TEACHING CI-YEAR	08/06/2025
BOX, BRIAN SAMUEL	BLUE VALLEY NORTH HIGH SCHOOL	DEPARTMENT CHAIR-PERFORM ARTS	08/06/2025
BRACHTENBACH, STEPHANIE NICOLE	DISTRICT WIDE	NATIONAL BOARD CERTIFICATION	08/06/2025
BREEDLOVE, JEFFREY MICHAEL	BLUE VALLEY NORTH HIGH SCHOOL	DEPARTMENT CHAIR-SOC SCIENCE	08/06/2025
BRIGGS, DAVID A	BLUE VALLEY HIGH SCHOOL	DEPARTMENT CHAIR-INDUST TECH	08/06/2025
BRIGGS, KEEGAN NICOLLE	DISTRICT WIDE	LIMITED SUPPLY 3 OF 3	09/16/2025
BRIODY, JILL M	DISTRICT WIDE	LIMITED SUPPLY 3 OF 3	09/16/2025
BRODERSEN, CHRISTOPHER GEORGE	OVERLAND TRAIL MIDDLE SCHOOL	ASST DIRECTOR-FALL MUSICAL	08/16/2025
BRODERSEN, CHRISTOPHER GEORGE	DISTRICT WIDE	FACILITATOR-CURRICULUM TRAININ	08/06/2025
BROWN, AMY JO	BLUE VALLEY WEST HIGH SCHOOL	DEPARTMENT CHAIR-COUNSELOR	08/06/2025
BROWN, PAUL B	BLUE VALLEY HIGH SCHOOL	DEPARTMENT CHAIR-PE	08/06/2025
BROWN, SARAH DOLENCE	BLUE VALLEY SOUTHWEST HS	DEPARTMENT CHAIR-MATH	08/06/2025
BRUCE, JUSTIN ALEXANDER	BLUE VALLEY MIDDLE SCHOOL	ASST COACH-BOYS BASKETBALL	11/16/2025
BRUCE, JUSTIN ALEXANDER	BLUE VALLEY MIDDLE SCHOOL	LEADERSHIP TEAM MEMBER	08/06/2025
BRUNER-LASISTER, HARMONY SAFFRON	DISTRICT WIDE	LIMITED SUPPLY 2 OF 3	09/16/2025



Human Resources Report to the Board of Education

Addendum

October 13, 2025

Administration recommends approval of the following actions:

BUCKNER, JEFFERY ALLEN	LAKESWOOD MIDDLE SCHOOL	SUPERVISOR-1/2 HR LUNCHROOM	08/06/2025
BUEHLER, GREGG ROWLAND	BLUE VALLEY SOUTHWEST HS	SUPERVISOR-LUNCHROOM	08/06/2025
BUEHLER, JENNIFER ALICIA	BLUE VALLEY WEST HIGH SCHOOL	DEPARTMENT CHAIR-SPED	08/06/2025
BURDICK, ANTHONY NAZIO	DISTRICT WIDE	FACILITATOR-CURRICULUM TRAININ	08/06/2025
BURGESS, TREVOR LEE	DISTRICT WIDE	DRUG & ALCOHOL COORDINATOR	09/01/2025
BUSHOUSE, KELLY ANNE	LAKESWOOD MIDDLE SCHOOL	ASST DIRECTOR-SPRING MUSICAL	03/01/2026
BUXTON, ASHLEY MARIE	DISTRICT WIDE	LIMITED SUPPLY 3 OF 3	09/16/2025
CAIN, RACHEL MAY	BLUE VALLEY NORTH HIGH SCHOOL	ASST DIRECTOR-WINTER MUSICAL	11/16/2025
CAIN, RACHEL MAY	BLUE VALLEY NORTH HIGH SCHOOL	DIRECTOR-WINTER MUSICAL	11/16/2025
CALLISON, KRISTIN GARNER	DISTRICT WIDE	COORDINATOR-PE	08/06/2025
CAMPBELL, ROBERT TODD	CENTER FOR ADV PROF STUDIES	ADDL TEACHING RESPONSIBILITIES	08/06/2025
CAMPBELL, ROBERT TODD	CENTER FOR ADV PROF STUDIES	CAPS BUSINESS PARTNERSHIP	08/06/2025
CARDOZO, SHERI ELISE	DISTRICT WIDE	LIMITED SUPPLY 3 OF 3	09/16/2025
CARENAS, SONIA MARIA	BLUE VALLEY NORTH HIGH SCHOOL	DEPARTMENT CHAIR-FOREIGN LNG	08/06/2025
CAREY, SOPHIA NICOLE	HARMONY MIDDLE SCHOOL	ASST DIRECTOR-SPRING MUSICAL	11/16/2025
CARPENTER, TERI RENEE	DISTRICT WIDE	LIMITED SUPPLY 3 OF 3	09/16/2025
CARR, ZACHARY BRENT	BLUE VALLEY NORTH HIGH SCHOOL	ASST COACH-BOYS BASKETBALL	11/16/2025
CARTER, EMILY ANNE	DISTRICT WIDE	LIMITED SUPPLY 3 OF 3	09/16/2025
CATANZARO, DANIEL M	BLUE VALLEY WEST HIGH SCHOOL	ADDL TEACHING PLAN-YEAR	08/06/2025
CATES, AMANDA GAYLE	DISTRICT WIDE	LIMITED SUPPLY 2 OF 3	09/16/2025
CHAUDHRY, HARRIS HAMEED	BLUE VALLEY SOUTHWEST HS	ASST COACH-DEBATE	10/01/2025
CHEN, RONALD CHING YUN	BLUE VALLEY NORTH HIGH SCHOOL	HEAD SPONSOR-SCIENCE OLYMPIAD	09/15/2025
CHENG, HSIAO CHING	WOLF SPRINGS ELEMENTARY	ADDL TEACHING CI-YEAR	08/06/2025
CHENG, YUAN	WOLF SPRINGS ELEMENTARY	ADDL TEACHING CI-YEAR	08/06/2025
CHEUNG, JENNY CHIEHNI	WOLF SPRINGS ELEMENTARY	ADDL TEACHING CI-YEAR	08/06/2025
CHRISTENSEN, MATTHEW CARY	BLUE VALLEY SOUTHWEST HS	DEPARTMENT CHAIR-SOC SCIENCE	08/06/2025
CHRISTENSEN, MATTHEW CARY	BLUE VALLEY SOUTHWEST HS	SUPERVISOR-LUNCHROOM	08/06/2025
CHRISTIANSEN, JULIE REBECCA	BLUE VALLEY MIDDLE SCHOOL	SUPERVISOR-1/2 HR LUNCHROOM	08/06/2025
CHUGG, JEREMY ALLAN	BLUE VALLEY NORTH HIGH SCHOOL	ADDL TEACHING PLAN-1ST SEM	08/06/2025
CHUSHUK, RACHEL SUZANNE	BLUE VALLEY SOUTHWEST HS	DEPARTMENT CHAIR-LIBRARY	08/06/2025
CLARK, KAITLYN N	OVERLAND TRAIL MIDDLE SCHOOL	ASST DIRECTOR-FALL MUSICAL	08/16/2025
CLARK, KAITLYN N	OVERLAND TRAIL MIDDLE SCHOOL	TEAM LEADER-OTHER RESP	08/06/2025
CLARK, KALI MAE	CENTER FOR ADV PROF STUDIES	SPONSOR-FIRST ROBOTICS	08/16/2025
CLAUSEN, MELODY J	BLUE VALLEY SOUTHWEST HS	DEPARTMENT CHAIR-SCIENCE	08/06/2025
COBLE, EMMA LOUISE	DISTRICT WIDE	LIMITED SUPPLY 2 OF 3	09/16/2025
COCHERL, ANNA MARIE	HARMONY MIDDLE SCHOOL	ASST DIRECTOR-SPRING MUSICAL	11/16/2025
COCUMELLI, BRITT P	DISTRICT WIDE	LIMITED SUPPLY 3 OF 3	09/16/2025
COLLINS, CAMERON SLADE	OXFORD MIDDLE SCHOOL	SPONSOR-STUDENT COUNCIL	08/06/2025
COLLINS, CAMERON SLADE	OXFORD MIDDLE SCHOOL	SUPERVISOR-1/2 HR LUNCHROOM	08/06/2025
COLLINS, TIMOTHY HOWARD	BLUE VALLEY NORTHWEST HS	SPONSOR-NATL CURRIC HONOR SOC	08/06/2025
CONLEY, KYLE BOYD	BLUE VALLEY WEST HIGH SCHOOL	ADDL TEACHING SUPV-YEAR	08/06/2025
CONRAD, LAUREL MARIE	DISTRICT WIDE	BCBA CERTIFICATION	08/06/2025
CONSTANCE, LISA M	DISTRICT WIDE	LIMITED SUPPLY 3 OF 3	09/16/2025
COOK, BRADLEY ALAN	AUBRY BEND MIDDLE SCHOOL	SUPERVISOR-1/2 HR LUNCHROOM	08/06/2025



Human Resources Report to the Board of Education

Addendum

October 13, 2025

Administration recommends approval of the following actions:

COOK, LORI MARIE	HARMONY MIDDLE SCHOOL	LEADERSHIP TEAM MEMBER	08/06/2025
COOK, RACHEL ELIZABETH	BLUE VALLEY SOUTHWEST HS	ADDL TEACHING SUPV-YEAR	08/06/2025
COOK, RACHEL ELIZABETH	BLUE VALLEY SOUTHWEST HS	SUPERVISOR-LUNCHROOM	08/06/2025
COOPER, LINDA L	BLUE VALLEY MIDDLE SCHOOL	ASST COACH-GIRLS BASKETBALL	11/16/2025
COPELAND, ELIZABETH NASH	LEAWOOD MIDDLE SCHOOL	ADDL TEACHING RESPONSIBILITIES	08/06/2025
CORDELL, MICHAEL DAVID	LEAWOOD MIDDLE SCHOOL	SUPERVISOR-1/2 HR LUNCHROOM	08/06/2025
CORDES, SHANNON LEE ANDREW	BLUE VALLEY NORTH HIGH SCHOOL	ASST COACH-BOYS BASKETBALL	11/16/2025
CORNELIUS, ABIGAIL M	BLUE VALLEY NORTH HIGH SCHOOL	COORDINATOR-BUILDING ADVISORY	08/06/2025
CORNELIUS, ABIGAIL M	BLUE VALLEY NORTH HIGH SCHOOL	DEPARTMENT CHAIR-LIBRARY	08/06/2025
CORNELIUS, ABIGAIL M	DISTRICT WIDE	NATIONAL BOARD CERTIFICATION	08/06/2025
CRANE, ALISON DALE	CENTER FOR ADV PROF STUDIES	ADDL TEACHING RESPONSIBILITIES	08/06/2025
CRANE, ALISON DALE	CENTER FOR ADV PROF STUDIES	CAPS BUSINESS PARTNERSHIP	08/06/2025
CRANE, ALISON DALE	DISTRICT WIDE	COORDINATOR-ART	08/06/2025
CRANE, ALISON DALE	DISTRICT WIDE	FACILITATOR-CURRICULUM TRAININ	08/06/2025
CRAVEN, KAITLYN MARIE	DISTRICT WIDE	LIMITED SUPPLY 3 OF 3	09/16/2025
DAIGLE, JOHN PAUL	BLUE VALLEY NORTH HIGH SCHOOL	DEPARTMENT CHAIR-SPED	08/06/2025
DALTON, REBECCA A	BLUE VALLEY NORTH HIGH SCHOOL	COORDINATOR-GRADE LEVEL	08/06/2025
DALTON, REBECCA A	DISTRICT WIDE	NATIONAL BOARD CERTIFICATION	08/06/2025
DARK, ANN C	BLUE VALLEY WEST HIGH SCHOOL	ADDL TEACHING PLAN-YEAR	08/06/2025
DARK, ANN C	BLUE VALLEY WEST HIGH SCHOOL	DEPARTMENT CHAIR-CTE	08/06/2025
DAVIDSON, MARGARET SUE	BLUE VALLEY SOUTHWEST HS	ADDL TEACHING SUPV-YEAR	08/06/2025
DAVILA TORRES, SOFIA D	DISTRICT WIDE	LIMITED SUPPLY 3 OF 3	09/16/2025
DAVIS, DAVID L	HARMONY MIDDLE SCHOOL	ASST COACH-TRACK	03/01/2026
DE LEIRIS, JULIEN PIERRE HERVE	OVERLAND TRAIL MIDDLE SCHOOL	ASST SPONSOR-SCIENCE OLYMPIAD	09/11/2025
DEFFER, LAURA ANN	BLUE VALLEY NORTHWEST HS	12 EXTENDED DAYS-DEPT CHAIR	08/06/2025
DEFFER, LAURA ANN	BLUE VALLEY NORTHWEST HS	DEPARTMENT CHAIR-MATH	08/06/2025
DEFFER, NICHOLAS ANTHONY	BLUE VALLEY HIGH SCHOOL	ADDL TEACHING PLAN-YEAR	08/06/2025
DELGROSSO, ABIGAIL ROSE	BLUE VALLEY MIDDLE SCHOOL	SUPERVISOR-1/2 HR LUNCHROOM	08/06/2025
DICKERSON, STACEY E	PLEASANT RIDGE MIDDLE SCHOOL	SUPERVISOR-1/2 HR LUNCHROOM	08/06/2025
DICKERSON, TYLER JOHN	BLUE VALLEY WEST HIGH SCHOOL	ADDL TEACHING PLAN-1ST SEM	08/06/2025
DICKINSON, JAYMES EDWARD	BLUE VALLEY SOUTHWEST HS	SUPERVISOR-LUNCHROOM	08/06/2025
DILLON, JORDAN ZACHARY	BLUE VALLEY HIGH SCHOOL	ADDL TEACHING SUPV-YEAR	08/06/2025
DINSMORE, JACKSON RILEY	BLUE VALLEY NORTH HIGH SCHOOL	COORDINATOR-GRADE LEVEL	08/06/2025
DIXON, KRISTI L	DISTRICT WIDE	COORDINATOR-COUNSELING	08/06/2025
DIXON, KRISTI L	DISTRICT WIDE	DRUG & ALCOHOL COORDINATOR	09/01/2025
DOCKENDORF, SARAH ANN	BLUE VALLEY NORTH HIGH SCHOOL	SUPERVISOR-LUNCHROOM	08/06/2025
DOWNEY, BRITTANY LYNN	AUBRY BEND MIDDLE SCHOOL	ASST DIRECTOR-FALL MUSICAL	08/16/2025
DOWNEY, BRITTANY LYNN	DISTRICT WIDE	LIMITED SUPPLY 3 OF 3	09/16/2025
DREW, MOLLY MARGARET	DISTRICT WIDE	LIMITED SUPPLY 3 OF 3	09/16/2025
DREYER, MIKAYLA WEBER	DISTRICT WIDE	BCBA CERTIFICATION	08/06/2025
DUGAN, JENNIFER GILL	DISTRICT WIDE	NATIONAL BOARD CERTIFICATION	08/06/2025
DUGAN, JENNIFER GILL	OXFORD MIDDLE SCHOOL	SPONSOR-NEWSPAPER	08/06/2025
DUGAN, JENNIFER GILL	OXFORD MIDDLE SCHOOL	SPONSOR-STUDENT COUNCIL	08/06/2025
DUGAN, JENNIFER GILL	OXFORD MIDDLE SCHOOL	SUPERVISOR-1/2 HR LUNCHROOM	08/06/2025



Human Resources Report to the Board of Education

Addendum

October 13, 2025

Administration recommends approval of the following actions:

DUGAN, MOLLY MARIE	DISTRICT WIDE	LIMITED SUPPLY 2 OF 3	09/16/2025
DUGGAN, JENNIFER ANNE	DISTRICT WIDE	NATIONAL BOARD CERTIFICATION	08/06/2025
DUMMITT, ANNE MARIE	LAKESWOOD MIDDLE SCHOOL	SUPERVISOR-1/2 HR LUNCHROOM	08/06/2025
DUNN, ANNA LEIGH	BLUE VALLEY WEST HIGH SCHOOL	COORDINATOR-GRADE LEVEL	08/06/2025
DUNN, ANNA LEIGH	BLUE VALLEY WEST HIGH SCHOOL	DEPARTMENT CHAIR-FOREIGN LNG	08/06/2025
DURDYEVA, MAHRI	DISTRICT WIDE	LIMITED SUPPLY 3 OF 3	09/16/2025
ECKROAT, JENNIFER MICHELLE	DISTRICT WIDE	NATIONAL BOARD CERTIFICATION	08/06/2025
EHRET, BENJAMIN JAMES	BLUE VALLEY WEST HIGH SCHOOL	ADDL TEACHING PLAN-YEAR	08/06/2025
EHRET, BENJAMIN JAMES	DISTRICT WIDE	LIMITED SUPPLY 3 OF 3	09/16/2025
ELGIN, DEANNA PAIGE	BLUE VALLEY NORTHWEST HS	COORDINATOR-GRADE LEVEL	08/06/2025
ENGEL, CASEY KATHLEEN	BLUE VALLEY HIGH SCHOOL	DEPARTMENT CHAIR-COMM ARTS	08/06/2025
ERBACHER, STEVEN ELVIS	BLUE VALLEY HIGH SCHOOL	ASST COACH-BOYS BASKETBALL	11/16/2025
ERNST, LIZABETH LEON	BLUE VALLEY HIGH SCHOOL	ASST DIRECTOR-FALL MUSICAL	10/02/2025
ERPELDING, JUDY ELLEN	DISTRICT WIDE	LIMITED SUPPLY 3 OF 3	09/16/2025
ESPITIA, SANDY DIANA	BLUE VALLEY WEST HIGH SCHOOL	ADDL TEACHING PLAN-YEAR	08/06/2025
ESPITIA, SANDY DIANA	DISTRICT WIDE	NATIONAL BOARD CERTIFICATION	08/06/2025
ESSEX, STEPHEN	PRAIRIE STAR MIDDLE SCHOOL	ASST COACH-BOYS BASKETBALL	11/16/2025
ESSEX, STEPHEN	PRAIRIE STAR MIDDLE SCHOOL	SUPERVISOR-1/2 HR LUNCHROOM	08/06/2025
FELKE BOWDEN, CAREY ANNE	CEDAR HILLS ELEMENTARY	DIRECTOR-CHOIR	08/06/2025
FERGUSON, ASHLEY STEELE	DISTRICT WIDE	LIMITED SUPPLY 3 OF 3	09/16/2025
FERNANDEZ, VANESSA MARIA	OVERLAND TRAIL MIDDLE SCHOOL	SUPERVISOR-1/2 HR LUNCHROOM	08/06/2025
FINE, ERIN PATRICIA	BLUE VALLEY SOUTHWEST HS	COORDINATOR-BUILDING ADVISORY	08/06/2025
FISCHER, KATHERINE MIKAYLA	LAKESWOOD MIDDLE SCHOOL	ASST DIRECTOR-SPRING MUSICAL	11/16/2025
FISHER, TESSA LYNN	BLUE VALLEY NORTHWEST HS	COORDINATOR-GRADE LEVEL	08/06/2025
FLEMING, JULIA R	DISTRICT WIDE	LIMITED SUPPLY 3 OF 3	09/16/2025
FOLLOWELL, LISA MARIE	OXFORD MIDDLE SCHOOL	SUPERVISOR-1/2 HR LUNCHROOM	08/06/2025
FOOTE, JORDAN RICHARD	BLUE VALLEY SOUTHWEST HS	6 EXTENDED DAYS-DEPT CHAIR	08/06/2025
FOOTE, JORDAN RICHARD	BLUE VALLEY SOUTHWEST HS	DEPARTMENT CHAIR-PERFORM ARTS	08/06/2025
FORNELLI, RYLIE MICHELE	BLUE VALLEY SOUTHWEST HS	DEPARTMENT CHAIR-SPED	08/06/2025
FORNELLI, RYLIE MICHELE	DISTRICT WIDE	LIMITED SUPPLY 3 OF 3	09/16/2025
FRANEY, LYNN GABRIELLE	DISTRICT WIDE	NATIONAL BOARD CERTIFICATION	08/06/2025
FRANKLIN, HARRISON DAVID	LAKESWOOD MIDDLE SCHOOL	ASST DIRECTOR-FALL PLAY	08/16/2025
FRIEDEBACH, WILLIAM G	DISTRICT WIDE	LIMITED SUPPLY 3 OF 3	09/16/2025
FRITZ, ANN M	BLUE VALLEY NORTH HIGH SCHOOL	DEPARTMENT CHAIR-PE	08/06/2025
FROMME, KYMBERLY LYNNE	OXFORD MIDDLE SCHOOL	ASST DIRECTOR-FALL PLAY	08/16/2025
FROMME, KYMBERLY LYNNE	OXFORD MIDDLE SCHOOL	ASST DIRECTOR-SPRING MUSICAL	11/16/2025
FROMME, KYMBERLY LYNNE	OXFORD MIDDLE SCHOOL	LEADERSHIP TEAM MEMBER	08/06/2025
FROST, HOLLY JOELLE	DISTRICT WIDE	LIMITED SUPPLY 3 OF 3	09/16/2025
GALL, MOLLY MAHER	DISTRICT WIDE	LIMITED SUPPLY 2 OF 3	09/16/2025
GALLEGOS, JAMEY L	DISTRICT WIDE	LIMITED SUPPLY 2 OF 3	09/16/2025
GARCIA, KYLIE RENEE	BLUE VALLEY HIGH SCHOOL	DEPARTMENT CHAIR-FOREIGN LNG	08/06/2025
GARCIA, MARIA INES	HARMONY MIDDLE SCHOOL	ASST COACH-TRACK	03/01/2026
GASSMAN, OLIVIA M	DISTRICT WIDE	LIMITED SUPPLY 3 OF 3	09/16/2025
GAY, SUZANNE LORENE	DISTRICT WIDE	LEADERSHIP STIPEND-OT	08/06/2025



Human Resources Report to the Board of Education

Addendum

October 13, 2025

Administration recommends approval of the following actions:

GAY, SUZANNE LORENE	EDUCATIONAL SUPPORT CENTER	MENTOR-NEW TO BV OT	08/06/2025
GERFEN, CHRISTI LEA	DISTRICT WIDE	LIMITED SUPPLY 2 OF 3	09/16/2025
GERFEN, CRAIG W	DISTRICT WIDE	LIMITED SUPPLY 2 OF 3	09/16/2025
GESSLEY, JENNIFER ANN	DISTRICT WIDE	NATIONAL BOARD CERTIFICATION	08/06/2025
GEYER, AMANDA MAE	DISTRICT WIDE	LIMITED SUPPLY 3 OF 3	09/16/2025
GIULIANI, GABRIELLA N	DISTRICT WIDE	LIMITED SUPPLY 3 OF 3	09/16/2025
GO, MELISSIA MARIE	BLUE VALLEY SOUTHWEST HS	SUPERVISOR-LUNCHROOM	08/06/2025
GOLDEN, VALERIE VRANA	BLUE VALLEY NORTHWEST HS	12 EXTENDED DAYS-DEPT CHAIR	08/06/2025
GOLDEN, VALERIE VRANA	BLUE VALLEY NORTHWEST HS	DEPARTMENT CHAIR-COMM ARTS	08/06/2025
GOLDEN, VALERIE VRANA	DISTRICT WIDE	NATIONAL BOARD CERTIFICATION	08/06/2025
GOODEN, AUSTIN EDWARD	AUBRY BEND MIDDLE SCHOOL	SUPERVISOR-1/2 HR LUNCHROOM	08/06/2025
GOODWIN, STEPHANIE LYNN	DISTRICT WIDE	LIMITED SUPPLY 3 OF 3	09/16/2025
GORMLEY, ALEXIS NICOLE	DISTRICT WIDE	LEADERSHIP STIPEND-PSYCH	08/06/2025
GOUGER, JILL MARIE	OXFORD MIDDLE SCHOOL	CRD-STUDENT & COMM ENGAGEMENT	08/06/2025
GRAHAM, JANET LYNN	CENTER FOR ADV PROF STUDIES	ADDL TEACHING RESPONSIBILITIES	08/06/2025
GRAHAM, JANET LYNN	CENTER FOR ADV PROF STUDIES	CAPS BUSINESS PARTNERSHIP	08/06/2025
GRAHAM, JANET LYNN	CENTER FOR ADV PROF STUDIES	HEAD SPONSOR-DECA/FBLA/BPA	08/06/2025
GREEN, JENNIFER KATHERINE	BLUE VALLEY MIDDLE SCHOOL	LEADERSHIP TEAM MEMBER	08/06/2025
GREER, ANGELA JOY	DISTRICT WIDE	LIMITED SUPPLY 3 OF 3	09/16/2025
GRIMALDI, COURTNEY DANIELLE	BLUE VALLEY WEST HIGH SCHOOL	DEPARTMENT CHAIR-ADVISORY	08/06/2025
GRIMALDI, COURTNEY DANIELLE	BLUE VALLEY WEST HIGH SCHOOL	DEPARTMENT CHAIR-LIBRARY	08/06/2025
GRIMSLEY, HEATHER A	AUBRY BEND MIDDLE SCHOOL	LEADERSHIP TEAM MEMBER	08/06/2025
GRINDSTAFF, ADAM H	DISTRICT WIDE	FACILITATOR-CURRICULUM TRAININ	08/06/2025
GRINDSTAFF, ADAM H	LAKWOOD MIDDLE SCHOOL	LEADERSHIP TEAM MEMBER	08/06/2025
GRINDSTAFF, ADAM H	LAKWOOD MIDDLE SCHOOL	SUPERVISOR-1/2 HR LUNCHROOM	08/06/2025
GROSPITCH, THERESA LYNN	BLUE VALLEY WEST HIGH SCHOOL	ADDL TEACHING PLAN-YEAR	08/06/2025
GROSPITCH, THERESA LYNN	BLUE VALLEY WEST HIGH SCHOOL	DEPARTMENT CHAIR-MATH	08/06/2025
GROSPITCH, THERESA LYNN	DISTRICT WIDE	NATIONAL BOARD CERTIFICATION	08/06/2025
GROSPITCH, THERESA LYNN	DISTRICT WIDE	FACILITATOR-CURRICULUM TRAININ	08/06/2025
GRUSENMEYER, MOLLY ANNE	PLEASANT RIDGE MIDDLE SCHOOL	SPONSOR-STUDENT COUNCIL	08/06/2025
GRUSENMEYER, MOLLY ANNE	OXFORD MIDDLE SCHOOL	ASST DIRECTOR-FALL PLAY	08/16/2025
GUDENKAUF, AMY SUSAN	BLUE VALLEY NORTH HIGH SCHOOL	ADDL TEACHING SUPV-YEAR	08/06/2025
GUTHRIE, ERIN D	BLUE VALLEY NORTH HIGH SCHOOL	DEPARTMENT CHAIR-FACS	08/06/2025
GUTHRIE, ERIN D	BLUE VALLEY NORTHWEST HS	COORDINATOR-GRADE LEVEL	08/06/2025
GUTIERREZ, CONNY DANIELA	DISTRICT WIDE	LIMITED SUPPLY 2 OF 3	09/16/2025
GUTIERREZ, CONNY DANIELA	DISTRICT WIDE	NATIONAL BOARD CERTIFICATION	08/06/2025
HAGAN, CHRISTY S	DISTRICT WIDE	LIMITED SUPPLY 3 OF 3	09/16/2025
HAGAN, MICHAEL JOSEPH	BLUE VALLEY NORTHWEST HS	ADDL TEACHING PLAN-2ND SEM	01/05/2026
HAGGERTY, MOLLY ANN	DISTRICT WIDE	NATIONAL BOARD CERTIFICATION	08/06/2025
HAGSTROM, HEATHER MARIE	VIRTUAL ED	VIRTUAL EDUCATION-FALL	08/06/2025
HALEY, JOHN ISAAC	BLUE VALLEY WEST HIGH SCHOOL	ADDL TEACHING PLAN-YEAR	08/06/2025
HALL, HEATHER ELIZABETH	BLUE VALLEY WEST HIGH SCHOOL	DEPARTMENT CHAIR-SCIENCE	08/06/2025
HALL, HEATHER ELIZABETH	LEAWOOD MIDDLE SCHOOL	ASST SPONSOR-SCIENCE OLYMPIAD	09/22/2025
HALL, SANDRA BIDDLE	CENTER FOR ADV PROF STUDIES	ADDL TEACHING RESPONSIBILITIES	08/06/2025
HAMERA, AMY REBECCA			



Human Resources Report to the Board of Education

Addendum

October 13, 2025

Administration recommends approval of the following actions:

HAMERA, AMY REBECCA	CENTER FOR ADV PROF STUDIES	CAPS BUSINESS PARTNERSHIP	08/06/2025
HANTLA, GABRIELLA JOY	OVERLAND TRAIL MIDDLE SCHOOL	HEAD COACH-WRESTLING BOYS	11/16/2025
HANTLA, GABRIELLA JOY	OVERLAND TRAIL MIDDLE SCHOOL	HEAD COACH-WRESTLING GIRLS	11/16/2025
HARVEY, ANNE MARIE	DISTRICT WIDE	DIST CRD-STUDENT & COMM ENGMNT	08/06/2025
HASSELBRING, KELSEY LOUISE	BLUE VALLEY MIDDLE SCHOOL	HEAD COACH-GIRLS TRACK	03/01/2026
HASSELBRING, KELSEY LOUISE	BLUE VALLEY MIDDLE SCHOOL	SUPERVISOR-1/2 HR LUNCHROOM	08/06/2025
HASSELBRING, KELSEY LOUISE	VIRTUAL ED	VIRTUAL EDUCATION-FALL	08/06/2025
HEALY, REBECCA ANN	DISTRICT WIDE	LEADERSHIP STIPEND-SLP	08/06/2025
HEARNS, MARY DEIRDRE	DISTRICT WIDE	LIMITED SUPPLY 2 OF 3	09/16/2025
HEDLUND, TRENTON J	BLUE VALLEY NORTH HIGH SCHOOL	SUPERVISOR-GYMNASIUM	11/16/2025
HEERE, ALLISON KIRBY	OAK HILL ELEMENTARY	16 EXTENDED DAYS-IDC	08/06/2025
HEERE, ALLISON KIRBY	CEDAR HILLS ELEMENTARY	16 EXTENDED DAYS-IDC	08/06/2025
HEIDESCH, SARAH ELIZABETH	DISTRICT WIDE	LIMITED SUPPLY 2 OF 3	10/01/2025
HELLWIG, MATTIE B	DISTRICT WIDE	LIMITED SUPPLY 3 OF 3	09/16/2025
HENDERSON, KAREN MS	BLUE VALLEY NORTHWEST HS	ADDL TEACHING PLAN-YEAR	08/06/2025
HENDERSON, KAREN MS	DISTRICT WIDE	FACILITATOR-CURRICULUM TRAININ	08/06/2025
HENDERSON, KAREN MS	DISTRICT WIDE	NATIONAL BOARD CERTIFICATION	08/06/2025
HILLEN, KARI ANN	BLUE VALLEY NORTHWEST HS	8 EXTENDED DAYS-DEPT CHAIR	08/06/2025
HIRONS, ALISON ELIZABETH	DISTRICT WIDE	LIMITED SUPPLY 3 OF 3	09/16/2025
HOCHLER, JULIE ANN	DISTRICT WIDE	LIMITED SUPPLY 3 OF 3	09/16/2025
HOEVEN, MARIE ANN	BLUE VALLEY WEST HIGH SCHOOL	ADDL TEACHING PLAN-YEAR	08/06/2025
HOGAN, NICOLE K	DISTRICT WIDE	LIMITED SUPPLY 2 OF 3	09/16/2025
HOGLUND, KIMBERLY JO	DISTRICT WIDE	LIMITED SUPPLY 2 OF 3	09/16/2025
HOGLUND, KIMBERLY JO	DISTRICT WIDE	NATIONAL BOARD CERTIFICATION	08/06/2025
HOING, JENNA MARIE	BLUE VALLEY NORTHWEST HS	8 EXTENDED DAYS-DEPT CHAIR	08/06/2025
HOING, JENNA MARIE	BLUE VALLEY NORTHWEST HS	DEPARTMENT CHAIR-SPED	08/06/2025
HOIT, LYNDI LEE	DISTRICT WIDE	LIMITED SUPPLY 3 OF 3	09/16/2025
HOLEHAN, TRAVIS PATRICK	BLUE VALLEY WEST HIGH SCHOOL	ADDL TEACHING PLAN-YEAR	08/06/2025
HOLKER, HOLLY ANNE	DISTRICT WIDE	LIMITED SUPPLY 2 OF 3	09/16/2025
HOLLAND, TOM E	BLUE VALLEY NORTH HIGH SCHOOL	DEPARTMENT CHAIR-ART	08/06/2025
HOLLIS, BLAIR CAITLIN	HARMONY MIDDLE SCHOOL	ASST COACH-TRACK	03/01/2026
HOLLIS, BLAIR CAITLIN	HARMONY MIDDLE SCHOOL	SUPERVISOR-1/2 HR LUNCHROOM	08/06/2025
HOLSAPPLE, MEGAN KRISTINA	LAKESWOOD MIDDLE SCHOOL	SUPERVISOR-1/2 HR LUNCHROOM	08/06/2025
HOLTHAUS, AARON FRANCIS	CENTER FOR ADV PROF STUDIES	ADDL TEACHING RESPONSIBILITIES	08/06/2025
HOLTHAUS, AARON FRANCIS	CENTER FOR ADV PROF STUDIES	CAPS BUSINESS PARTNERSHIP	08/06/2025
HOLUB, HILLARY ANNE	DISTRICT WIDE	LIMITED SUPPLY 2 OF 3	09/16/2025
HONNOLD, RACHAEL A	OVERLAND TRAIL MIDDLE SCHOOL	ASST DIRECTOR-FALL MUSICAL	08/16/2025
HORA, CAMERON MICHAEL	DISTRICT WIDE	LIMITED SUPPLY 3 OF 3	09/16/2025
HORSTICK, JESSICA ELIZABETH	BLUE VALLEY WEST HIGH SCHOOL	ADDL TEACHING PLAN-YEAR	08/06/2025
HOUSTON, TIMOTHY MICHAEL	HARMONY MIDDLE SCHOOL	ASST DIRECTOR-SPRING MUSICAL	11/16/2025
HOWARD, DEREK LEE	BLUE VALLEY WEST HIGH SCHOOL	DEPARTMENT CHAIR-PE	08/06/2025
HOWARD, GARY LEON	BLUE VALLEY NORTHWEST HS	ADMIN CONSULTATNT SUPV STIP	08/06/2025
HOYLE, KAITLIN KAE	DISTRICT WIDE	LIMITED SUPPLY 1 OF 3	09/16/2025
HUDNALL, SYDNEY MARIE	DISTRICT WIDE	LIMITED SUPPLY 3 OF 3	09/16/2025



Human Resources Report to the Board of Education

Addendum

October 13, 2025

Administration recommends approval of the following actions:

HULL, COURTNEY ANN	DISTRICT WIDE	LIMITED SUPPLY 2 OF 3	09/16/2025
HUNT, ELYSE E	DISTRICT WIDE	LIMITED SUPPLY 3 OF 3	09/16/2025
HUO, QIUJU	BLUE VALLEY NORTH HIGH SCHOOL	ADDL TEACHING PLAN-YEAR	08/06/2025
HURLBUT, ERICA LAIRD	HARMONY MIDDLE SCHOOL	LEADERSHIP TEAM MEMBER	08/06/2025
HURST, KIMBERLY AUSTIN	BLUE VALLEY MIDDLE SCHOOL	LEADERSHIP TEAM MEMBER	08/06/2025
HUSS, MICHELLE NICOLE	DISTRICT WIDE	FACILITATOR-CURRICULUM TRAININ	08/06/2025
ISELL, TRISTAN PATRICK	OXFORD MIDDLE SCHOOL	SUPERVISOR-1/2 HR LUNCHROOM	08/06/2025
ISELL, TRISTAN PATRICK	VIRTUAL ED	VIRTUAL EDUCATION-FALL	08/06/2025
JACKSON, LISA INEZ	OVERLAND TRAIL MIDDLE SCHOOL	HEAD COACH-BOYS TRACK	03/01/2026
JACOBS, JESSICA RENEE	DISTRICT WIDE	LIMITED SUPPLY 3 OF 3	09/16/2025
JAMES, BRITTANIE RENEE	DISTRICT WIDE	LIMITED SUPPLY 3 OF 3	09/16/2025
JENSEN, JAMES HENRY	BLUE VALLEY MIDDLE SCHOOL	ASST COACH-FOOTBALL	08/16/2025
JIN, SOOJIN CLARA	SUNSET RIDGE ELEMENTARY	DIRECTOR-CHOIR	09/19/2025
JOHNSTON, MICHAEL A	BLUE VALLEY HIGH SCHOOL	DEPARTMENT CHAIR-ART	08/06/2025
JONES, CROSBY ANN	OVERLAND TRAIL MIDDLE SCHOOL	SUPERVISOR-1/2 HR LUNCHROOM	08/06/2025
JURKOVAC, JESSICA E	AUBRY BEND MIDDLE SCHOOL	ASST COACH-CROSS COUNTRY	08/16/2025
KANAN, WILLIAM HENRY	LEAWOOD MIDDLE SCHOOL	SUPERVISOR-1/2 HR LUNCHROOM	08/06/2025
KANAREK, ELI S	BLUE VALLEY HIGH SCHOOL	DEPARTMENT CHAIR-SPED	08/06/2025
KARR, BROOKE D	DISTRICT WIDE	LIMITED SUPPLY 3 OF 3	09/16/2025
KAUR, PAWANDEEP	DISTRICT WIDE	LIMITED SUPPLY 1 OF 3	09/16/2025
KELLER, MEGAN LEIGH	DISTRICT WIDE	LIMITED SUPPLY 2 OF 3	09/16/2025
KELLER, STEPHANIE SUSAN	DISTRICT WIDE	DRUG & ALCOHOL COORDINATOR	09/01/2025
KENNEY, KATIE MARCELA	DISTRICT WIDE	LIMITED SUPPLY 2 OF 3	09/16/2025
KESSLER, ERIC M	CENTER FOR ADV PROF STUDIES	ADDL TEACHING RESPONSIBILITIES	08/06/2025
KESSLER, ERIC M	CENTER FOR ADV PROF STUDIES	CAPS BUSINESS PARTNERSHIP	08/06/2025
KESSLER, ERIC M	CENTER FOR ADV PROF STUDIES	CAPS STRAND LEADER	08/06/2025
KESSLER, ERIC M	DISTRICT WIDE	NATIONAL BOARD CERTIFICATION	08/06/2025
KINKELAAR, KERRY MAE	DISTRICT WIDE	NATIONAL BOARD CERTIFICATION	08/06/2025
KIRK, DELANEY LOGAN	LIBERTY VIEW ELEMENTARY	DIRECTOR-CHOIR	08/06/2025
KISSANE, KEVIN PATRICK	BLUE VALLEY WEST HIGH SCHOOL	ASST COACH-WRESTLING BOYS	11/16/2025
KNEIB, KADI L	DISTRICT WIDE	LIMITED SUPPLY 3 OF 3	09/16/2025
KOCH, BARRET LUCAS	AUBRY BEND MIDDLE SCHOOL	ADDL TEACHING PLAN-1ST SEM	08/06/2025
KOCH, BARRET LUCAS	LEAWOOD MIDDLE SCHOOL	ADDL TEACHING RESPONSIBILITIES	08/06/2025
KOCH, BARRET LUCAS	AUBRY BEND MIDDLE SCHOOL	LEADERSHIP TEAM MEMBER	08/06/2025
KOZLOWSKI, ERIN NICOLE	DISTRICT WIDE	LIMITED SUPPLY 3 OF 3	09/16/2025
KREHBIEL, LINDSAY RENEE	BLUE VALLEY WEST HIGH SCHOOL	ADDL TEACHING PLAN-2ND SEM	01/05/2026
KREHBIEL, LINDSAY RENEE	VIRTUAL ED	VIRTUAL EDUCATION-FALL	08/06/2025
KREWSON, SICILEY P	BLUE VALLEY SOUTHWEST HS	ADDL TEACHING PLAN-2ND SEM	01/05/2026
KREWSON, SICILEY P	BLUE VALLEY SOUTHWEST HS	DEPARTMENT CHAIR-CTE	08/06/2025
KREWSON, SICILEY P	DISTRICT WIDE	FACILITATOR-CURRICULUM TRAININ	08/06/2025
KROEKER, BRIAN SCOTT	BLUE VALLEY WEST HIGH SCHOOL	DEPARTMENT CHAIR-ART	08/06/2025
KRULIK, JACLYN LEE	BLUE VALLEY NORTH HIGH SCHOOL	ASST DIRECTOR-WINTER MUSICAL	11/16/2025
KRULIK, JACLYN LEE	BLUE VALLEY NORTH HIGH SCHOOL	DIRECTOR-WINTER MUSICAL	11/16/2025
KUHLMAN, JAIME MICHELLE	DISTRICT WIDE	LIMITED SUPPLY 2 OF 3	09/16/2025



Human Resources Report to the Board of Education

Addendum

October 13, 2025

Administration recommends approval of the following actions:

LABELLE, EMILY C	PRAIRIE STAR MIDDLE SCHOOL	SUPERVISOR-1/2 HR LUNCHROOM	08/06/2025
LAHASKY, ALEX W	BLUE VALLEY WEST HIGH SCHOOL	ADDL TEACHING PLAN-YEAR	08/06/2025
LAHASKY, ALEX W	BLUE VALLEY WEST HIGH SCHOOL	DEPARTMENT CHAIR-SOC SCIENCE	08/06/2025
LAHASKY, JENNIFER LYNN	LEAWOOD MIDDLE SCHOOL	SUPERVISOR-1/2 HR LUNCHROOM	08/06/2025
LANG, PAIGE M	DISTRICT WIDE	LIMITED SUPPLY 2 OF 3	09/16/2025
LANGE, CORBY NELSON	BLUE VALLEY NORTHWEST HS	12 EXTENDED DAYS-DEPT CHAIR	08/06/2025
LANGE, CORBY NELSON	BLUE VALLEY NORTHWEST HS	DEPARTMENT CHAIR-SOC SCIENCE	08/06/2025
LANGE, CORBY NELSON	VIRTUAL ED	VIRTUAL EDUCATION-FALL	08/06/2025
LAUNIUS, RACHEL CHRISTINE	DISTRICT WIDE	LIMITED SUPPLY 1 OF 3	11/17/2025
LAVALLEY, CHRISTINE ANN	BLUE VALLEY NORTHWEST HS	8 EXTENDED DAYS-DEPT CHAIR	08/06/2025
LAVALLEY, CHRISTINE ANN	BLUE VALLEY NORTHWEST HS	DEPARTMENT CHAIR-ART	08/06/2025
LEBAR, JOSEPH S	DISTRICT WIDE	LIMITED SUPPLY 2 OF 3	09/16/2025
LEFEVRE, MICHELLE LAUREN	BLUE VALLEY NORTHWEST HS	COORDINATOR-GRADE LEVEL	08/06/2025
LEFEVRE, MICHELLE LAUREN	DISTRICT WIDE	LIMITED SUPPLY 3 OF 3	09/16/2025
LEGROTTE, JENNIFER CARRIE	BLUE VALLEY WEST HIGH SCHOOL	ADDL TEACHING SUPV-YEAR	08/06/2025
LEIGHTON, KYLA J	BLUE VALLEY ACADEMY	SUPERVISOR-LUNCHROOM	08/06/2025
LENERTZ, OLIVIA KATHRYN	BLUE VALLEY NORTH HIGH SCHOOL	12 EXTENDED DAYS-DEPT CHAIR	08/06/2025
LENERTZ, OLIVIA KATHRYN	BLUE VALLEY NORTH HIGH SCHOOL	DEPARTMENT CHAIR-MATH	08/06/2025
LERDAL, SARAH DOROTHY	BLUE VALLEY WEST HIGH SCHOOL	COORDINATOR-GRADE LEVEL	08/06/2025
LEVIN, AMANDA ROSE	BLUE VALLEY NORTH HIGH SCHOOL	DEPARTMENT CHAIR-COUNSELOR	08/06/2025
LEVY, BENJAMIN JOSEPH	BLUE VALLEY NORTH HIGH SCHOOL	DEPARTMENT CHAIR-BUSINESS	08/06/2025
LEVY, JAMES M	OVERLAND TRAIL MIDDLE SCHOOL	SUPERVISOR-1/2 HR LUNCHROOM	08/06/2025
LEW, MOI MOOI	VALLEY PARK ELEMENTARY	ADDL TEACHING CI-YEAR	08/06/2025
LI, PAULA L	DISTRICT WIDE	LIMITED SUPPLY 3 OF 3	09/16/2025
LIND, LISA J	DISTRICT WIDE	LIMITED SUPPLY 3 OF 3	09/16/2025
LINTZ, PATRICIA JEAN	DISTRICT WIDE	LIMITED SUPPLY 2 OF 3	09/16/2025
LIU, ELAINE G	WOLF SPRINGS ELEMENTARY	ADDL TEACHING CI-YEAR	08/06/2025
LISTER, BRIDGET BAKER	HARMONY MIDDLE SCHOOL	ASST COACH-TRACK	03/01/2026
LISTER, BRIDGET BAKER	HARMONY MIDDLE SCHOOL	SUPERVISOR-1/2 HR LUNCHROOM	08/06/2025
LONG, JERALD ANDREW	PLEASANT RIDGE MIDDLE SCHOOL	SUPERVISOR-1/2 HR LUNCHROOM	08/06/2025
LOVGREN-URIBE, SAMANTHA D	EDUCATIONAL SUPPORT CENTER	CLIN FELLOW YR SUPV STIP-SLP	08/06/2025
LOWE, STACI LEA	BLUE VALLEY WEST HIGH SCHOOL	ADDL TEACHING PLAN-YEAR	08/06/2025
LUAL, BUOMKUOTH P	OVERLAND TRAIL MIDDLE SCHOOL	SUPERVISOR-1/2 HR LUNCHROOM	08/06/2025
LUEDERS, MCKENZIE K	CENTER FOR ADV PROF STUDIES	ADDL TEACHING RESPONSIBILITIES	08/06/2025
LUEDERS, MCKENZIE K	CENTER FOR ADV PROF STUDIES	CAPS BUSINESS PARTNERSHIP	08/06/2025
LUEDERS, MCKENZIE K	DISTRICT WIDE	FACILITATOR-CURRICULUM TRAININ	08/06/2025
LUNDINE, ADAM HARLAN	EDUCATIONAL SUPPORT CENTER	DIRECTOR-BAND DL	08/06/2025
LUNDINE, ADAM HARLAN	EDUCATIONAL SUPPORT CENTER	DIRECTOR-ORCHESTRA	08/06/2025
LUNDINE, ADAM HARLAN	EDUCATIONAL SUPPORT CENTER	DIRECTOR-VOCAL MUSIC	08/06/2025
LUNSFORD, CARA GLENN	BLUE VALLEY WEST HIGH SCHOOL	COORDINATOR-BUILDING ADVISORY	08/06/2025
LYNCH, COURTNEY MARY ELIZABETH	OXFORD MIDDLE SCHOOL	ASST DIRECTOR-FALL PLAY	08/16/2025
LYNN, JENNIFER ELIZABETH	DISTRICT WIDE	LIMITED SUPPLY 3 OF 3	09/16/2025
LYON, ROBIN L	EDUCATIONAL SUPPORT CENTER	CLIN FELLOW YR SUPV STIP-SLP	08/06/2025
LYON, ROBIN L	DISTRICT WIDE	LEADERSHIP STIPEND-SLP	08/06/2025



Human Resources Report to the Board of Education

Addendum

October 13, 2025

Administration recommends approval of the following actions:

MAASEN, ANGELA JEAN	VIRTUAL ED	VIRTUAL EDUCATION-FALL	08/06/2025
MACDONNELL, NICHOLAS	BLUE VALLEY WEST HIGH SCHOOL	ADDL TEACHING SUPV-YEAR	08/06/2025
MADDEN, LILLIAN MARIE	LEAWOOD MIDDLE SCHOOL	SUPERVISOR-1/2 HR LUNCHROOM	08/06/2025
MADDOX, SARA FRANCES	DISTRICT WIDE	LIMITED SUPPLY 3 OF 3	09/16/2025
MADISON, SHANNON LEA	PLEASANT RIDGE MIDDLE SCHOOL	SUPERVISOR-1/2 HR LUNCHROOM	08/06/2025
MADSEN, TRICIA LOUISE	DISTRICT WIDE	DRUG & ALCOHOL COORDINATOR	09/01/2025
MAHONEY, RYAN MICHAEL	BLUE VALLEY NORTHWEST HS	ASST COACH-BOYS BASKETBALL	11/16/2025
MAINS, ANNE ELIZABETH	DISTRICT WIDE	LIMITED SUPPLY 2 OF 3	09/16/2025
MANN, KALE HAMPTON	BLUE VALLEY HIGH SCHOOL	ADDL TEACHING PLAN-YEAR	08/06/2025
MANNING, ROBERT ALAN	HARMONY MIDDLE SCHOOL	ASST DIRECTOR-SPRING MUSICAL	11/16/2025
MANTIA, CHLOE A	DISTRICT WIDE	LIMITED SUPPLY 3 OF 3	09/16/2025
MARSHALL, ZAKIAH	DISTRICT WIDE	LIMITED SUPPLY 2 OF 3	09/16/2025
MARTENS, LAUREN	AUBRY BEND MIDDLE SCHOOL	ADDL TEACHING RESPONSIBILITIES	08/06/2025
MARTINEZ, BRADLEY MARTIN	BLUE VALLEY SOUTHWEST HS	ASST DIRECTOR-MARCHING BAND	08/16/2025
MASON, ALLISON MICHELLE	PLEASANT RIDGE MIDDLE SCHOOL	SUPERVISOR-1/2 HR LUNCHROOM	08/06/2025
MASON, LAURA ELIZABETH	BLUE VALLEY SOUTHWEST HS	COORDINATOR-GRADE LEVEL	08/06/2025
MAY, DANIELLE K	BLUE VALLEY WEST HIGH SCHOOL	ADDL TEACHING PLAN-YEAR	08/06/2025
MAY, DANIELLE K	DISTRICT WIDE	FACILITATOR-CURRICULUM TRAININ	08/06/2025
MCCARTY, MAXWELL PORTER	BLUE VALLEY NORTH HIGH SCHOOL	ASST COACH-DEBATE	08/16/2025
MCCARTY, PATRICK M	BLUE VALLEY NORTH HIGH SCHOOL	DIRECTOR-PEP BAND	11/16/2025
MCKEE, IAIN JOSEPH	OXFORD MIDDLE SCHOOL	SUPERVISOR-1/2 HR LUNCHROOM	08/06/2025
MCKEE, SARAH MARGARET	BLUE VALLEY SOUTHWEST HS	DEPARTMENT CHAIR-ART	08/06/2025
MCLAUGHLIN, TANNER D	DISTRICT WIDE	BCBA CERTIFICATION	08/06/2025
MEEK, STEPHANIE A	PLEASANT RIDGE MIDDLE SCHOOL	SUPERVISOR-1/2 HR LUNCHROOM	08/06/2025
MEISINGER, PEYTON JEAN	DISTRICT WIDE	BCBA CERTIFICATION	08/06/2025
MELTON, ANGELA LYN	HEARTLAND ELEMENTARY	ADDL TEACHING RESPONSIBILITIES	08/06/2025
MILLER, CARRIE LYNN	PLEASANT RIDGE MIDDLE SCHOOL	SUPERVISOR-1/2 HR LUNCHROOM	08/06/2025
MILLS, HEATHER L	PLEASANT RIDGE MIDDLE SCHOOL	SPONSOR-DIVERSITY CLUB	08/06/2025
MITCHELSON, KAYLEE JANE	HARMONY MIDDLE SCHOOL	ASST DIRECTOR-FALL PLAY	08/16/2025
MITCHELSON, KAYLEE JANE	HARMONY MIDDLE SCHOOL	ASST DIRECTOR-SPRING MUSICAL	11/16/2025
MODELSKI, KIMBERLY ANN	BLUE VALLEY WEST HIGH SCHOOL	DEPARTMENT CHAIR-PERFORM ARTS	08/06/2025
MOHN, JEREMY J	DISTRICT WIDE	NATIONAL BOARD CERTIFICATION	08/06/2025
MOLDE, MELISSA C	PRAIRIE STAR MIDDLE SCHOOL	16 EXTENDED DAYS-IDC	08/06/2025
MOLDE, MELISSA C	LEAWOOD MIDDLE SCHOOL	16 EXTENDED DAYS-IDC	08/06/2025
MOLDE, MELISSA C	PRAIRIE STAR MIDDLE SCHOOL	LEADERSHIP TEAM MEMBER	08/06/2025
MOLDE, MELISSA C	LEAWOOD MIDDLE SCHOOL	LEADERSHIP TEAM MEMBER	08/06/2025
MONSON, ANDREW JAMES	PLEASANT RIDGE MIDDLE SCHOOL	ADDL TEACHING RESPONSIBILITIES	08/06/2025
MONTGOMERY, MORGAN LYNN	DISTRICT WIDE	BCBA CERTIFICATION	08/06/2025
MOORE, CANDY DIANE	DISTRICT WIDE	DRUG & ALCOHOL COORDINATOR	09/01/2025
MORGAN, ERIN ASHLEIGH	BLUE VALLEY NORTH HIGH SCHOOL	ADDL TEACHING SUPV-YEAR	08/06/2025
MOSS, ELIJAH COLEMAN	AUBRY BEND MIDDLE SCHOOL	SUPERVISOR-1/2 HR LUNCHROOM	08/06/2025
MOWRY, BRIAN JAMES	BLUE VALLEY HIGH SCHOOL	DEPARTMENT CHAIR-SOC SCIENCE	08/06/2025
MUELLER, LOGAN C	DISTRICT WIDE	LIMITED SUPPLY 3 OF 3	09/16/2025
MUNSON, REBECCA STITH	DISTRICT WIDE	NATIONAL BOARD CERTIFICATION	08/06/2025



Human Resources Report to the Board of Education

Addendum

October 13, 2025

Administration recommends approval of the following actions:

MURKIN, HALEY N	DISTRICT WIDE	LIMITED SUPPLY 3 OF 3	09/16/2025
MURRAIN, LAUREN ROSE	DISTRICT WIDE	LIMITED SUPPLY 2 OF 3	09/16/2025
NATARAJAN, RAMA	HARMONY MIDDLE SCHOOL	ASST SPONSOR-SCIENCE OLYMPIAD	09/11/2025
NATHAN, ERIN LEA	BLUE VALLEY NORTH HIGH SCHOOL	COORDINATOR-GRADE LEVEL	08/06/2025
NAVARRO, NICOLAS ALEXANDER	BLUE VALLEY NORTH HIGH SCHOOL	ASST COACH-BOYS SOCCER	08/16/2025
NEWELL, LUCAS A	OVERLAND TRAIL MIDDLE SCHOOL	SUPERVISOR-1/2 HR LUNCHROOM	08/06/2025
NEWELL, LUCAS A	VIRTUAL ED	VIRTUAL EDUCATION-FALL	08/06/2025
NEWELL, ROSS WHITNEY	HARMONY MIDDLE SCHOOL	ASST COACH-BOYS BASKETBALL	11/16/2025
NEWELL, ROSS WHITNEY	HARMONY MIDDLE SCHOOL	ASST COACH-GIRLS BASKETBALL	11/16/2025
NEWELL, ROSS WHITNEY	HARMONY MIDDLE SCHOOL	ASST COACH-TRACK	03/01/2026
NEWELL, ROSS WHITNEY	HARMONY MIDDLE SCHOOL	SUPERVISOR-1/2 HR LUNCHROOM	08/06/2025
NEWTON, CHELSI ANN	DISTRICT WIDE	LIMITED SUPPLY 3 OF 3	09/16/2025
NIE, JUNYI	BLUE VALLEY HIGH SCHOOL	ASST DIRECTOR-FALL MUSICAL	08/16/2025
NOCITA, LISA THOMAS	DISTRICT WIDE	NATIONAL BOARD CERTIFICATION	08/06/2025
NOCITA, LISA THOMAS	PRAIRIE STAR MIDDLE SCHOOL	SUPERVISOR-1/2 HR LUNCHROOM	08/06/2025
NORVAL, ALEXANDRIA NICOLE	DISTRICT WIDE	LIMITED SUPPLY 2 OF 3	09/16/2025
O'BRYAN, DIANNE LYNN	BLUE VALLEY HIGH SCHOOL	ADDL TEACHING RESPONSIBILITIES	08/06/2025
O'BRYAN, DIANNE LYNN	BLUE VALLEY HIGH SCHOOL	DEPARTMENT CHAIR-COORD TCHR	08/06/2025
O'CONNELL, LAURA GRACE	BLUE VALLEY NORTH HIGH SCHOOL	COORDINATOR-GRADE LEVEL	08/06/2025
O'GORMAN, MICHAEL M	LEAWOOD MIDDLE SCHOOL	SUPERVISOR-1/2 HR LUNCHROOM	08/06/2025
O'KEEFE, NICHOLAS RYAN	BLUE VALLEY SOUTHWEST HS	ADDL TEACHING PLAN-YEAR	08/06/2025
O'KEEFE, NICHOLAS RYAN	DISTRICT WIDE	LIMITED SUPPLY 2 OF 3	09/16/2025
O'LEARY, KATELYN HANNAH	DISTRICT WIDE	BCBA CERTIFICATION	08/06/2025
OCON JR, JUAN	BLUE VALLEY NORTH HIGH SCHOOL	ADDL TEACHING PLAN-YEAR	08/06/2025
ODDO, KATHRYN ELIZABETH	HARMONY ELEMENTARY	AD INTERN SUPERVISION DUTIES	08/06/2025
ODLE, CRAIG TAYLOR	BLUE VALLEY NORTHWEST HS	3 EXTENDED DAYS-DEPT CHAIR	08/06/2025
ODLE, CRAIG TAYLOR	BLUE VALLEY NORTHWEST HS	DEPARTMENT CHAIR-LIBRARY	08/06/2025
OGLE, MADELINE ELLEN	BLUE VALLEY WEST HIGH SCHOOL	ASST COACH-TRACK	03/01/2026
OLDSON, MCKENNA LEE	HARMONY MIDDLE SCHOOL	SUPERVISOR-1/2 HR LUNCHROOM	08/06/2025
OLLIG, CHRIS B	BLUE VALLEY NORTH HIGH SCHOOL	DEPARTMENT CHAIR-SCIENCE	08/06/2025
OLNEY, BRANDON JAMES	DISTRICT WIDE	LIMITED SUPPLY 2 OF 3	09/16/2025
ORRICK, ANTHONY JOHN	BLUE VALLEY SOUTHWEST HS	4 EXTENDED DAYS-DEPT CHAIR	08/06/2025
ORRICK, ANTHONY JOHN	BLUE VALLEY SOUTHWEST HS	ADDL TEACHING SUPV-2ND SEM	01/05/2026
ORRICK, ANTHONY JOHN	BLUE VALLEY SOUTHWEST HS	DEPARTMENT CHAIR-PE	08/06/2025
ORTIZ, DENISE A	DISTRICT WIDE	LIMITED SUPPLY 3 OF 3	09/16/2025
OSBORNE, KATELYN A	DISTRICT WIDE	LIMITED SUPPLY 2 OF 3	09/16/2025
OSTERTAG, HANNAH SUE	DISTRICT WIDE	LIMITED SUPPLY 3 OF 3	09/16/2025
PALERMO, CHERIN LYNN	DISTRICT WIDE	NATIONAL BOARD CERTIFICATION	08/06/2025
PALMGREN JR, ROBERT MICHAEL	BLUE VALLEY SOUTHWEST HS	DEPARTMENT CHAIR-FOREIGN LNG	08/06/2025
PARKER, HALEY NICOLE	DISTRICT WIDE	BCBA CERTIFICATION	08/06/2025
PARKER, KATHRYN ANN	DISTRICT WIDE	LIMITED SUPPLY 2 OF 3	09/16/2025
PARKS, KATIE ROSE BARTOLAC	DISTRICT WIDE	LIMITED SUPPLY 1 OF 3	09/16/2025
PATINO-JIMENEZ, JUAN MANUEL	DISTRICT WIDE	NATIONAL BOARD CERTIFICATION	08/06/2025
PAYNE, HEATHER LYNN	WOLF SPRINGS ELEMENTARY	AD INTERN SUPERVISION DUTIES	08/06/2025



Human Resources Report to the Board of Education

Addendum

October 13, 2025

Administration recommends approval of the following actions:

PEARSON, ERIN K	BLUE VALLEY NORTHWEST HS	ADDL TEACHING PLAN-YEAR	08/06/2025
PEARSON, ERIN K	DISTRICT WIDE	NATIONAL BOARD CERTIFICATION	08/06/2025
PEARSON, KATHRYN IDA ANN	BLUE VALLEY NORTH HIGH SCHOOL	AD INTERN SUPERVISION DUTIES	08/06/2025
PERES, KATHY L	BLUE VALLEY HIGH SCHOOL	DEPARTMENT CHAIR-BUSINESS	08/06/2025
PERES, KATHY L	DISTRICT WIDE	FACILITATOR-CURRICULUM TRAININ	08/06/2025
PETERSEN, TODD MITCHELL	BLUE VALLEY NORTHWEST HS	12 EXTENDED DAYS-DEPT CHAIR	08/06/2025
PETERSEN, TODD MITCHELL	BLUE VALLEY NORTHWEST HS	DEPARTMENT CHAIR-COMM ARTS	08/06/2025
PHILLIPS, TATUM NICOLE	BLUE VALLEY MIDDLE SCHOOL	SPONSOR-DRILL/DANCE TEAM	08/06/2025
PHROMMANY, MACKENZIE ADAM	DISTRICT WIDE	LIMITED SUPPLY 2 OF 3	09/16/2025
PICKERT, AZADEH TAGHIZADEH	BLUE VALLEY HIGH SCHOOL	DEPARTMENT CHAIR-COORD TCHR	08/06/2025
PICKERT, AZADEH TAGHIZADEH	BLUE VALLEY HIGH SCHOOL	DEPARTMENT CHAIR-SCIENCE	08/06/2025
PINKER, JONATHAN ELTON	DISTRICT WIDE	LIMITED SUPPLY 2 OF 3	09/16/2025
PINKER, JONATHAN ELTON	AUBRY BEND MIDDLE SCHOOL	SUPERVISOR-1/2 HR LUNCHROOM	08/06/2025
PITTMAN, JOSEPH KEIL	VIRTUAL ED	VIRTUAL EDUCATION-FALL	08/06/2025
PORTER, ANNA NICOLE	BLUE VALLEY NORTH HIGH SCHOOL	8 EXTENDED DAYS-DEPT CHAIR	08/06/2025
PORTER, ANNA NICOLE	BLUE VALLEY NORTH HIGH SCHOOL	DEPARTMENT CHAIR-SPED	08/06/2025
PRAKASH, RAJASREE	BLUE VALLEY NORTH HIGH SCHOOL	ADDL TEACHING PLAN-YEAR	08/06/2025
PRATER, LINDSAY CARTHLEENA	BLUE RIVER ELEMENTARY	DIRECTOR-CHOIR	08/06/2025
PREDMORE-SOPER, PATRICIA M	HARMONY MIDDLE SCHOOL	SUPERVISOR-1/2 HR LUNCHROOM	08/06/2025
QUINN, ROXANNE HAZEL	OVERLAND TRAIL MIDDLE SCHOOL	SUPERVISOR-1/2 HR LUNCHROOM	08/06/2025
RAMIREZ, JENNA RENEE	HILLTOP LEARNING CENTER	ADDL TEACHING RESPONSIBILITIES	08/06/2025
RAMSEY, LORI ANN	WOLF SPRINGS ELEMENTARY	ADDL TEACHING CI-YEAR	08/06/2025
RASTOGI, SARAH ANN	LEAWOOD MIDDLE SCHOOL	HEAD SPONSOR-SCIENCE OLYMPIAD	09/19/2025
RATHBONE, BRODERIC R	LEAWOOD MIDDLE SCHOOL	SUPERVISOR-1/2 HR LUNCHROOM	08/06/2025
RAY, KRISTIN MICHELLE	DISTRICT WIDE	NATIONAL BOARD CERTIFICATION	08/06/2025
REDLIN, MAKAELE ANN	AUBRY BEND MIDDLE SCHOOL	SUPERVISOR-1/2 HR LUNCHROOM	08/06/2025
REEVES, ANDREW LAMAR	DISTRICT WIDE	FACILITATOR-CURRICULUM TRAININ	08/06/2025
REGIER, ERIC C	DISTRICT WIDE	LIMITED SUPPLY 3 OF 3	09/16/2025
REICHART, JOHN KEVIN	BLUE VALLEY NORTHWEST HS	3 EXTENDED DAYS-DEPT CHAIR	08/06/2025
REICHART, JOHN KEVIN	BLUE VALLEY NORTHWEST HS	DEPARTMENT CHAIR-PE	08/06/2025
REICHART, JOHN KEVIN	BLUE VALLEY NORTHWEST HS	SUPERVISOR-LUNCHROOM	08/06/2025
RESTIVO, LAURA M	BLUE VALLEY WEST HIGH SCHOOL	ADDL TEACHING PLAN-YEAR	08/06/2025
RESTIVO, LAURA M	BLUE VALLEY WEST HIGH SCHOOL	DEPARTMENT CHAIR-COMM ARTS	08/06/2025
REXROAT, ANDREW WILLIAM	DISTRICT WIDE	LIMITED SUPPLY 2 OF 3	09/16/2025
REYNOLDS, TINA DENAY	PRAIRIE STAR MIDDLE SCHOOL	SUPERVISOR-1/2 HR LUNCHROOM	08/06/2025
RICHARDS, CHRISTINE ROBERTA	PRAIRIE STAR MIDDLE SCHOOL	SUPERVISOR-1/2 HR LUNCHROOM	08/06/2025
RICKE, ELIZABETH ANNE	BLUE VALLEY NORTHWEST HS	4 EXTENDED DAYS-DEPT CHAIR	08/06/2025
RICKE, ELIZABETH ANNE	BLUE VALLEY NORTHWEST HS	DEPARTMENT CHAIR-COUNSELOR	08/06/2025
RIFFER, JILL C	CENTER FOR ADV PROF STUDIES	ADDL TEACHING RESPONSIBILITIES	08/06/2025
RIFFER, JILL C	CENTER FOR ADV PROF STUDIES	CAPS BUSINESS PARTNERSHIP	08/06/2025
RIFFER, JILL C	CENTER FOR ADV PROF STUDIES	CAPS STRAND LEADER	08/06/2025
RILEY, MILES ALEXANDER	CENTER FOR ADV PROF STUDIES	8 EXTENDED DAYS-STRAND LEADER	08/06/2025
RILEY, MILES ALEXANDER	CENTER FOR ADV PROF STUDIES	ADDL TEACHING RESPONSIBILITIES	08/06/2025
RILEY, MILES ALEXANDER	CENTER FOR ADV PROF STUDIES	CAPS BUSINESS PARTNERSHIP	08/06/2025



Human Resources Report to the Board of Education

Addendum

October 13, 2025

Administration recommends approval of the following actions:

RILEY, MILES ALEXANDER	CENTER FOR ADV PROF STUDIES	CAPS STRAND LEADER	08/06/2025
RILEY, MILES ALEXANDER	DISTRICT WIDE	FACILITATOR-CURRICULUM TRAININ	08/06/2025
RINDOM, HALLEY ANN	DISTRICT WIDE	LIMITED SUPPLY 3 OF 3	09/16/2025
RINEARSON, SHAUNA CHRISTINE	BLUE VALLEY SOUTHWEST HS	DEPARTMENT CHAIR-COMM ARTS	08/06/2025
RINEARSON, SHAUNA CHRISTINE	DISTRICT WIDE	NATIONAL BOARD CERTIFICATION	08/06/2025
RING, TINA LYNN	DISTRICT WIDE	LIMITED SUPPLY 3 OF 3	09/16/2025
RITZEL, MICHAEL E	DISTRICT WIDE	LIMITED SUPPLY 3 OF 3	09/16/2025
ROBERTS, MEGAN BLOOM	DISTRICT WIDE	NATIONAL BOARD CERTIFICATION	08/01/2025
ROBINSON, ERIN JO	BLUE VALLEY ACADEMY	SUPERVISOR-LUNCHROOM	08/06/2025
ROCHE, LEAH M	CENTER FOR ADV PROF STUDIES	ADDL TEACHING RESPONSIBILITIES	08/06/2025
ROCHE, LEAH M	CENTER FOR ADV PROF STUDIES	CAPS BUSINESS PARTNERSHIP	08/06/2025
RONDEAU, LESLIE MORGAN	DISTRICT WIDE	LIMITED SUPPLY 2 OF 2	09/16/2025
ROSE, JESSICA LAUREN	DISTRICT WIDE	LIMITED SUPPLY 3 OF 3	09/16/2025
ROSENBERG, SUSAN S	DISTRICT WIDE	NATIONAL BOARD CERTIFICATION	08/06/2025
RUTHERFORD, PAMELA ROSE	PLEASANT RIDGE MIDDLE SCHOOL	SUPERVISOR-1/2 HR LUNCHROOM	08/06/2025
RUTHERFORD, PAMELA ROSE	VIRTUAL ED	VIRTUAL EDUCATION-FALL	08/06/2025
SAFFELS, HILLARY ANN	DISTRICT WIDE	COORDINATOR-ART	08/06/2025
SALIMBENE, ANN ELIZABETH	BLUE VALLEY NORTH HIGH SCHOOL	12 EXTENDED DAYS-DEPT CHAIR	08/06/2025
SALIMBENE, ANN ELIZABETH	BLUE VALLEY NORTH HIGH SCHOOL	DEPARTMENT CHAIR-SOC SCIENCE	08/06/2025
SAMPLE, JENNIFER D	LAKEWOOD MIDDLE SCHOOL	SUPERVISOR-1/2 HR LUNCHROOM	08/06/2025
SAMPLE, TOBIN JOSEPH	VIRTUAL ED	VIRTUAL EDUCATION-FALL	08/06/2025
SAMUEL, JANELLE MARIE	OVERLAND TRAIL MIDDLE SCHOOL	SUPERVISOR-1/2 HR LUNCHROOM	08/06/2025
SANDERS III, ROBERT LEROY	HARMONY MIDDLE SCHOOL	ASST COACH-BOYS BASKETBALL	11/16/2025
SANDERS III, ROBERT LEROY	HARMONY MIDDLE SCHOOL	SUPERVISOR-1/2 HR LUNCHROOM	08/06/2025
SANDMOEN, SLOANE MILLIKEN	VALLEY PARK ELEMENTARY	ADDL TEACHING CI-YEAR	08/06/2025
SANTEE, MARCY M	LAKEWOOD MIDDLE SCHOOL	LEADERSHIP TEAM MEMBER	08/06/2025
SANTEE, MARCY M	LAKEWOOD MIDDLE SCHOOL	TEAM LEADER-GRADE 6	08/06/2025
SANTIAGO, FRANCISCO JAVIER	DISTRICT WIDE	LIMITED SUPPLY 2 OF 3	09/16/2025
SANTIAGO, NATALIA JULIETA	DISTRICT WIDE	LIMITED SUPPLY 2 OF 3	09/16/2025
SATTLER, TYLER E	BLUE VALLEY MIDDLE SCHOOL	CRD-STUDENT & COMM ENGAGEMENT	08/06/2025
SATTLER, TYLER E	DISTRICT WIDE	LIMITED SUPPLY 3 OF 3	09/16/2025
SATTLER, TYLER E	BLUE VALLEY MIDDLE SCHOOL	SUPERVISOR-1/2 HR LUNCHROOM	08/06/2025
SAULSBERRY, JOHNEA C	DISTRICT WIDE	LEADERSHIP STIPEND-OT	08/06/2025
SAULSBERRY, JOHNEA C	EDUCATIONAL SUPPORT CENTER	MENTOR-NEW TO BV OT	08/06/2025
SCHAAKE, SHARI	BLUE VALLEY SOUTHWEST HS	DEPARTMENT CHAIR-COUNSELOR	08/06/2025
SCHEUFLER, ASHLEY LYNN	DISTRICT WIDE	LIMITED SUPPLY 3 OF 3	09/16/2025
SCHNEEBERGER, CAROL HENDERSON	DISTRICT WIDE	LIMITED SUPPLY 3 OF 3	09/16/2025
SCHULTE, AMY H	BLUE VALLEY NORTH HIGH SCHOOL	ADDL TEACHING PLAN-YEAR	08/06/2025
SCHUTZEL, SUCHUN AMY	WOLF SPRINGS ELEMENTARY	ADDL TEACHING CI-YEAR	08/06/2025
SCOTT, CARRIE SUE	OXFORD MIDDLE SCHOOL	SUPERVISOR-1/2 HR LUNCHROOM	08/06/2025
SECRET, SHAWN KATHLEEN	PLEASANT RIDGE MIDDLE SCHOOL	SUPERVISOR-1/2 HR LUNCHROOM	08/06/2025
SEMANKO, CHARLES JOSEPH	DISTRICT WIDE	LIMITED SUPPLY 2 OF 3	09/16/2025
SERBOUSEK, TIMOTHY LYNN	OXFORD MIDDLE SCHOOL	HEAD COACH-WRESTLING BOYS	11/16/2025
SERBOUSEK, TIMOTHY LYNN	OXFORD MIDDLE SCHOOL	HEAD COACH-WRESTLING GIRLS	11/16/2025



Human Resources Report to the Board of Education

Addendum

October 13, 2025

Administration recommends approval of the following actions:

SETTLE, COLIN CRAIG	BLUE VALLEY SOUTHWEST HS	HEAD COACH-BOYS TENNIS	03/01/2026
SHANNON, NATALIE LYNN	BLUE VALLEY NORTHWEST HS	ASST SPONSOR-CHEERLEADING	08/06/2025
SHANNON, NATALIE LYNN	AUBRY BEND MIDDLE SCHOOL	SUPERVISOR-1/2 HR LUNCHROOM	08/06/2025
SHARP, DAVID CHRISTOPHER	OVERLAND TRAIL MIDDLE SCHOOL	ADMIN CONSULTANT SUPV STIP	08/06/2025
SHARTZER, ABIGAIL MARIE	BLUE VALLEY WEST HIGH SCHOOL	SUPERVISOR-LUNCHROOM	08/06/2025
SHOEMAKER, PAIGE AMANDA	BLUE VALLEY NORTH HIGH SCHOOL	DEPARTMENT CHAIR-FACS	08/06/2025
SHOEMAKER, PAIGE AMANDA	DISTRICT WIDE	FACILITATOR-CURRICULUM TRAININ	08/06/2025
SHOEMAKER, PAIGE AMANDA	BLUE VALLEY NORTH HIGH SCHOOL	HEAD SPONSOR-CHEERLEADING	08/06/2025
SIEPERDA, TAYLOR ELAINE	OVERLAND TRAIL MIDDLE SCHOOL	HEAD COACH-GIRLS TRACK	03/01/2026
SIEPERDA, TAYLOR ELAINE	OVERLAND TRAIL MIDDLE SCHOOL	SUPERVISOR-1/2 HR LUNCHROOM	08/06/2025
SIGNER, JENNIFER L	BLUE VALLEY WEST HIGH SCHOOL	ADDL TEACHING SUPV-YEAR	08/06/2025
SIMER, KATHERINE FRANCES	DISTRICT WIDE	BCBA CERTIFICATION	08/06/2025
SINCLAIR-KING, CRYSTAL L	DISTRICT WIDE	LIMITED SUPPLY 3 OF 3	09/16/2025
SKAKAL, CHELSE RENAE	BLUE VALLEY WEST HIGH SCHOOL	ADDL TEACHING PLAN-YEAR	08/06/2025
SKEENS, WILLIAM ALLEN	CENTER FOR ADV PROF STUDIES	ADDL TEACHING RESPONSIBILITIES	08/06/2025
SKEENS, WILLIAM ALLEN	CENTER FOR ADV PROF STUDIES	CAPS BUSINESS PARTNERSHIP	08/06/2025
SMITH, ANDREA MELI	BLUE VALLEY NORTHWEST HS	8 EXTENDED DAYS-DEPT CHAIR	08/06/2025
SMITH, ANDREA MELI	BLUE VALLEY NORTHWEST HS	DEPARTMENT CHAIR-FOREIGN LNG	08/06/2025
SMITH, BLAISE	DISTRICT WIDE	LIMITED SUPPLY 2 OF 3	09/16/2025
SMITH, JENNIFER REBECCA	DISTRICT WIDE	DIST CRD-STUDENT & COMM ENGMNT	08/06/2025
SMITH, JENNIFER REBECCA	DISTRICT WIDE	NATIONAL BOARD CERTIFICATION	08/06/2025
SMITHYMAN, WILLIAM EDWARD	BLUE VALLEY WEST HIGH SCHOOL	ADDL TEACHING PLAN-YEAR	08/06/2025
SMITHYMAN, WILLIAM EDWARD	DISTRICT WIDE	NATIONAL BOARD CERTIFICATION	08/06/2025
SNODGRASS, REBECCA JO	CENTER FOR ADV PROF STUDIES	ADDL TEACHING RESPONSIBILITIES	08/06/2025
SNODGRASS, REBECCA JO	CENTER FOR ADV PROF STUDIES	CAPS BUSINESS PARTNERSHIP	08/06/2025
SO, HOLLY H	WOLF SPRINGS ELEMENTARY	ADDL TEACHING CI-YEAR	08/06/2025
SOMOGYE, JESSICA C	BLUE VALLEY NORTH HIGH SCHOOL	SPONSOR-LITERARY MAGAZINE	08/06/2025
SOMOGYE, JESSICA C	BLUE VALLEY NORTH HIGH SCHOOL	SPONSOR-NATL CURRIC HONOR SOC	08/06/2025
SPADONI, SHANNON RAE VAIL	DISTRICT WIDE	LIMITED SUPPLY 2 OF 3	09/16/2025
SPIEKER, DAVID ANTHONY	PLEASANT RIDGE MIDDLE SCHOOL	HEAD SPONSOR-SCIENCE OLYMPIAD	09/22/2025
STAINES, RYAN MICHAEL	BLUE VALLEY NORTH HIGH SCHOOL	DIRECTOR-PEP BAND	11/16/2025
STALLBAUMER, KRISTIN ANN	BLUE VALLEY HIGH SCHOOL	COORDINATOR-GRADE LEVEL	08/06/2025
STALLBAUMER, KRISTIN ANN	BLUE VALLEY HIGH SCHOOL	DEPARTMENT CHAIR-COUNSELOR	08/06/2025
STANFIELD, PATRICIA LEE	PLEASANT RIDGE MIDDLE SCHOOL	SUPERVISOR-1/2 HR LUNCHROOM	08/06/2025
STANG, AUSTIN JAMES	BLUE VALLEY NORTH HIGH SCHOOL	ASST DIRECTOR-WINTER MUSICAL	11/16/2025
STANLEY, MICHAEL SCOTT	DISTRICT WIDE	LIMITED SUPPLY 3 OF 3	09/16/2025
STANWAY, SHELBY GRACE	DISTRICT WIDE	LIMITED SUPPLY 2 OF 3	09/16/2025
STEENSON, EMILY MCGEE	DISTRICT WIDE	LIMITED SUPPLY 2 OF 3	09/16/2025
STEGMAN, MACKENZIE E	DISTRICT WIDE	LIMITED SUPPLY 3 OF 3	09/16/2025
STEIN, SHERYL ILENE	BLUE VALLEY NORTH HIGH SCHOOL	12 EXTENDED DAYS-DEPT CHAIR	08/06/2025
STEIN, SHERYL ILENE	BLUE VALLEY NORTH HIGH SCHOOL	DEPARTMENT CHAIR-MATH	08/06/2025
STEVENS, HANNA MICHELLE	HARMONY MIDDLE SCHOOL	ASST DIRECTOR-SPRING MUSICAL	11/16/2025
STEVENS, HANNAH J	BLUE VALLEY ACADEMY	SUPERVISOR-LUNCHROOM	08/06/2025
STEWART, KASEY MARIE	DISTRICT WIDE	LIMITED SUPPLY 2 OF 3	09/16/2025



Human Resources Report to the Board of Education

Addendum

October 13, 2025

Administration recommends approval of the following actions:

STEWART, OLIVIA ROSE	DISTRICT WIDE	LIMITED SUPPLY 2 OF 3	09/16/2025
STEWART, TAYLOR KYLE	AUBRY BEND MIDDLE SCHOOL	SUPERVISOR-1/2 HR LUNCHROOM	08/06/2025
STOUT, SHAWNA LEIGH	BLUE VALLEY MIDDLE SCHOOL	SUPERVISOR-1/2 HR LUNCHROOM	08/06/2025
STRAWDER, CRYSTAL JOY	DISTRICT WIDE	LIMITED SUPPLY 1 OF 3	09/16/2025
STRAWDER, CRYSTAL JOY	BLUE VALLEY SOUTHWEST HS	TECHNOLOGY STIPEND	08/06/2025
SUHR, KEVIN RAYMOND	BLUE VALLEY MIDDLE SCHOOL	ASST COACH-BOYS BASKETBALL	11/16/2025
SUHR, KEVIN RAYMOND	BLUE VALLEY MIDDLE SCHOOL	SUPERVISOR-1/2 HR LUNCHROOM	08/06/2025
SUHR, SARAH CATHERINE	DISTRICT WIDE	LIMITED SUPPLY 3 OF 3	09/16/2025
SULLIVAN, ATHENA VENEICE	DISTRICT WIDE	NATIONAL BOARD CERTIFICATION	08/06/2025
SUMMERLIN, VICTORIA MARGARET	DISTRICT WIDE	LIMITED SUPPLY 2 OF 3	09/16/2025
SUN, GUONA	VALLEY PARK ELEMENTARY	ADDL TEACHING CI-YEAR	08/06/2025
SUTCLIFFE, TREVOR L	CENTER FOR ADV PROF STUDIES	ADDL TEACHING RESPONSIBILITIES	08/06/2025
SUTCLIFFE, TREVOR L	CENTER FOR ADV PROF STUDIES	CAPS BUSINESS PARTNERSHIP	08/06/2025
SVATOS, DOMINIC JOSEPH	DISTRICT WIDE	LIMITED SUPPLY 3 OF 3	09/16/2025
SWANSON, PATRICK	BLUE VALLEY NORTHWEST HS	ADDL TEACHING PLAN-2ND SEM	01/05/2026
SWARTZ, MIRANDA E	PLEASANT RIDGE MIDDLE SCHOOL	SPONSOR-DIVERSITY CLUB	08/06/2025
TALLEY, SARA FELICITY	DISTRICT WIDE	COORDINATOR-COUNSELING	08/06/2025
TAYLOR, KENNETH DALE	BLUE VALLEY NORTH HIGH SCHOOL	ADDL TEACHING PLAN-YEAR	08/06/2025
TAYLOR, KENNETH DALE	BLUE VALLEY NORTH HIGH SCHOOL	DEPARTMENT CHAIR-COMM ARTS	08/06/2025
TAYLOR, LAURA KATHERINE	BLUE VALLEY WEST HIGH SCHOOL	DEPARTMENT CHAIR-COUNSELOR	08/06/2025
TAYLOR, MARTHA L	DISTRICT WIDE	LIMITED SUPPLY 2 OF 3	09/16/2025
THOMPSON, BRITTON TANNER	BLUE VALLEY MIDDLE SCHOOL	SUPERVISOR-1/2 HR LUNCHROOM	08/06/2025
THOMPSON, DEREK ALLEN	DISTRICT WIDE	DRUG & ALCOHOL COORDINATOR	09/01/2025
THOMPSON, DEREK ALLEN	DISTRICT WIDE	LIMITED SUPPLY 3 OF 3	09/16/2025
THOMPSON, KIMBERLY BRIANNE	BLUE VALLEY HIGH SCHOOL	COORDINATOR-BUILDING ADVISORY	08/06/2025
THURSTON, TRAVIS LLOYD	BLUE VALLEY WEST HIGH SCHOOL	ADDL TEACHING PLAN-YEAR	08/06/2025
TIFFANY, SCOTT CHANDLER	AUBRY BEND MIDDLE SCHOOL	SUPERVISOR-1/2 HR LUNCHROOM	08/06/2025
TODD, AMANDA WREN	BLUE VALLEY SOUTHWEST HS	DEPARTMENT CHAIR-SPED	08/06/2025
TODD, AMANDA WREN	EDUCATIONAL SUPPORT CENTER	DIGITAL ASSESSMENT RESOURCES	08/06/2025
TODD, AMANDA WREN	DISTRICT WIDE	LEADERSHIP STIPEND-PSYCH	08/06/2025
TODD, JEREMY	CENTER FOR ADV PROF STUDIES	ADDL TEACHING RESPONSIBILITIES	08/06/2025
TODD, JEREMY	CENTER FOR ADV PROF STUDIES	CAPS BUSINESS PARTNERSHIP	08/06/2025
TOEPFER, ASHTYN LYNN	LEAWOOD MIDDLE SCHOOL	LEADERSHIP TEAM MEMBER	08/06/2025
TRADER, MEGHAN S	BLUE VALLEY NORTHWEST HS	10 EXTENDED DAYS-DEPT CHAIR	08/06/2025
TRADER, MEGHAN S	BLUE VALLEY NORTHWEST HS	DEPARTMENT CHAIR-CTE	08/06/2025
TRIMBLE, MEGAN M	OXFORD MIDDLE SCHOOL	SUPERVISOR-1/2 HR LUNCHROOM	08/06/2025
TUEL, KELLEY ROCHELLE	CENTER FOR ADV PROF STUDIES	CAPS BUSINESS PARTNERSHIP	08/06/2025
TYNDALL, BETHANY RUTH	DISTRICT WIDE	LIMITED SUPPLY 2 OF 3	09/16/2025
TYSHLEK, EMMA ROSE	DISTRICT WIDE	LIMITED SUPPLY 1 OF 3	09/16/2025
VAN LEEUWEN, KALE H	OVERLAND TRAIL ELEMENTARY	DIRECTOR-CHOIR	08/06/2025
VAN SCOYOC, ELIZABETH ABBOTT	DISTRICT WIDE	LIMITED SUPPLY 3 OF 3	09/16/2025
VODEHNAL, JULIE ANN	DISTRICT WIDE	NATIONAL BOARD CERTIFICATION	08/06/2025
VODEHNAL, JULIE ANN	DISTRICT WIDE	PDC REPRESENTATIVE	08/06/2025
VODEHNAL, MICHAEL PAUL	BLUE VALLEY NORTHWEST HS	ADDL TEACHING PLAN-YEAR	08/06/2025



Human Resources Report to the Board of Education

Addendum

October 13, 2025

Administration recommends approval of the following actions:

VOKAC, BETHANY JANE	DISTRICT WIDE	NATIONAL BOARD CERTIFICATION	08/06/2025
VORNDRAN, DORIS IRENE	DISTRICT WIDE	LIMITED SUPPLY 3 OF 3	09/16/2025
VU, LUKE MINH DANG	BLUE VALLEY NORTHWEST HS	ASST COACH-DEBATE	09/11/2025
WADE, JENNIFER LYN	PRAIRIE STAR MIDDLE SCHOOL	SUPERVISOR-1/2 HR LUNCHROOM	08/06/2025
WAGONER, JOEL DAVID	OVERLAND TRAIL MIDDLE SCHOOL	SUPERVISOR-1/2 HR LUNCHROOM	08/06/2025
WALKER, AUBRIE NORINE	DISTRICT WIDE	BCBA CERTIFICATION	08/06/2025
WALLACE, OLIVIA LITTLEWOOD	BLUE VALLEY WEST HIGH SCHOOL	ADDL TEACHING PLAN-1ST SEM	08/06/2025
WALLACE, OLIVIA LITTLEWOOD	BLUE VALLEY WEST HIGH SCHOOL	SUPERVISOR-LUNCHROOM	08/06/2025
WARNES, TIFFANY NICOLE	BLUE VALLEY WEST HIGH SCHOOL	SUPERVISOR-LUNCHROOM	08/06/2025
WARRICK, MANDI LYNN	LEAWOOD MIDDLE SCHOOL	SUPERVISOR-1/2 HR LUNCHROOM	08/06/2025
WASINGER, RICK W	BLUE VALLEY NORTH HIGH SCHOOL	SUPERVISOR-GYMNASIUM	11/16/2025
WATSON, CASEY JOHN	OVERLAND TRAIL MIDDLE SCHOOL	SUPERVISOR-1/2 HR LUNCHROOM	08/06/2025
WATTS, RACHEL LUCILLE	DISTRICT WIDE	LIMITED SUPPLY 3 OF 3	09/16/2025
WEDEMEIER, SHANNON COLLEEN	DISTRICT WIDE	LIMITED SUPPLY 2 OF 3	09/16/2025
WELLS, MARY MELINDA	DISTRICT WIDE	DRUG & ALCOHOL COORDINATOR	09/01/2025
WELLS, MARY MELINDA	DISTRICT WIDE	LEADERSHIP STIPEND-FLIGHT TEAM	08/06/2025
WHALEN, JOSEPH PATRICK	CENTER FOR ADV PROF STUDIES	ADDL TEACHING RESPONSIBILITIES	08/06/2025
WHALEN, JOSEPH PATRICK	CENTER FOR ADV PROF STUDIES	CAPS BUSINESS PARTNERSHIP	08/06/2025
WHETZEL, AARON EDWARD	VIRTUAL ED	VIRTUAL EDUCATION-FALL	08/06/2025
WHITE, JOEL THOMAS	BLUE VALLEY SOUTHWEST HS	ADDL TEACHING PLAN-YEAR	08/06/2025
WIENS, NATHAN P	DISTRICT WIDE	NATIONAL BOARD CERTIFICATION	08/06/2025
WILCOX, BROOKE E	DISTRICT WIDE	LIMITED SUPPLY 3 OF 3	09/16/2025
WILES, ALLISON RAE	EDUCATIONAL SUPPORT CENTER	ADDL TEACHING RESPONSIBILITIES	08/06/2025
WILLIAMS, AARON TYLER	HARMONY MIDDLE SCHOOL	ASST COACH-TRACK	03/01/2026
WILLIAMS, SAVANNAH BAILEY	BLUE VALLEY HIGH SCHOOL	ADDL TEACHING SUPV-1ST SEM	09/29/2025
WILLIAMS, SAVANNAH BAILEY	DISTRICT WIDE	LIMITED SUPPLY 3 OF 3	09/16/2025
WILLIAMSON, ROBERT TYLER	DISTRICT WIDE	LIMITED SUPPLY 3 OF 3	09/16/2025
WILLSON, ALLISON LEE	AUBRY BEND MIDDLE SCHOOL	SUPERVISOR-1/2 HR LUNCHROOM	08/06/2025
WINGATE, EMERSON VENESSA	WOLF SPRINGS ELEMENTARY	ADDL TEACHING CI-YEAR	08/06/2025
WINTERS, EMILY ASPEN	BLUE VALLEY SOUTHWEST HS	COORDINATOR-GRADE LEVEL	08/06/2025
WINTON, JULIAN SHAWON	BLUE VALLEY NORTHWEST HS	ASST COACH-BOYS BASKETBALL	11/16/2025
WISEMAN, NICOLE ELIZABETH	DISTRICT WIDE	LIMITED SUPPLY 3 OF 3	09/16/2025
WISEMAN, TIM JEROME	BLUE VALLEY MIDDLE SCHOOL	SUPERVISOR-1/2 HR LUNCHROOM	08/06/2025
WOFFORD, C'AWNA CARLISA	BLUE VALLEY SOUTHWEST HS	SUPERVISOR-LUNCHROOM	08/06/2025
WOLTERS, CARLA JEAN	DISTRICT WIDE	LIMITED SUPPLY 3 OF 3	09/16/2025
WORTHINGTON, MARIA ANNE	DISTRICT WIDE	NATIONAL BOARD CERTIFICATION	08/06/2025
WOULFE, JULIE MARIE	BLUE VALLEY MIDDLE SCHOOL	SUPERVISOR-1/2 HR LUNCHROOM	08/06/2025
WRAY, BENJAMIN TIPTON	DISTRICT WIDE	NATIONAL BOARD CERTIFICATION	08/06/2025
WRIGHT, JEFFREY DONALD	AUBRY BEND MIDDLE SCHOOL	SUPERVISOR-1/2 HR LUNCHROOM	08/06/2025
YARNELL, JEFF E	BLUE VALLEY HIGH SCHOOL	DEPARTMENT CHAIR-PERFORM ARTS	08/06/2025
YOUNG, AMY S	DISTRICT WIDE	NATIONAL BOARD CERTIFICATION	08/06/2025
YOUNG, AMY S	PRAIRIE STAR MIDDLE SCHOOL	SUPERVISOR-1/2 HR LUNCHROOM	08/06/2025
YOUNG, DENISE LYNN	BLUE VALLEY WEST HIGH SCHOOL	ADDL TEACHING PLAN-YEAR	08/06/2025
ZAGORSKI, MOLLY ELIZABETH	LAKWOOD MIDDLE SCHOOL	SUPERVISOR-1/2 HR LUNCHROOM	08/06/2025



Human Resources Report to the Board of Education

Addendum

October 13, 2025

Administration recommends approval of the following actions:

ZHANG, HANXUAN
ZHANG, HU
ZIEGLER, KRISTIE M

DISTRICT WIDE
OVERLAND TRAIL MIDDLE SCHOOL
DISTRICT WIDE

LIMITED SUPPLY 2 OF 2
HEAD SPONSOR-SCIENCE OLYMPIAD
LIMITED SUPPLY 3 OF 3

09/16/2025
09/15/2025
09/16/2025



Human Resources Report to the Board of Education

October 13, 2025

Administration recommends approval of the following actions:

APPOINTMENTS

<u>Name</u>	<u>Location</u>	<u>Position</u>	<u>Effective</u>
BAILEY, MEGAN ELIZABETH	COTTONWOOD POINT ELEMENTARY	SPEECH LANGUAGE PATHOLOGIST	10/13/2025
BAILEY, MEGAN ELIZABETH	HEARTLAND ELEMENTARY	SPEECH LANGUAGE PATHOLOGIST	10/13/2025
BECKWITH, STEPHANIE JOY	HARMONY ELEMENTARY	SPEECH LANGUAGE PATHOLOGIST	01/05/2026
LAUNIUS, RACHEL CHRISTINE	BLUE VALLEY WEST HIGH SCHOOL	SPED TEACHER-INTENSIVE RESC	10/16/2025
PARKER BUCCI, RILEY	LEAWOOD ELEMENTARY	TEACHER-SPANISH	08/03/2026



Human Resources Report to the Board of Education

October 13, 2025

Administration recommends approval of the following actions:

RESIGNATIONS

<u>Name</u>	<u>Location</u>	<u>Position</u>	<u>Effective</u>
MORRIS, JESSICA ELIZABETH	HARMONY ELEMENTARY	SPEECH LANGUAGE PATHOLOGIST	09/26/2025
RICCARDI, KELLEY SUZANNE	BLUE VALLEY HIGH SCHOOL	SCHOOL NURSE	09/26/2025
WOODS, BRYAN DAVID	VALLEY PARK ELEMENTARY	SPED TEACHER-INTENSIVE RESC	09/25/2025



Human Resources Report to the Board of Education

October 13, 2025

Administration recommends approval of the following actions:

RETIREMENTS

<u>Name</u>	<u>Location</u>	<u>Position</u>	<u>Effective</u>
JILKA, THERESE MARIE	PLEASANT RIDGE MIDDLE SCHOOL	TEACHER-GRADE 8	05/22/2026



Human Resources Report to the Board of Education

Addendum

October 13, 2025

TERMINATION

<u>Name</u>	<u>Location</u>	<u>Position</u>	<u>Reason</u>
Hart, Barbara	SRE	Teacher	BOE Policy 3522 Violation